

Martyr®
The world's premium marine anode

CATALOG

Al premium
SALT AND BRACKISH WATER

Mg fresh
FRESH WATER ONLY

Zn traditional
SALT WATER ONLY



PROTECT YOUR BOAT, RESPECT OUR WATERS

CATHODIC PROTECTION FOR PLEASURECRAFT BOATS,
SAIL BOATS, BOAT ACCESSORIES, OUTBOARDS & OUTDRIVES,
COMMERCIAL VESSELS, PIERS, OFF-SHORE DRILLING PLATFORMS,
DRYDOCKS, RETAINING WALLS & OCEANOGRAPHIC EQUIPMENT

CMP

CMP Group Ltd.

sales@canmet.com | cmpgroup.net



Martyr

A N O D E S

ABOUT US

CMP is the world's leading manufacturer and supplier of die cast Aluminum, Magnesium and Zinc anodes, which are sold worldwide under the Martyr® brand name.

The company first began foundry operations during the early 1900's servicing the plumbing and forestry industries. Their non-ferrous capabilities allowed the company to expand its product offering. This included manufacturing of gravity cast Aluminum and Zinc anodes for the commercial marine industry. The innovative development of new alloys and casting techniques enabled the company to gain an international reputation of superior quality for its Martyr® brand of sacrificial marine anodes.

Building on the success achieved in the commercial marine market the company was able to offer the utility of their performance enhanced alloys to the world's leading marine engine builders. Here the company was able to use the process of pressure diecasting to produce more intricate castings that were needed by the fast growing pleasurecraft industry.

Today CMP is in a state of continuous improvement. Our people and our commitment to quality is the foundation in which we will perpetuate our growth and prosperity.

Thank you for your support!

Team CMP

t. 1-604-940-2010 / f. 1-604-952-2650
sales@martyranodes.com
www.martyranodes.com

TABLE OF CONTENTS:

HOW TO USE THIS CATALOG	3	MTF™ ANODES	52	RENAULT™ ANODES	111
WHAT IS CORROSION?	5	RADICE™ ANODES	52	SELVA™ ANODES	112
ALUMINUM QUICK FACTS	8	REGGIANI™ ANODES	57	SUZUKI™ ANODES	113
WHY CADMIUM FREE ANODES?	9	RIVA™ ANODES	58	VOLVO PENTA™ ANODES	116
PID INDEX (CHRONOLOGICAL)	12	INTERNAL SQUARE ANODES	58	YAMAHA™ ANODES	126
PID INDEX (ALPANUMERIC)	201	SHAFRAN™ ANODES	59	MISCELLANEOUS ANODES	
MARKETING TOOLS	10	SOLE™ ANODES	59	BENNETT™ ANODES	141
FIND US ON THE WEB	11	PROP NUT & BOW THRUSTER		DE-ICER ANODES	141
MIL-SPECS	20	LEWMAR™ ANODES	61	FRIGO-BOAT™ ANODES	141
NEW PRODUCTS	21	MAX POWER™ ANODES	61	GROUND PLATES	141
ANODE LOCATION CHARTS	154	HULL ANODES		LINE CUTTER	142
CMP PROFILE	207	GROUPEUR	63	SEA STRAINER™ ANODES	142
ISO CERTIFICATE	153	BONDING KIT	64	TWIN DISC™ ANODES	143
PLEASURECRAFT ANODES:		DIVER'S DREAM	64	ENGINE COOLING SYSTEM ANODES	144
SHAFT & RUDDER ANODES		PLEASURECRAFT HULL ANODES	66	COMMERCIAL ANODES:	
STREAMLINED SHAFT ANODES	31	RP SERIES ROUND PLATE ANODES	74	HULL ANODES	157
CLAMP SHAFT ANODES	35	ROUND PLATE ANODES	75	BALLAST TANK	173
LIMITED CLEARANCE SHAFT ANODES	37	INBOARD/OUTBOARD/ STERNDRIVE ANODES		CABLE	173
EURO STYLE SHAFT ANODES	39	BRP™ (OMC/JOHNSON EVINRUDE)	77	CONDENSER ANODES	173
RUDDER/TRIM TAB ANODES	40	BMW™ ANODES	85	CRAB TRAP	174
SPANISH STYLE RUDDER/TRIM TAB 41		BUKH™ ANODES	86	HEATER EXCHANGER ANODES	174
PROPELLER ANODES		CASTOLDI™ ANODES	86	OLYMPIC DRIVE	175
PROPELLER NUT ANODES	43	HIDEA™ ANODES	86	PLATFORM/STANDOFF	175
AUTOPROP™ ANODES	44	HONDA™ ANODES	87	HEATER TREATER	175
BENETEAU™ ANODES	45	KAMEWA™ ANODES	90	PROP NUT ANODES	175
FERRETTI™ ANODES	47	LOMBARDINI™ ANODES	91	PLATE STOCK ANODES	176
FLEXOFOLD™ ANODES	48	MERCURY™/MERCUISER	92	ROD STOCK ANODES	188
GORI™ ANODES	49	NISSAN / TOHATSU™ ANODES	106	FERNSTRUM KEEL	179
J-PROP™ ANODES	50	PAINIER™ ANODES	108	WALTER KEEL	179
MAX PROP™ ANODES	50	PARSUN™ ANODES	109	SPECIAL ORDERS	181

Our team is composed of conscientious individuals who are:

Dedicated to timely delivery of defect free products;

—

Committed to continuous process improvement;

—

Diligent in their efforts to protect the environment.



.....
The descriptions and guidelines shown in this literature should be used as a general reference only. For any further technical information please contact our Technical Service Team. Contents of this Brochure/Catalog are based on the latest information available at the time of publication.

CMP / Martyr® assumes no responsibility for the accuracy of the information contained herein. Product specifications are subject to change without notice.
.....

HOW TO USE THIS CATALOG

We have made it easy to help you find the right anode for the job! Throughout this product catalog you will notice three distinct colors each representing a specific alloy type. Each alloy we offer is specially formulated to work the best when used in the right water environment. To order, simply find the right engine or anode type then look for a green, blue or yellow mark. Add the letters A, M, or Z to the product code.

For example:

CM31640A = ALUMINUM Alloy • CM31640M = MAGNESIUM Alloy • CM31640Z = ZINC Alloy



ALUMINUM PREMIUM – For use in salt and brackish water. Performs better, protects longer than Zinc. Alloy is manufactured to meet or exceed US Military Specification (MIL-DTL-24779C(SH)).



MAGNESIUM FRESH – ONLY for use in fresh water. Not recommended for use in salt or brackish water. The only alloy proven to protect your boat in fresh water. Alloy is manufactured to meet or exceed US Military Specification (AZ91D).



ZINC TRADITIONAL – For use in salt water. Not recommended for use in fresh water. Alloy is manufactured to meet or exceed US Military Specification (MIL-DTL-18001L).

Don't be fooled by claims that only one alloy will protect in all water environments. Only MARTYR® Anodes offers you the choice of the right protection for any application!

Drawing Legends:

L	W	H	D	OD	ID	T	THD
Length	Width	Height	Distance	Outside Diameter	Inside Diameter	Thickness	Thread

*All trademarks remain property of their respective holders, and are used only to directly describe the products being provided.

"YAMAHA" is a registered trademark of Yamaha Corporation • "Radice" is a registered trademark of Eliche Radice SPA • "AUTOPROP" is a registered trademark of Bruntons Propellers • "Beneteau" is a registered trademark of Beneteau USA Boats • "ARNESON" is a registered trademark of Arneson Industries • "MAX PROP" is a registered trademark of PYI Inc. • "Bennett Trim Tab" is a registered trademark of Bennett Trim Tabs • "Tohatsu" is a registered trademark of Tohatsu Outboards • "BOMBARDIER" and the BOMBARDIER & Sprocket Design are both trademarks of BOMBARDIER Inc. • "JOHNSON", "EVINRUDE" and other marks presented, and their associated graphic designs, are trademarks of BOMBARDIER RECREATIONAL PRODUCTS INC. "ROTAX" and its associated graphic designs are trademarks of BRP-ROTAX GMBH & CO. KG. • "LYNX" and its associated graphic designs are trademarks of BRP-FINLAND OY. • "FLEXOFOLD" is a registered trademark of Flexofold Sailboat Propellers • "BUKH" is a registered trademark of BUKH Diesel UK • The trademark "Honda" and any other product names, service names or logos of Honda used, quoted and/or referenced in this catalog are trademarks or registered trademarks of Honda or any of its affiliates. • "Solé Diesel" is a registered trademark of Sole, S.A. • Trademarks, logos, and service marks displayed are registered and unregistered trademarks of "Mercury", "Mercuriser" and "Verado", its affiliates, its licensors, its content providers, and other third parties. All of these trademarks, logos, and service marks are the property of their respective owners • "NISSAN MARINE" is a registered trademark of Nissan Marine • "VOLVO" is a registered trademark of Volvo Penta • "SUZUKI" is a registered trademark of Suzuki Motor Corporation • "FRIGO-BOAT" is a registered trademark of Frigo Boat Marine Refrigeration • "Walter Keel" is a registered trademark of Walter Keel Coolers • "YANMAR" is a registered trademark of YANMAR America Corporation. "OLYMPIC" is a registered trademark of Olympic Drives & Equipment Ltd.

Other product names and/or company names used in the catalog may be protected as their trademarks and/or trade names.



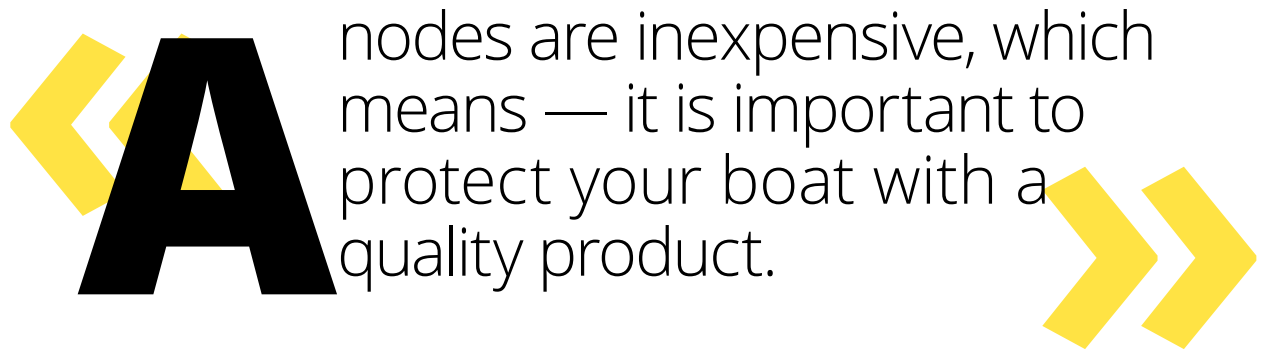

Anodes are inexpensive, which means — it is important to protect your boat with a quality product.

WHY USE MARTYR® ANODES?

Anodes are inexpensive, which means it is important to protect your boat with a quality product. Martyr® Anodes are pressure die cast and manufactured to strict quality standards through an ISO 9001 Quality Management System. Every anode is UPC barcoded. In addition, each alloy is guaranteed to be manufactured to the latest US Military Alloy Specification and is chemically tested regularly in our in-house labs to ensure consistency.

Poorly manufactured anodes may contain high levels of impurities such as iron, which will leave your boat unprotected. Martyr® Anodes manufactures all three alloys for the three main water environments. Not all anodes are created equal so to be sure buy genuine Martyr® Anodes.

CORROSION WILL OCCUR IN ALL TYPES OF WATER WITH DRAMATIC EFFECT

Metals have different electrochemical potentials when in contact with one another and form Galvanic cells. The metal with a lower potential in the galvanic cell will be anodic and will corrode. The same effect can occur in areas of different electrochemical potential in a single piece of metal such as a steel plate. Any craft moored and operating in fresh, salt or brackish water is at risk from corrosion and

the effects can be costly. Corrosion on Steel & Aluminum vessels can be identified as either areas of localized pitting to the hull plate, rudders, bilge keels etc. or less obviously in the form of general wastage of the hull plating often occurring below the paint coating. Pitting can lead to the complete penetration of the hull below the waterline. General wastage of the steel can be just as critical, weakening the hull and necessitating expensive replating.

On wood and GRP vessels the areas of concern are principally the stern gear i.e. the propellers, shafts, shaft brackets, stern tubes and rudders which are expensive to replace and vital to the vessel, the failure of a propeller or rudder could have disastrous consequences. The effects of corrosion can vary from pitting of propellers and shafts to the decomposition of the alloy of propeller. The failure of something as small and inexpensive as a split pin can result in the loss of the propeller.

Stray current leakage is quite often cited as the cause of corrosion on all types of vessels, however, more often than not the problem can be traced to a galvanic action. Stray current leakage is the action of electrical current from an external power source such as a battery or shore power supply which because of some

electrical system fault on board the vessel passes out through the hull or a fitting in the hull and flows through the water causing "Electrolytic" corrosion. Stray current leakage is usually a result of damage or wear to the wiring system or poor installation of wiring or electrical equipment.

WHAT CAN BE DONE TO PREVENT CORROSION?

The selection of materials is of prime importance in the construction of craft. Generally naval architects and boat builders ensure that they select metals which are as far as possible compatible to each other and when this is not possible metals must be isolated from one another.

There will always be occasions when fittings or steelwork require replacement or repair and it is important that when this is done attention is paid to the same criteria. In particular, ensure that fastenings and split pins are compatible and of the highest quality.

The paint system on any boat is an important first barrier against corrosion. Seek advice from the paint manufacturers for their recommendations on the most appropriate coating system and follow the application instructions completely. Ensure that a good anti-corrosive primer is applied if anti-fouling is to be used. When using a copper based anti-fouling none of the paint must be applied directly to bare metal surfaces.

Vegetable oil based paints, although far less widely available than in the past, should not be used with cathodic protection systems as the paint tends to saponify. The correct installation of electrics on a boat will reduce the possibility of stray current leakage and the following actions are recommended.

- Use only high grade insulated wiring of suitable capacity. Undersized wires will cause resistance and consequent voltage drop.
- Clip or support all wires at suitable intervals to prevent fatigue and eventual fracture.
- Use only corrosion resistant terminals and connectors and make sure that all are clean and tight.
- Attach only the main battery leads to battery terminals.
- Fit an isolation switch in the battery circuit.
- Ensure that all battery circuits are correctly fused.
- Keep all wiring, connections and junction boxes above the bilge area and other areas likely to become wet.



Make sure that when fitting additional equipment the work is carried out in accordance with the manufacturer's instructions. The polarity of connections should be correct and each circuit must be correctly fused. Electrical and electronic work is best carried out by a qualified marine electrician.

Ongoing maintenance on your boat is essential. Metal work, paint coatings and electrical installations all require regular inspection. In particular, you should inspect the wind and water line area if owning a steel vessel. This area is particularly vulnerable because it is often prone to mechanical damage but derives no protection from an anode system being above the water line.

WHAT IS CATHODIC PROTECTION?

Cathodic protection is an electrochemical process which halts the natural reaction (corrosion) of metals in a particular environment by superimposing an electrochemical cell more powerful than the corrosion cell.

Sacrificial Anodes are fitted or bonded to the metal to be protected which in turn as it has a greater electrical potential than the anode material becomes cathodic and causes the anode to waste instead of itself. In a correctly installed Martyr® Cathodic Protection System the only corrosion occurs to the sacrificial anode which is replaceable. The number and size of anodes is determined by the type of material and the surface area being protected.

The term bonding refers to the connection of the anode to a remote metal component such as the propeller shaft of rudder stock and it should be remembered that the integrity of the bonding is critical to the effectiveness of the cathodic protection system.

Several factors determine the type of cathodic protection system fitted. Firstly, the environment in which the vessel is operating, secondly, the size and type of construction and, finally, the length of time that the vessel is likely to be afloat before the next maintenance slipping.

FIT THE CORRECT ANODE MATERIAL FOR THE WATERS YOUR VESSEL OPERATES IN

As a general rule owners should fit the anodes suitable for the environment they most regularly berth in and the following table provides a useful guide:

- **Salt Water:** Fit Aluminum (Premium) or Zinc (Traditional) Anodes
- **Brackish Water:** Fit Aluminum (Premium) Anodes
- **Fresh Water:** Fit Magnesium (Fresh) anodes

Some vessels will from time to time move between salt and fresh water, others are berthed within marinas and behind tidal barriers where the water is enclosed and likely to be brackish

or even virtually fresh. Owners must be aware of the effects that this may have on their boats and fit the correct cathodic protection system to avoid corrosion.

Not all anodes are suitable for every environment, for example the surface of a zinc or Aluminum anode will, if left in fresh water for some time, become covered with an off-white crust of oxide which effectively seals the anode and stops it working even when returned to salt water.

Zinc Anodes suffer a similar problem even in brackish conditions whereas Aluminum will continue to operate effectively in river estuaries and other areas of brackish water indefinitely. The consequences of this passivity of the anode are that the next most anodic item within the anode bonding system will start to sacrifice itself which could of course be very serious.

It is therefore very important to check Zinc and Aluminum anodes after any trips into fresh water and if necessary clean off or change the anodes. Should a vessel move into fresh water for more than two weeks Martyr® recommends that an alternative

anode system is used suitable for fresh water situations.

Magnesium Anodes on the other hand have a much higher driving voltage than Zinc or Aluminum making them highly suitable for use in fresh water, they will, however, become very active in salt water where they will probably only last a matter of months. Protected surfaces can build up a layer of off-white calcareous deposit which will be difficult to remove. Magnesium anodes are not designed for prolonged use in sea water and if you are taking your boat into a salt water location for more than seven days (fourteen days in any one year) you should consider changing the anodes.

■ Reprinted courtesy of **Mg Duff Int.**





MARTYR® PREMIUM ALUMINUM ANODES:

- Perform **at least 5% better** than Traditional Zinc anodes in saltwater;
- Protect **50% longer** than Traditional Zinc anodes;
- Are environmentally friendly — contain **0% Cadmium**, a toxic material found in Traditional Zinc anodes;
- Weigh **50% less** than Traditional Zinc anodes;
- Meet the US Military Specification **Mil-DTL-24779C(SH)**;
- Are the only anodes proven to be effective in **Salt & Brackish water**;
- Results in considerable cost savings compared with Traditional Zinc anodes on commercial products.



WHY ZINC-LESS?

1. EPA recommended Cathodic protection for sacrificial anode systems – choose the least toxic material that is practical. In order of preference: magnesium, aluminum, then zinc. ■ **ECM Maritime Services**

2. The MTABC Board recommended that zinc anodes be prohibited now that Aluminum anodes are available for virtually every application. It is the position of the MTABC Board that this legislation will truly and effectively reduce copper and zinc levels entering the Bay. The availability of copper-free paints and aluminum anodes has been satisfactorily explored. ■ **Marine Trades Association of Baltimore Country**

3. Connecticut Department of Environmental Protection recommended Zinc Replacement: Potential Environmental Impacts – Sacrificial zinc anodes fight corrosion in salt water by deterring corrosion of metal hull and engine parts. Elevated levels of zinc in marina sediments have been found to be associated with boat operation and maintenance. Zinc, in high concentrations, can be toxic to marine life, and can be potentially toxic to humans who eat contaminated shellfish or fish. ■ **Connecticut Clean Marina Guidebook 2007, Pg. 26**

4. BoatTECH advised in April 2012: In recent years cadmium in zinc has become an environmental concern, leading to a movement in the direction of aluminum anodes. Such anodes are effective even for protecting aluminum components – lower end cases, for example – because the aluminum used in the anode is a more anodic alloy. Aluminum alloy anodes are almost certainly to become more common. It has not happened already only because the cost of aluminum anodes has been higher than zinc without any discernable benefit to the boat owner. Today aluminum is actually cheaper than zinc. In addition, aluminum anodes tend to last longer, they work better than zinc in brackish water (and maybe in salt water as well) and they appear to be better for the environment.

When making the switch from zinc to aluminum, ALL of your anodes must be aluminum. This can be a problem in some locales as many local marine suppliers still do not stock a wide selection of aluminum anodes. That will eventually change. In fresh water, magnesium anodes protect underwater metals better, particularly underwater aluminum. However, magnesium is a good choice for freshwater only. If any of your boating is also in brackish or salt water, fit aluminum anodes. ■ <http://www.boatus.com/boattech/casey/sacrificial-zincs.asp> by Don Casey

MARKETING TOOLS

We can provide a range of marketing materials to help promote our products.

Please email us with PID# at marketing@canmet.com or order via our website:

martyranodes.com

PID	DESCRIPTION
CMALUFACFLY	Aluminum Facts flyer (single page)
CMALUINFOFLY	Aluminum Facts flyer (double-sided)
CMANOLOCPOS	Martyr® "Anode location" poster
CM3ALLCARD	Martyr® 3-alloy card
03SLS00030	Martyr® removable window sticker
03SLS00106	Martyr® Plan-O-Gram brochure



CMANOLOCPOS



CMALUFACFLY



CMALUINFOFLY



03SLS00106



03SLS00030



CM3ALLCARD

FIND AND FOLLOW US ON THE WEB!



Scan this with your mobile device for Martyr® website:
<http://martyranodes.com/>



Scan this with your mobile device for Martyr® facebook:
<https://www.facebook.com/MartyrAnodes>



Scan this with your mobile device for Martyr® twitter:
<https://twitter.com/martyranodes>



Scan this with your mobile device for Martyr® youtube channel:
<https://www.youtube.com/user/MartyrAnodes>



Scan this with your mobile device for Martyr® Instagram!
<https://www.instagram.com/martyranodes/>



Scan this with your mobile device for CMP Group linkedin page:
<https://www.linkedin.com/company/cmpgrouppltd/>

PID INDEX (CHRONOLOGICAL)

PLEASURECRAFT SHAFT / RUDDER	29	CMX13HDZ/A/M	35	CMC100/A/M	39
STREAMLINED SHAFT / IMPERIAL	31	CMX16HDZ/A/M	35	CMC120/A/M	39
CMX00/A/M	31	CMX17HDZ/A/M	35	EU STYLE CLEARANCE SHAFT	39
CMX01/AL/M	31	CMX1L7HDZ/A/M	35	CMC22EURO/A/M	39
CMX018125/AL	31	CMX18HDZ/A/M	35	CMC25EURO/A/M	39
CMX02/AL/M	31	CLAMP SHAFT / IMPERIAL	35	CMC30EURO/A/M	39
CMX03/AL/M	31	CMXC01Z/A/M	35	CMC35EURO/A/M	39
CMX04/AL/M	31	CMXC02Z/A/M	35	CMC40EURO/A/M	39
CMX05/AL/M	31	CMXC03Z/A/M	35	CMC45EURO/A/M	39
CMX05A/AL/M	31	CMXC04Z/A/M	35	CMC50EURO/A/M	39
CMX0625	31	CMXC05Z/A/M	35	RUDDER / TRIM TAB	40
CMX07/AL/M	31	CMXC06Z/A/M	36	CMR01/AL/M	40
CMX08/AL/M	31	CMXC07Z/A/M	36	CMR02/AL/M	40
CMX09/AL/M	31	CMXC08Z/A/M	36	CMR03/AL/M	40
CMX10/AL/M	32	CMXC09Z/A/M	36	CMR04/AL/M	40
CMX11/AL/M	32	CLAMP SHAFT / METRIC	36	CMR05/AL/M	40
CMX12/AL/M	32	CMXC25Z/A/M	36	CMR07/AL/M	40
CMX13/AL/M	32	CMXC30Z/A/M	36	EU STYLE RUDDER / TRIM TAB	40
CMX14/A/M	32	CMXC35Z/A/M	36	CMF50Z/A/M	40
CMX15/AL/M	32	CMXC40Z/A/M	36	CMF70Z/A/M	40
CMX17/AL/M	32	CMXC45Z/A/M	36	CMF90Z/A/M	40
CMX18/AL/M	32	CMXC50Z/A/M	36	CMF110Z/A/M	40
CMX19/AL/M	32	CMXC60Z/A/M	36	CMF125Z/A/M	40
CMX20/AL/M	32	CMXC70Z/A/M	36	CMF140Z/A/M	41
CMX21/AL/M	33	CLEARANCE SHAFT / IMPERIAL	37	CMF190Z/A/M	41
STREAMLINED SHAFT / METRIC	33	CMC01/AL/M	37	CMF50CZ/A/M	41
CMXM20Z/A/M	33	CMC02/AL/M	37	CMF70CZ/A/M	41
CMX22Z/AL/M	33	CMC03/AL/M	37	CMF90CZ/A/M	41
CMX25/AL/M	33	CMC04/AL/M	37	CMF110CZ/A/M	41
CMX28/AL/M	33	CMC05/AL/M	37	CMF125CZ/A/M	41
CMX30/AL/M	33	CMC06/AL/M	37	CMF140CZ/A	41
CMX34/AL/M	33	CMC07/AL/M	37	SPAN. STYLE RUDDER / TRIM TAB	41
CMX35/AL/M	33	CMC08Z/AL/M	37	CMF70SPZ/A/M	41
CMX40/AL/M	33	CMC09/AL/M	37	CMF90SPZ/A/M	41
CMX45/AL/M	33	CMC09A/AL/M	37	CMF130SPZ/A/M	41
CMX50/AL/M	33	CMC12/AL/M	37	PLEASURECRAFT PROPELLER	42
CMX55/AL/M	33	CMC12A/AL/M	37	PROPELLER NUT	43
CMX60/A/M	33	CMC13/AL/M	37	CMPNAZC13/AC13/MC13	43
CMX65/A/M	34	CMC14/AL/M	37	CMPNBZC11/AC11/MC11	43
CMX70/A/M	34	CMC15/AL/M	38	CMPNCZC10/AC10/MC10	43
CMX75/A/M	34	CLEARANCE SHAFT / METRIC	38	CMPNCZF16/AF16/MF16	43
CMX80/A/M	34	CMC20/AL/M	38	CMPNDZC09/AC09/MC09	43
CMX85/A/M/	34	CMC25/AL/M	38	CMPNDZF14/AF14/MF14	43
CMX90/A/M	34	CMC30/AL/M	38	CMPNEZC08/AC08/MC08	43
CMX95Z/A/M	34	CMC35/AL/M	38	CMPNEZF14/AF14/MF14	43
CMX100/AL/M	34	CMC40/AL/M	38	CMPNFZC07/AC07/MC07	43
CMX110/A/M	34	CMC45/A/M	38	CMPNGZC07/AC07/MC07	43
CMX115Z/A/M	34	CMC50/A/M	38	CMPNHZC06/AC06/MC06	43
CMX120Z/A/M	34	CMC55Z/A/M	38	REPLACEMENT PROPELLER NUT	44
CMX123Z/A/M	34	CMC60/A/M	38	CMPNZA/AA/MA	44
CMX125Z/A/M	34	CMC65Z/A/M	38	CMPNZB/AB/MB	44
HD STREAMLINED SHAFT / METRIC	35	CMC70/A/M	38	CMPNZC/AC/MC	44
CMX09HDZ/A/M	35	CMC75/A/M	38	CMPNZD/AD/MD	44
CMX10HDZ/A/M	35	CMC80/A/M	39	CMPNZE/AE/ME	44
CMX11HDZ/A/M	35	CMC85Z/A/M	39	CMPNZF/AF/MF	44
CMX12HDZ/A/M	35	CMC90/A/M	39	CMPNZG/AG/MG	44

CMPNZH/AH/MG	44	CMMP63MZ/A/M	51	CMPNRAD100Z/A/M	56
AUTOPROP™	44	CMMP70MZ/A/M	51	REGGIANI™	57
CMPNH5Z/A/M	44	CMMP83MZ/A/M	51	CMRG20Z/A/M	57
CMPNH6Z/A/M	44	CMMP100MZ/A/M	51	CMRG25Z/A/M	57
CMPNH9Z/A/M	44	CMMP125MZ/A/M	51	CMRG30Z/A/M	57
BENETEAU™	45	CMMP70SDZ/A/M	51	CMRG35Z/A/M	57
CMLAEC3250/A/M	45	CMMP83SDZ/A/M	51	CMRG40Z/A/M	57
CMLAEC3300/A/M	45	CMMP63M2BZ/A/M	52	CMRG45Z/A/M	57
CMLAEC3500/A/M	45	MTF™	52	CMRG50Z/A/M	57
CMLAEC4000/A/M	45	CMMTF1Z/A/M	52	CMRG55Z/A/M	57
CMLAEC4500/A/M	45	CMMTF2Z/A/M	52	CMRG60Z/A/M	57
CMLAEC4500EUZ/A/M	45	CMMTF3Z/A/M	52	RIVA™	58
CMLAEC5000/A/M	45	RADICE™	52	CMOU686Z/A/M	58
CMLAEC5500/A/M	45	CMLAEC3250EUZ/A/M	52	CMRV221615Z	58
CMLAEC6000/A/M	45	CMLAEC3300EUZ/A/M	52	CMRV221620Z	58
CMLAEC10000/A/M	45	CMLAEC3500EUZ/A/M	52	CMRV2518175Z/A/M	58
BENETEAU™ REPLACEMENT	46	CMLAEC4000EUZ/A/M	52	CMRV251815Z/A/M	58
CMAN225/A/M	46	CMLAEC4500EUZ/A/M	53	CMRV251820Z	58
CMAN230/A/M	46	CMLAEC5000/A/M	53	CMRV302015Z	58
CMAN235/A/M	46	CMLAEC5500/A/M	53	CMRV352420Z	58
CMAN240/A/M	46	CMLAEC6000/A/M	53	CMRV402620Z	58
CMAN245/A/M	46	CMLAEC10000/A/M	53	CMRV2230	58
CMANCHN700/A/M	46	RADICE™ REPLACEMENT	53	CMRV3550	58
CMAN245EUZ/A/M	46	CMAN225EUZ/A/M	53	INTERNAL SQUARE	58
CMAN250/A/M	46	CMAN230EUZ/A/M	53	CMIQ648Z	58
CMAN255/A/M	46	CMAN235EUZ/A/M	53	SHAFRAN™	59
CMAN260/A/M	46	CMAN240EUZ/A/M	54	CMSH579Z	59
FERRETTI™	47	CMAN245EUZ/A/M	54	CMSH587Z	59
CMFE1Z/A/M	47	CMAN250/A/M	54	CMSH649Z	59
CMFE2Z/A/M	47	CMAN255/A/M	54	CMSH650Z	59
CMFE3Z/A/M	47	CMAN260/A/M	54	CMSH651Z	59
CMFE80Z/A/M	47	WASHRAD2225C	54	CMSH732Z/A/M	59
CMFE4Z/A/M	47	WASHRAD30C	54	SOLE™	59
CMFE5Z/A/M	48	WASHRAD35C	54	CMPNSOLE1/A/M	59
FLEXOFOLD™	48	WASHRAD40C	54	CMPNSOLE2/A/M	59
SGFF652Z/A/M	48	WASHRAD45C	54	CMPNSOLE3/A/M	59
CMPNFXZ/A/M	48	WASHRAD50C	54	CMPNSOLE4/A/M	59
CMPNFF2Z/A/M	48	WASHRAD55C	54	PLEASURECR. PROP NUT&BOW THR.	60
CMPNFF2KITZ/A/M	48	WASHRAD60C	54	LEWMAR™	61
GORI™	49	WASHRAD100C	54	CM589150Z/A/M	61
CM14072100Z/A/M	49	RADICE™ / HEXAGONAL	55	CM589350Z/A/M	61
CM14073100Z/A/M	49	CMPNRAD225C/A/M	55	CM589550Z/A/M	61
CM14074100Z/A/M	49	CMPNRAD30C/A/M	55	LEWMAR™ KITS	61
CM14074511Z/A/M	49	CMPNRAD35C/A/M	55	CM589150KITZ/A/M	61
CM15539500Z/A/M	49	CMPNRAD40C/A/M	55	CM589350KITZ/A/M	61
CM15540000Z/A/M	49	CMPNRAD45C/A/M	55	CM589550KITZ/A/M	61
CM15530000Z/A/M	49	CMPNRAD50C/A/M	55	MAX POWER™	61
CM15500000Z/A/M	49	CMPNRAD55C/A/M	55	CMMP586Z/A/M	61
CM15670000Z/A/M	49	CMPNRAD60C/A/M	55	CMMP676Z/A/M	61
CM15527500Z/A/M	49	CMPNRAD100C/A/M	55	PLEASURECRAFT HULL	62
J-PROP™	50	RADICE™ REPLACEMENT / HEX	56	CMGROUPER/A/M	63
CMJPROP60Z/A/M	50	CMPNRAD225C/A/M	56	DIVER'S DREAM	64
CMJPROP80Z/A/M	50	CMPNRAD30C/A/M	56	CMDIVERBONDA	64
CMJPROP90Z/A/M	50	CMPNRAD35C/A/M	56	CMDIVERMINI/A/M	64
CMJP60Z/A/M	50	CMPNRAD40C/A/M	56	CMDIVERZ/A/M	65
MAX PROP™	50	CMPNRAD45C/A/M	56	CMDIVERHZ/A/M	65
CMMP63RZ/A/M	50	CMPNRAD50C/A/M	56	CMDIVERMINIHZ/A/M	65
CMMP70RZ/A/M	50	CMPNRAD55C/A/M	56	CMZ10Z/A/M	65
CMMP83RZ/A/M	50	CMPNRAD60C/A/M	56		

HULL ANODES	66	CMRF484Z	73	BRP™ KITS	84
CMM24Z/A/M	66	CMSH090Z	74	CMSTRGERKITZ/A/M	84
CMM25/A/M	66	CMSH091Z	74	CMCOBRAKITZ/A/M	84
CMM30/A/M	66	CMSH125Z	74	CMETECG2KITZ/A/M	84
CMM40/A/M	66	CMSH126Z	74	CMOMC5075KITZ/A/M	84
CMMZ404/A/M	67	CMSH127Z	74	CMOMCV4V6KITZ/A/M	84
CMMZC406/A/M	67	RP SERIES ROUND PLATE	74	BMW™	85
CMN1Z/A/M	67	CMRP4Z/A/M	74	CMBW175Z	85
CMN1HZ/A/M	67	CMRP5Z/A/M	74	CMBW499Z	85
CMPMWZ/A/M	67	CMRP6SZ/A/M	74	CMBW172Z	85
CMPNWZ/A/M	67	CMRP6Z/A/M	74	CMBW173Z	85
CMPOWZ/A/M	67	CMRP7Z/A/M	74	CMBW043Z	85
CMPPWZ/A/M	67	CMRP8Z/A/M	74	CMBW044Z	85
CMAC073Z/A/M	68	CMRP9Z/A/M	74	BUKH™	86
CMPO029Z/A/M	68	ROUND PLATE	75	CMB00E5829Z/A/M	86
CMCH006Z	68	SGBA001Z/A/M	75	CMB00E0450/A/M	86
CMZH470Z	68	SGBA506Z/A/M	75	CASTOLDI™	86
CMZH058Z	68	SGBA597Z/A/M	75	CM590140552Z/A/M	86
CMZH058NZ	68	CMF90BZ/A/M	75	CM590163243Z/A/M	86
CMT20/A/M	69	PLEASURECRAFT INB/OUTB/STERN	76	CM59066209Z/A/M	86
CMT21/A/M	69	BRP™ OMC / JOHNSON EVINRUDE	77	HIDEA™	86
CMZ24BSZ/A/M	69	CM123009Z/A/M	77	CM6J81132500Z/A/M	86
CMZHC2Z/A/M	69	CM327606Z/A/M	77	HONDA™	87
CMZHC5AZ/A/M	69	CM334451Z/A/M	77	CM06411ZV5Z/A/M	87
CMPL505Z/A/M	70	CM338635Z/A/M	77	CM06411ZW1Z/A/M	87
SGFL501Z/A/M	70	CM355964Z/A/M	77	CM41109ZW1003Z/A/M	87
CMZH479Z/A/M	70	CM357507Z/A/M	77	CM6644537101Z/A/M	87
CMZH494Z/A/M	70	CM367Z/A/M	77	CM41107ZV500Z/A/M	88
CMZH504Z	70	CM389999Z/A/M	78	CM41107ZW1B01Z/A/M	88
SGAO072Z/A/M	71	CM392123Z/A/M	78	CM41107ZW1003Z/A/M	88
CMFL075Z/A/M	71	CM392462Z/A/M	78	CM41109ZW1B00Z/A/M	88
CMFL074Z/A/M	71	CM393023Z/A/M	78	CM6E04525111Z/A/M	89
CMFL076Z/A/M	71	CM395780Z/A/M	78	CM41106ZW9000Z/A/M	89
CMRF104Z/A/M	71	CM397768Z/A/M	79	HONDA™ KITS	89
CMZH480Z/A/M	71	CM398331Z/A/M	79	CMHBF75115KITZ/A/M	89
CMSH505Z/A/M	71	CM398873Z/A/M	79	CMHBF4050KITZ/A/M	89
CMSH514	71	CM431708Z/A/M	79	CMHBF35225KITZ/A/M	89
SGPL356Z/A/M	71	CM434029Z	79	KAMEWA™	90
SGPL576Z/A/M	71	CM5007089Z/A/M	80	CMKA614Z/A/M	90
SGPL355Z/A/M	72	CM5008813Z/A/M	80	CMKA615Z/A/M	90
SGPL573Z/A/M	72	CM5009138Z/A/M	80	CMKA616Z/A/M	90
SGPL572Z/A/M	72	CM5031538Z/A/M	80	CMKA617Z/A/M	90
SGSH16Z/A/M	72	CM5031705Z	80	CMKA730Z/A/M	90
SGSH25Z/A/M	72	CM5032929Z/A/M	80	CMKA618Z/A/M	90
SGVT070Z/A/M	72	CM5512595500Z/A/M	81	CMKA619Z/A/M	90
SGVT507Z/A/M	72	CM5532098400Z/A/M	81	CMKA620Z/A/M	90
SGVT240Z/A/M	72	CM5532098600Z/A/M	81	CMKA621Z/A/M	90
SGVT695Z/A/M	72	CM5532187J00Z/A/M	81	CMKA622Z/A/M	91
CMPL078Z/A/M	73	CM5532190J01Z/A/M	81	CMKA623Z/A/M	91
CMPL419Z	73	CM5532193900Z	81	CMKA624Z/A/M	91
CMPL400Z/A/M	73	CM980756Z/A/M	82	SGPL573Z/A/M	91
CMPL401Z/A/M	73	CM982277Z/A/M	82	LOMBARDINI™	91
CMPL378Z/A/M	73	CM982438Z	82	CM9135033Z/A/M	91
CMFL075FZ/A/M	73	CM983494Z/A/M	82	CM9135034Z/A/M	91
CMFL076FZ/A/M	73	CM983952Z/A/M	83	MERCURY™/MERCUISER™	92
CMPL357Z/A/M	73	CM984513Z/A/M	83	CM09411Z/A/M	92
CMFL465Z/A/M	73	CM984547Z/A/M	83	CM31640Z/A/M	92
CMPL574Z/A/M	73	CM986158Z/A/M	83	CM34127Z/A/M	92
CMZH054Z	73	CM987067Z/A/M	83	CM34762Z/A/M	92

CM42121Z/A/M	92	CM821630KITA/M	104	CM5532098600Z/A/M	114
CM43396Z/A/M	93	CM821631KITA/M	104	CM5532098400Z/A/M	114
CM43994Z/A/M	93	CM826134KITA/M	104	CM5532190J01Z/A/M	115
CM46399Z/A/M	93	CM865182KITA/M	104	CM5512587E01Z/A/M	115
CM47820A1Z/A/M	93	CM762144KITA/M	105	CM4181198500Z/A/M	115
CM55989Z/A/M	93	CM762145KITA/M	105	CM5532193900Z/A/M	115
CM762144Z/A/M	94	CM806105KITA/M	105	CM5530095500Z/A/M	115
CM762145Z/A/M	94	CM806188KITA/M	105	CM5532187J00Z/A/M	115
CM76214Z/A/M	94	CM806189KITA/M	105	SUZUKI™ KITS	116
CM76214Q5Z/A/M	94	CM806190KITA/M	105	CMSZ4050KITZ/A/M	116
CM804079002Z/A/M	94	NISSAN™ TOHATSU™	106	CMSZ90140KITZ/A/M	116
CM806105Z/A/M	94	CM338602182Z/A/M	106	CMSZ150350KITZ/A/M	116
CM806188Z/A/M	95	CM3C7602181A0Z/A/M	106	VOLVO PENTA™	116
CM806189Z/A/M	95	CM5338602182A0Z/A/M	106	CMV15/A/M	116
CM806190Z/A/M	95	CM3H660218000Z/A/M	106	CMV16/A/M	116
CM818298Z/A/M	95	CM3V1602170Z/A/M	106	CMV17/A/M	117
CM821629CZ/A/M	95	CM348602170Z/A/M	107	CMV18/A/M	117
CM821630C2Z/A/M	95	CM3C86021700Z/A/M	107	CM21718129Z/A/M	117
CM821631Z/A/M	96	CM3B76021700Z/A/M	107	CM22651246Z	117
CM822157C2Z/A/M	96	CM3B7602181Z/A/M	107	CM358407Z/A/M	117
CM822777Z/A/M	96	CM369602181Z	107	CM3588745Z/A/M	117
CM8239121Z/A/M	96	CM3M2602181Z/A/M	107	CM3593881Z/A/M	118
CM823912Z/A/M	96	PAINIER™	108	CM3589875Z/A/M	118
CM825271Z/A/M	97	CM6634525100Z/A/M	108	CM3841427Z/A/M	118
CM826134Z/A/M	97	CM63D4525101Z/A/M	108	CM3852970Z/A/M	118
CM826887MZ/A/M	97	CM6H31132501Z/A/M	108	CM3854130Z/A/M	118
CM847635001Z/A/M	97	PARSUN™	108	CM3855411Z/A/M	119
CM856581CZ/A/M	97	CM6G81132500Z/A/M	108	CM3861636Z/A/M	119
CM85824A3Z/A/M	97	CM8018Z/A/M	109	CM3861634Z/A/M	119
CM880653Z/A/M	98	CM66M1132500Z/A/M	109	CM3863206Z/A/M	119
CM892227Z/A/M	98	CM6E51132500Z/A/M	109	CM3883728Z/A/M	119
CM89949Z/A/M	98	CM6821132500Z/A/M	109	CM40005206Z/A/M	120
CM8M0001734Z/A/M	98	CM62Y1132500Z/A/M	109	CM832598Z/A/M	120
CM8M0012083Z/A/M	99	CM6764525100Z/A/M	110	CM838929Z/A/M	120
CM8M0039340Z/A/M	99	CM67C4525100Z/A/M	110	CM823661Z/A/M	120
CM8M0057772Z/A/M	99	CM6761132500Z/A/M	110	CM852018Z/A/M	121
CM94286T1Z/A/M	99	CM6881132500Z/A/M	110	CM852835Z/A/M	121
CM984325Z	100	CM6891132500Z/A/M	110	CM872793Z/A/M	121
CMPNCZF16	100	RENAULT™	111	CM873395Z/A/M	121
CMPNDZ/A/M/F14UNS	100	CMRE16Z/A/M	111	CM872139Z/A/M	121
CMPNEZ/A/M/F14	100	CMRE20Z/A/M	111	CM875812Z/A/M	122
MERCURY™ KITS	101	CMRE28Z/A/M	111	CM875821Z/A/M	122
CM8M0039340KITZ/A/M	101	CMRE50Z/A/M	111	CM40005875Z/A/M	122
CM8M0107548KITZ/A/M	101	CM9005660Z/A/M	111	CM832934Z/A/M	122
CM8M0116590KITZ/A/M	101	CM2500050Z/A/M	111	CM855105Z/A/M	123
CMM3060KITZ/A/M	101	SELVA™	112	CM833913Z/A/M	123
CMALPHAKITZ/A/M	102	CM2500065Z	112	CM833915Z/A/M	123
CMBRAVO1KITZ/A/M	102	CM2504015Z/A/M	112	CM828140Z/A/M	123
CMBRAVO23KITZ/A/M	102	CM82795MZ/A/M	112	CM876638Z/A/M	123
CMBRAVO3KITZ/A/M	102	CM67C4525100Z/A/M	112	SGSP71180Z/A/M	123
CM31640KITA/M	102	SUZUKI™	113	CM41100098Z/A/M	123
CM55989KITA/M	102	CM5512587D00Z/A/M	113	CM41100276Z/A/M	124
CMM3060KITZ/A/M	103	CM551259630Z/A/M	113	CM8520219Z/A/M	124
CMM75115KITZ/A/M	103	CM5532095310Z/A/M	113	VOLVO PENTA™ KITS	124
CMALPHAGEN1KITZ/A/M	103	CM5532194900Z/A/M	113	CM280KITZ/A/M	124
CMVERADO4KITA/M	103	CM1113094600Z/A/M	113	CM280DPKITZ/A/M	124
CMVERADO6KITA/M	103	CM5512595301Z/A/M	114	CM290KITZ/A/M	124
CM818298KITA/M	104	CM5512595500Z/A/M	114	CM290DPKITZ/A/M	125
CM821629KITA/M	104	CM5512594502Z/A/M	114	CMDPHKITZ/A/M	125

CMSXKITZ/A/M	125	CM6884525101Z/A/M	137	CME5	144
CMSXAKITZ/A/M	125	CM6884537102Z/A/M	137	CME2BSP	144
CM3858399KITZ/A/M	125	CM6891132500Z/A/M	137	CME3BSP	144
CM290EUKITZ/A/M	126	CM69L4537100Z/A/M	138	CME0AZ	144
CM290DPEUKITZ/A/M	126	CM825271Z/A/M	138	CME2BZ	144
CM3584442KITZ/A/M	126	CM82795MZ/A/M	138	CMEP00	145
CMVPIPSKITZ/A/M	126	YAMAHA™ KITS	138	CMEP0	145
YAMAHA™	126	CMY150KITA/M	138	CMEP1	145
CM41106ZW000Z/A/M	126	CMY150CRKITA/M	138	CMEP2	145
CM42121Z/A/M	127	CMY200250KITA/M	139	CMEP3	145
CM6AW4525100Z/A/M	127	CMYHP200300KITA/M	139	CMEP2BSP	145
CM6AW4537300Z/A/M	127	CMY300350KITZ/A/M	139	CMEP3BSP	145
CM6AW4561900Z/A/M	127	CMY300350XPKITZ/A/M	139	CMEZ00	145
CM6BL1132500Z/A/M	127	CMY4050KITZ/A/M	139	CMEZ0	145
CM6E04525111Z/A/M	128	CMY4060KITZ/A/M	139	CMEZ1	145
CM6E51132500Z/A/M	128	CMY6090KITZ/A/M	140	CMEZ0AZ	145
CM6E54525100Z/A/M	128	CMY80100KITZ/A/M	140	CMEZ2BZ	145
CM6E54537101Z/A/M	128	BENNETT TRIM TAB™	141	CMEZ1D	145
CM6E84525100Z/A/M	128	CMBNT1AZ/A/M	141	CMEZ1E	145
CM6G54525101Z/A/M	129	CMBNT1AKITZ/A/M	141	CMEZ1F	145
CM6G81132500Z/A/M	129	DE-ICER/AERATOR	141	CMEZ1G	145
CM6G84525101Z/A/M	129	CMDEICERZ/A/M	141	CMEZ1H	145
CM6H14525101Z/A/M	129	FRIGO-BOAT™	141	CMEZ2	145
CM6H14525102Z/A/M	129	CM51525Z/A/M	141	CMEZ2S	145
CM6J94537101Z/A/M	130	GROUND PLATE	141	CMEZ3	145
CM6K14537100Z/A/M	130	10421419	141	CMEZ3S	145
CM6K14537102Z/A/M	130	10421420	141	CMEZ4	145
CM6L54525102Z/A/M	130	10421421	141	CMEZ5	145
CM6E54537110Z/A/M	130	10421422	141	CM8105277Z	146
CM6E84525102Z/A/M	131	LINE CUTTER	142	CM8105277PZ	146
CM6G14525102Z/A/M	131	CMLCAZ/A/M	142	CMEBP1018	146
CM6G14525103Z/A/M	131	CMLCBZ/A/M	142	CM8101772Z	146
CM6T44583600Z/A/M	131	CMLCCDEZ/A/M	142	CM8101772PZ	146
CM6T54537100Z/A/M	131	CMLCF1Z/A/M	142	CMEBP1428	146
CM6T54537300Z/A/M	132	SEA STRAINER	142	CMAF920Z	146
CM6U04525100Z/A/M	132	CMSZ1Z/A/M	142	CMAF920PZ	146
CM6U34525101Z/A/M	132	CM656934Z/A/M	142	CMEBP4512	146
CM6U44525100Z/A/M	132	TWIN DISC™	143	CM8109743Z	146
CM6U44537300Z/A/M	133	ARNSMALL/A/M	143	CM8109743PZ	146
CM61A1132500Z/A/M	133	ARNLARGE/A/M	143	CMEBP712	146
CM61A4537100Z/A/M	133	CMFL465Z/A/M	143	CMAF720Z	146
CM61N4525101Z/A/M	133	CMAR580Z/A/M	143	CMEAF720PZ	146
CM62Y1132500Z/A/M	133	CMAR670Z	143	CMEBP510	146
CM63D4525101Z/A/M	134	CMAR671Z	143	CMEBD20Z	146
CM63P1132501Z/A/M	134	CMAR672Z	143	CMEBD20PZ	146
CM63P1132511Z/A/M	134	ENGINE COOLING SYSTEM	144	CMEBP824	146
CM66M1132500Z/A/M	134	CME00	144	CMB00E0450	146
CM66M4537100Z/A/M	134	CME0	144	CM8515850Z	147
CM6644537101Z/A/M	135	CME1	144	CM6L2288Z	147
CM67C4525100Z/A/M	135	CME1D	144	CM6L2289Z	147
CM67C4537100Z/A/M	135	CME1E	144	CM6L2289PZ	147
CM67F1132500Z/A/M	135	CME1F	144	CMEBP3812	147
CM67F1132501Z/A/M	135	CME1G	144	CM6L2283Z	147
CM67F4537100Z/A/M	136	CME1H	144	CM6L2283PZ	147
CM6794525100Z/A/M	136	CME2	144	CM6L3104Z	147
CM68T1132500Z/A/M	136	CME2S	144	CM6L3104PZ	147
CM68T4525100Z/A/M	136	CME3	144	CMEBP1414	147
CM68V1132501Z/A/M	137	CME3S	144	CM6L2016Z	147
CM6881132500Z/A/M	137	CME4	144	CM6L2016PZ	147

CMEBP5834	147	CMSC1663PZ	150	CMZ04SA/SM/SZ/AA/AM/AZ/GM/GZ	163
CM6L2285Z	147	CM1331818Z	150	CMHT1/A	163
CM6L2284Z	147	CM1331818PZ	150	CMZD77EURO/A/M	163
CM6L2280GZ	147	CMEBP612	150	CM273125GZ/A	164
CM6L2280GPZ	147	CMSC1645Z	150	CM39315GZ/A	164
CMEBP71638	147	STE217841Z	151	CMMZC406/A/M	164
CMCA1230Z	147	CMVM40Z	151	CMZC7SA/SZ/AA	164
CMCU1650Z	148	CMVM40PZ	151	CMZHC06GBZ/A	164
CMCU1650PZ	148	CMVMBP8	151	CMZSC12Z/A/M	164
CMEBP1212	148	CMVM20Z	151	CMMGJRG	165
CMECU16Z	148	CMVM20PZ	151	CMDIVERZ/A/M	165
CMECU16PZ	148	CMVMM10Z	151	CM36BSSZ/A	165
CMEBP71612	148	CMVMM10PZ	151	CMZD78B/A	165
CMCU1020Z	148	CMVMBP10	151	CM1661GZ/A	165
CMCU1020PZ	148	CM8517479Z	151	CMZ03B/A/Z/GA/GZ/AA/AZ	166
CMEBP638	148	CM838929Z/A/M	151	CMH06Z/A	166
CMCU1865Z	148	CMEZ2S	151	CMF125PB4TPZ/A/M	166
CMCU1645Z	148	CM823661Z/A/M	151	CMZ03BZ/A/AA	166
CMFO1018Z	148	CMVP16520Z	151	CMCDZ886SZ/A/M	166
CMFO1018PZ	148	CM27210200370Z	152	CMZ03SA/SM/SZ/AA/AM/AZ/GA/GZ	166
CMEBP8514	148	CM27210200550Z	152	CMZ15BZ/A	167
CMFO1332Z	148	CM12065013420Z	152	CMZD72BM/MM/MA	167
CM8517479Z	148	CMEBP71618	152	CM810SZ/A	167
CM8517479PZ	148	CM12065013420PZ	152	CMZL18BGZ/A/M	167
CMEBP716B12	148	COMMERCIAL HULL	156	CMH20BZ/A/M	167
CMEZ2	148	HULL	157	CMMG5GM	167
CM8517480BSZ	148	CM656934Z/A/M	157	CM812125SZ/A/GA/GZ	168
CMEBP71612L	148	CMT20/A/M	157	CMCDZ8126SZ/A/M	168
CMEZ2S	148	CM200Z/A/M/AA	157	CMZ19SZ/A	168
CM8517479BSZ	148	CMM24Z/A/M	157	CMZ24BSZ/A	168
CMEZ4SL	148	CMZ12SA/AZ	157	CMZ01BSZ/A/M	168
CM8515842BSZ	148	CM335Z/A/M	158	CMZ02Z/A	168
CMEP5834	148	CMT21/A/M	158	CMZ22Z/A/M/AA/AM/AZ/GM	169
CM8515850Z	148	CM500Z/A/M/AA	158	CMP5B2BZ/A/GSA/GSZ/AA/AZ	169
CM8515851Z	148	CMZ13AZ/SA	158	CMZD72BZ	169
CM8515842Z	148	CMZD56/A/M	158	CMZ26SZ/A/AA/GZ/SZ	169
CM8925832Z	148	CMM30/A/M	159	CMH19BZ/A/M	169
CMIF2034Z	149	CM35GZ/A	159	CM812SZ/A/GA/GZ	170
CMIF2034PZ	149	CMZHC3AZ/A/M	159	CMM120BZ/A	170
CM970494635Z	149	CMZHC2AZ/AA/AM	159	CMMA2204SZ/A/GA/GZ	170
CM970494635PZ	149	CMM40/A/M	159	CMMG10GM	170
CMEBP816	149	CM1000Z/A/M/AA	160	CMP7B2BSZ/A	170
CMNN2525Z	149	CMDIVERMINI/A/M	160	CMZHC47SA/CMAHC20SBS/CMZHC47SZ/ CMZHC42SBS	170
CMNN2525PZ	149	CMN1Z/A/M	160	CMZHS47SA/CMAHS20S/CMZHS47SZ/ CMZHS42S	171
CMEBP2230	149	CMN1HZ/A/M	160	CMMA2244LZ/A	171
CMON1030Z	149	CMH18BZ	160	CMMA2244SZ/A	171
CM1301341PZ	149	CM2431GZ/A	160	CM260SZ/A	171
CMEBPD838	149	CMZ06SA/SM/SZ/AA/AM/AZ/GM/GZ	161	CM260BSZ/A	171
CMON1131Z	149	CMMZ404/A	161	CMMG24GM	171
CMON1131PZ	149	CMZ14AZ/SA/AAW	161	CMMA3305SZ/A	172
CMEBP838	149	CMM25/A/M	161	CMMA3365CSZ/A	172
CMON1326Z	149	CM37GZ/A	161	CMMA4545CSZ/A	172
CMERE14Z	150	CMARCHN/A	162	BALLAST TANK	173
CMERE14PZ	150	CM2000Z/A/M/AA	162	CMMA2602SZ/A	173
CMEREBP18	150	CM2631GZ/A	162	CMMA3602SZ/A	173
CMHS1760Z	150	CMZHC5AZ/A/M	162	CMMA31003Z/A	173
CMHS1760PZ	150	CMZD58/A	162	CMMA41004Z/A	173
CMEPHS1420	150	CMZC5SA/SZ/AA/AZ	163		
CMSC1763Z	150	CMZTSA/SZ/AA/AZ/GA/GZ	163		

CABLE ANODES	173	CMP05612Z/A	177	JDDM20Z/A	182
CMTYPE3Z/A	173	CMP075106Z/A	177	JDB3GBZ/A	183
CONDENSER ANODES	173	CMP075303Z/A	177	JDP320224Z	183
CMC6C50BZ/A	173	CMP075306Z/A	177	JDDM28GBZ/A	183
CMC6C75BZ/A	173	CMP075606Z/A	177	JDH62GBZ/A	183
CRAB TRAP	174	CMP075612Z/A	177	JDH49GBZ/A	183
CMZCT2WZ/A	174	CMP1206Z/A	177	JDH56GBZ/A	184
CMCTHBZ/A/M	174	CMP1303Z/A	177	JDH10GZ/A	184
HEAT EXCHANGER	174	CMP1304Z/A	177	JDB4GBZ/A	184
CMH2B2Z/A	174	CMP1306Z/A	177	JDH55GBZ/A	184
CMH2B3Z/A	174	CMP1406Z/A	177	JDS4GZ/A	184
CMH2B4Z/A	174	CMP1606Z/A	177	JDGBZH02Z/A	185
CMH2B5Z/A	174	CMP1612Z/A	177	JDDM45Z/A	185
CMH2B6Z/A	174	CMP075406Z/A	177	JDH50GBZ/A	185
CMH2B11Z/A	174	CMP11504Z/A	177	JDH53GBZ/A	185
CMH1B6GZ/A	174	CMP11505Z/A	177	JDB8GBZ/A	185
OLYMPIC™ DRIVE	175	CMP166Z/A	178	JDDM60GZ/A	186
CMOLY/A	175	CMP631Z/A	178	JDH61GBZ/A	186
CMOLY1HZ/A	175	CMP05306WZ	178	JDS8GZ/A	186
PLATFORM/STANDOFF	175	CMP05606WZ	178	JDH63GBZ/A	186
TYPE1	175	CMP05612WZ/A	178	JDH51GZ/A	186
TYPE2	175	CMP075306WZ/A	178	JDB9GBZ/A	187
HEATER TREATER	175	CMP075406WZ/A	178	JDH01Z/A	187
CMHT321Z/A	175	ROD STOCK	178	JDS9GZ/A	187
CMHT330Z/A	175	CMR0512Z	178	JDDM96GZ/A	187
PROP NUT	175	CMR062512Z	178	JDH47GBZ/A	187
CMPN01Z/A	175	CMR07512Z	178	JDH7GZ/A	187
CMPN02Z/A	175	CMR1524Z	178	JDH21GBZ/A	188
CMPN03Z/A	175	CMR224Z	178	JDH52GZ/A	188
CMPN04Z/A	175	CMR324Z	178	JDS9EGZ/A	188
CMPN05Z/A	175	CMR037536Z	178	JDH13GBZ/A	188
CMPN06Z/A	176	CMR0536Z	178	JDH26GZ/A	188
CMPN07Z/A	176	CMR062539Z	178	JDH36GA	188
CMPN08Z/A	176	CMR07539Z	178	JDH60GZ/A	189
CMPN09Z/A	176	CMR087539Z	178	JDDM121GZ/A	189
CMPN10Z/A	176	CMR139Z	178	JDDM121GBZ/A	189
CMPN11Z/A	176	CMR12539Z	178	JDH6GZ/A	189
CMPN12Z/A	176	FERNSTRUM KEEL	179	JDH45GBZ/A	189
CMPN13Z/A	176	CM1874SZ/A/M	179	JDZD140GZ/A	189
CMPN13BZ/A	176	CM2624SZ/A/M	179	JDH23BZ/A	190
PLATE STOCK	176	CM2874SZ/A/M	179	JDH11GZ	190
CMPMA/CMPMWA	176	WALTER KEEL	179	JDGBZH01Z/A	190
CMPMZ/CMPMWZ	176	CMKK1Z/A/M	179	JDH5GZ/A	190
CMPNA/CMPNWA	176	CMKK2Z/A/M	179	JDDM155Z/A	190
CMPNZ/CMPNWZ	176	CMKK3Z/A/M	179	JDZD170GZ/A	190
CMPOA/CMPOWA	176	CMX453Z/A/M	179	JDH58GBZ/A	191
CMPOZ/CMPOWZ	176	CMX473Z/A/M	179	JDH15GZ/A	191
CMPPA/CMPPWA	176	CMX58Z/A/M	179	JDH37SZ/A	191
CMPPZ/CMPPWZ	176	COMMERCIAL HULL SPEC. ORDERS	180	JDH25SZ/A	191
CMP0515115Z/A	176	HULL (SPECIAL ORDERS)	181	JDH54GBZ/A	191
CMP051512Z/A	176	JDP320220Z	181	JDH35GZ/A	191
CMP05204Z/A	176	JDP320221Z	181	JDH40SBZ/A	192
CMP05212Z/A	176	JDP320222Z/A	181	JDDM217Z/A	192
CMP05224Z/A	176	JDB2GBZ/A	181	JDH17GZ/A	192
CMP05303Z/A	176	JDP320223Z	181	JDH4GZ/A	192
CMP05306Z/A	177	JDH39SBZ/A	182	JDH59GBZ/A	192
CMP05406Z/A	177	JDH24GZ/A	182	JDMA3305SZ/A	192
CMP05312Z	177	JDP320219Z	182	JDH34GZ/A	193
CMP05606Z/A	177	JDH48GZ/A	182	JDDM105GZ/A	193

JDH24GBZ/A	193
JDH22GZ/A	193
JDH22GBZ/A	193
JDE2GZ/A	193
JD485GZ/A	194
JDH27GZ/A	194
JDC1GZ/A	194
JDE3GZ/A	194
JDH3GZ/A	194
SGSH506Z/A/M	195
SGSH507Z/A/M	195
SGSH508Z/A/M	195
SGSH509Z/A/M	195
SGSH510Z/A/M	195
SGSH100Z/A/M	195
SGSH101Z/A/M	195
SGSH159Z/A/M	195
SGSH16Z/A/M	195
SGSH25Z/A/M	195
BALLAST TANK (SPECIAL ORDERS)	196
JDZT8GZ/A	196
JDT9GZ/A	196
JDI13GZ/A	196
JDT13GZ/A	196
JDGBZT01Z/A	196
JDT12GZ/A	196
JD237Z/A	197
JDT3GZ/A	197
JDT1GZ/A	197
JDI17GZ/A	197
JDT14GZ/A	197
JDT11GZ/A	197
JDT14GZF/AF	198
JDT15GZ/A	198
JDT16GZ/A	198
JDT19GZ/A	198
JDT22GZ/A	198
HEAT EXCHANGER	198
JDROD25DZ	198
JDROD69DZ	199
JDROD100DZ	199
JDROD25Z/A	199
JDROD30Z/A	199
JDROD40Z/A	199
JDROD45Z/A	199
JDROD50Z/A	199
JDROD55Z/A	199
JDROD60Z/A	199
JDROD65Z/A	199
JDROD70Z/A	199
JDROD75Z/A	199
JDROD80Z/A	199
JDROD85Z/A	199
JDROD90Z/A	199
JDROD95Z/A	200
JDROD100Z/A	200
JDROD105Z/A	200
JDROD110Z/A	200
JDROD115Z/A	200

PERFORMANCE

Martyr® Aluminum Premium and Martyr® Zinc Traditional Anodes

SPECIFICATIONS	Al premium <small>SALT AND BRACKISH WATER</small>	Zn traditional <small>SALT WATER ONLY</small>
CAPACITY, ampere-hours/lb (kg)	1225 (2695)	355 (782)
EFFICIENCY (test)	94%	95%
CONSUMPTION, lb(kg)/ampere-year	7.15 (3.25)	24.68 (11.2)
POTENTIAL (reference Cu/Cu SO4)	-1100mV	-1050mV

COMPOSITION

Martyr® Aluminum Premium and Martyr® Zinc Traditional Anodes

COMPOSITION	Al premium <small>SALT AND BRACKISH WATER</small> U.S. Military Specification* MIL-DTL-24779C(SH)	Zn traditional <small>SALT WATER ONLY</small> U.S. Military Specification* MIL-DTL-18001L
Cadmium	-	0.025% - 0.07%
Copper	0.005% Max.	0.005% Max.
Iron	0.08% Max.	0.005% Max.
Indium	0.014% - 0.020%	-
Lead	-	0.006% Max.
Silicon	0.08% - 0.20%	-
Aluminum	Remainder	0.1% - 0.5%
Zinc**	4.0% - 6.5%	Remainder

* Latest Revision ** Martyr® anodes have a zinc purity 99.995%

COMPARISON

Martyr® Aluminum Premium and Martyr® Zinc Traditional Anodes

Al premium SALT AND BRACKISH WATER

1225 Ampere hours per pound / 2695 Ampere hours per kilogram: this means an Aluminum anode will give one amp for 1225 hours for every pound of Aluminum

Take a typical CMZ03BA (weight = 2.26 kg) – total ampere hours 7277

Assuming the anode performs at 0.5 amp, this anode will last for 14554 hours, which is 606 days / 20 months

Zn traditional SALT WATER ONLY

355 Ampere hours per pound / 782 Ampere hours per kilogram: this means a Zinc anode will give one amp for 355 hours for every pound of Zinc

Take a typical CMZ03BZ (weight=5.2 kg) – total ampere hours 3655

Assuming the anode performs at 0.5 amp, this anode will last for 7310 hours, which is 305 days / 10 months

NEW PRODUCTS:

PLAN-O-GRAMS

HEAVY DUTY

SHAFT ANODES

LEWMAR™

MERCURY™

YAMAHA™

AND MORE

ANODES & KITS

MARTYR™ ANODE PLAN-O-GRAMS

Martyr™ Anode Plan-o-grams are designed to offer the most popular anodes including our top selling anode kits, a selection of shaft and rudder anodes and complimentary products in an easy merchandising option taking the guess work out of setting up an anode display.

These plan-o-grams are available in our **Al Premium** (Aluminum anodes), **Mg Fresh** (Magnesium anodes) assortments or a combination of those 2 alloys.

The Plan-o-gram Part ID would come with:

- Parts
- Header card
- Back up tags

Al premium
SALT AND BRACKISH WATER ◆

Mg fresh
FRESH WATER ONLY ●

- Perform at least 5% better than Traditional Zinc anodes in saltwater;
 - Protect 50% longer than Traditional Zinc anodes;
 - Are environmentally friendly – contain 0% Cadmium, a toxic material found in Traditional Zinc anodes;
 - Weigh 50% less than Traditional Zinc anodes;
 - Meet the US Military Specification Mil-DTL-24779C(SH);
 - Are the only anodes proven to be effective in Salt & Brackish water;
 - Results in considerable cost savings compared with Traditional Zinc anodes on commercial products.
- The only alloy proven to protect your boat in fresh water
 - FRESH water only
 - Not recommended for use in salt or brackish water
 - Are environmentally friendly – contain 0% Cadmium, a toxic material found in Traditional Zinc anodes;

Mercury™ Plan-o-grams:

- ALUMINUM ONLY PID:
CMMPOGA
- MAGNESIUM ONLY PID:
CMMPOGM
- COMBO PID:
CMMPOGAM



Yamaha™
Plan-o-grams:

- ALUMINUM ONLY PID:
CMYPOGA
- MAGNESIUM ONLY PID:
CMYPOGM
- COMBO PID:
CMYPOGAM



BRP™
Plan-o-grams:

- ALUMINUM ONLY PID:
CMBPOGA
- MAGNESIUM ONLY PID:
CMBPOGM
- COMBO PID:
CMBPOGAM



Volvo™
Plan-o-grams:

- ALUMINUM ONLY PID:
CMVPOGA
- MAGNESIUM ONLY PID:
CMVPOGM
- COMBO PID:
CMVPOGAM



To request our Plan-o-gram Brochure email us at marketing@canmet.com.

Choose
Aluminum

Al premium
SALT AND BRACKISH WATER





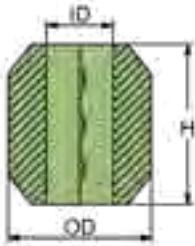





Anodes for
salt and brackish
water and
Magnesium

Mg fresh
FRESH WATER ONLY
for freshwater.

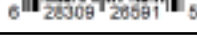

**INTERLOCKING
HALVES**

NEW HEAVY DUTY STREAMLINED SHAFT ANODES / metric

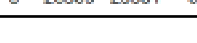
	PID	LB	KG		H	OD	ID	UPC
Al	CMX16HDA	15.83	7.18	mm	188	174.3	95	
Mg	CMX16HDM	10.12	4.59					
Zn	CMX16HDZ	40.86	18.53	in	7.40	6.86	3.75	
Al	CMX17HDA	14.75	6.69	mm	188	174.3	102	
Mg	CMX17HDM	9.44	4.28					
Zn	CMX17HDZ	38.04	17.25	in	7.40	6.86	4	
Al	CMX17LHDA	13.58	6.16	mm	188	174.3	108	
Mg	CMX17LHDM	8.71	3.95					
Zn	CMX17LHDZ	35.04	15.89	in	7.40	6.86	4.25	
Al	CMX18HDA	12.37	5.61	mm	188	174.3	114	
Mg	CMX18HDM	7.94	3.6					
Zn	CMX18HDZ	31.84	14.44	in	7.40	6.86	4.5	

The world's best shaft anode design:

- easy installation underwater: bolt retaining washers prevent the anode from falling off
- interlocking halves
- fit & longevity



Martyr
INTRODUCING NEW PRODUCTS

NEW ROUND PLATE ANODES

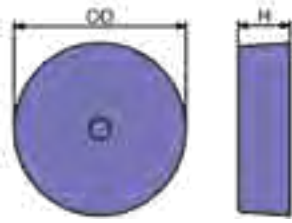

	PID	LB	KG		H	OD	UPC
Al	CMF90BA	0.831	0.377	mm	25	90	6 28309 24207 7
Mg	CMF90BM	0.527	0.239				6 28309 24333 3
Zn	CMF90BZ	2.17	0.984	in	1	3.5	6 28309 24129 2



NEW BOLT-ON HULL ANODES

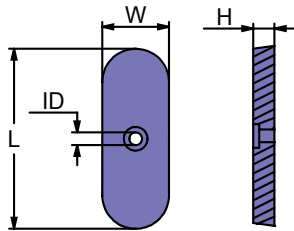

	PID	LB	KG		L	W	H	ID	UPC
Al	CMN1HA	1.892	0.858	mm	219	84	25.4	10	6 28309 27438 9
Mg	CMN1HM	1.206	0.547						6 28309 27440 5
Zn	CMN1HZ	4.904	2.224	in	8.63	3.31	1	0.4	6 28309 27438 2

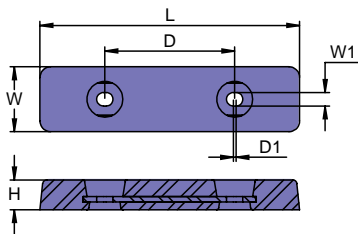

	PID	LB	KG		L	W	H	D	W1	D1	UPC
Al	CMZSC12A	4.5	2.04	mm	305	76	35	152	16	3	6 28309 27499 3
Mg	CMZSC12M	3.1	1.41								6 28309 27500 6
Zn	CMZSC12Z	10.4	4.72	in	12	3	1.375	6	0.63	0.12	6 28309 27498 6



INTRODUCING NEW PRODUCTS

NEW BRP™ ANODES

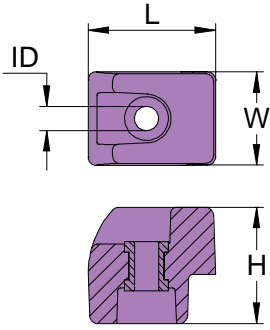

	PID	LB	KG		L	W	H	ID	UPC
Al	CM355964A	0.265	0.12	mm	46.6	34.25	42.5	8.15	6 28309 27559 4
Mg	CM355964M	0.176	0.08						6 28309 27582 4
Zn	CM355964Z	0.662	0.3	in	1.83	1.35	1.67	0.32	6 28309 27556 3

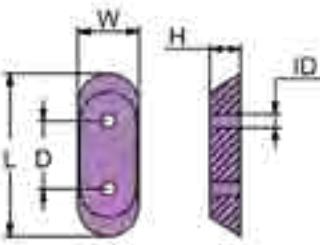

	PID	LB	KG		L	D	W	H	ID	UPC
Al	CM357507A	0.062	0.028	mm	61	25.4	22.86	10.92	7.37	6 28309 27560 0
Mg	CM357507M	0.039	0.018							6 28309 27563 1
Zn	CM357507Z	0.162	0.73	in	2.4	1	0.9	0.43	0.29	6 28309 27557 0



Martyr®
INTRODUCING NEW PRODUCTS

NEW BRP™ ANODE KIT



	PID	LB	KG	Contains	Fits	UPC
Al	CMETECG2KITA	2.002	0.917	CM5007089 X 1 CM355964 X 1	BRP EVINRUDE E-TEC G2	6 28309 27561 7
Mg	CMETECG2KITM	1.473	0.668	CM357507 X 1		6 28309 27564 8
Zn	CMETECG2KITZ	4.430	2.009	CM5009138 X 1		6 28309 27558 7

NEW MERCURY™ ANODE KITS



	PID	LB	KG	Contains	Fits	UPC
Al	CM8M0107548KITA	1.54	0.70	CM8M0057772 x 1 CM826134 x 2 CM762145 x 1	MERCURY 8M0107548	6 28309 25580 0
Mg	CM8M0107548KITM	1.14	0.52			6 28309 25584 8
Zn	CM8M0107548KITZ	3.42	1.55			6 28309 25576 3



	PID	LB	KG	Contains	Fits	UPC
Al	CM8M0116590KITA	1.85	0.84	CM826134 x 2 CM762145 x 1 CM892227 x 2 CM8M0012083 x 1 CM8M0001734 x 1	MERCURY VERADO MMP	6 28309 25601 2
Mg	CM8M0116590KITM	1.45	0.66			6 28309 25603 6
Zn	CM8M0116590KITZ	3.66	1.66			6 28309 25599 2

NEW SUZUKI™ ANODE KIT



	PID	LB	KG	Contains	Fits	UPC
Al	CMSZ150350KITA	0.346	0.47	CM3C7602181A0 X 1 CM5532187J00 X 8 CM5532095310 X 3	Suzuki 150-350 HP	6 28309 27228 9
Mg	CMSZ150350KITM	0.763	0.346			6 28309 27229 6
Zn	CMSZ150350KITZ	2.117	0.96			6 28309 27227 2

INTRODUCING NEW PRODUCTS

Choose
Aluminum

Al premium
SALT AND BRACKISH WATER

Anodes for
salt and brackish
water and
Magnesium

Mg fresh
FRESH WATER ONLY

for freshwater.

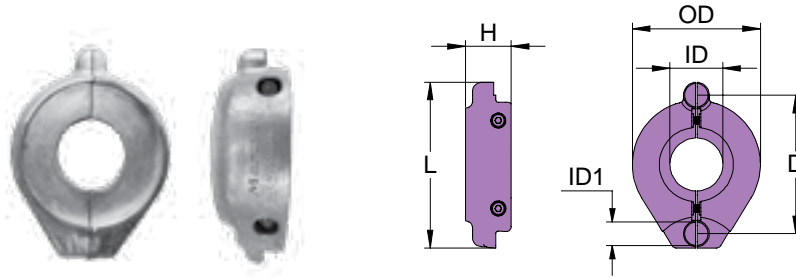

NEW VOLVO PENTA™ ANODE

	PID	LB	KG		L	H	D	ID	ID1	OD	UPC
Zn	CM22651246Z	3.213	1.457	mm	141.1	39	118	45	20	109	 6 28309 27309 5
				in	5.56	1.54	4.65	1.77	0.79	4.29	



NEW VOLVO PENTA™ ANODE KIT



	PID	LB	KG	Contains	Fits	UPC
Al	CM872793KITA	0.2	0.09	CM872793 X 2	Fits Volvo Penta 290, 290DP, XDP & DPX	 6 28309 18957 0
Mg	CM872793KITM	0.12	0.054			 6 28309 18958 7
Zn	CM872793KITZ	0.48	0.22			 6 28309 18959 4

Martyr®
INTRODUCING NEW PRODUCTS

PLEASURECRAFT

SHAFT & RUDDER

A N O D E S

Choose
Aluminum

Al premium
SALT AND BRACKISH WATER ◆

anodes for
salt and brackish
water and
Magnesium

Mg fresh
FRESH WATER ONLY ◆

for freshwater.

STREAMLINED SHAFT ANODES / imperial

Easy installation underwater.

Bolt retaining washers prevent the anode from falling off. Choose from two of our stainless steel hardware options:



Allen head w/ lock washer & bolt retaining washer



Slotted head w/ lock washer & bolt retaining washer (add S to the PID)

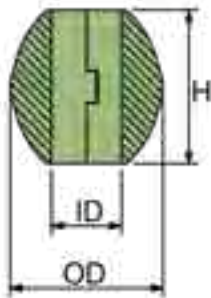

CMX00-CMX09

- Interlocking halves

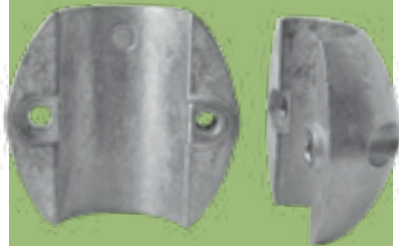

- Full shaft contact (100% CIRCULAR RADIUS)
- Extra alloy around fastener

	PID	LB	KG		H	OD	ID	UPC
Al	CMX00A	0.126	0.098	mm	50	42	12	6 28309 24256 5
Mg	CMX00M	0.145	0.066					6 28309 18277 9
Zn	CMX00	0.525	0.238	in	1.95	1.64	0.5	6 28309 12220 1
Al	CMX01AL	0.31	0.14	mm	51	52	19	6 28309 12752 7
Mg	CMX01M	0.22	0.10					6 28309 12771 8
Zn	CMX01	0.85	0.38	in	2	2.04	0.75	6 28309 10365 1
Al	CMX018125AL	0.31	0.14	mm	50.8	51.8	20.63	6 28309 12751 0
Zn	CMX018125	0.75	0.34	in	2	2.04	0.8125	6 28309 12350 5
Al	CMX02AL	0.34	0.15	mm	53	54	22.22	6 28309 12753 4
Mg	CMX02M	0.25	0.11					6 28309 12772 5
Zn	CMX02	0.95	0.43	in	2.08	2.12	0.875	6 28309 10366 8
Al	CMX03AL	0.36	0.16	mm	55	55	25	6 28309 12626 1
Mg	CMX03M	0.25	0.11					6 28309 11534 0
Zn	CMX03	1	0.45	in	2.15	2.16	1	6 28309 10367 5
Al	CMX04AL	0.43	0.19	mm	57	60	28.57	6 28309 12755 8
Mg	CMX04M	0.3	0.13					6 28309 12773 2
Zn	CMX04	1.16	0.526	in	2.25	2.36	1.125	6 28309 10368 2
Al	CMX05AL	0.46	0.208	mm	60	61	32	6 28309 12756 5
Mg	CMX05M	0.3	0.13					6 28309 11535 7
Zn	CMX05	1.18	0.535	in	2.35	2.42	1.25	6 28309 10369 9
Al	CMX05AAL	0.71	0.32	mm	62	68	32	6 28309 24257 2
Mg	CMX05AM	0.47	0.21					6 28309 24386 9
Zn	CMX05A	1.75	0.79	in	2.45	2.68	1.25	6 28309 10370 5
Al	CMX06AL	0.58	0.263	mm	60	67	34.92	6 28309 12757 2
Mg	CMX06M	0.38	0.17					6 28309 12774 9
Zn	CMX06	1.50	0.680	in	2.35	2.66	1.375	6 28309 10371 2
Zn	CMX0625	0.70	0.32	mm	50.8	48.76	15.87	6 28309 15714 2
				in	2	1.92	0.625	
Al	CMX07AL	0.66	0.299	mm	63	70	38	6 28309 12758 9
Mg	CMX07M	0.42	0.19					6 28309 12775 6
Zn	CMX07	1.70	0.771	in	2.5	2.78	1.5	6 28309 10372 9
Al	CMX08AL	0.95	0.43	mm	73	82	44	6 28309 12759 6
Mg	CMX08M	0.64	0.29					6 28309 12776 3
Zn	CMX08	2.4	1.09	in	2.75	3.25	1.75	6 28309 10373 6
Al	CMX09AL	1.17	0.53	mm	73	82	51	6 28309 12760 2
Mg	CMX09M	0.80	0.36					6 28309 12777 0
Zn	CMX09	2.97	1.347	in	2.9	3.6	2	6 28309 10374 3

SHAFT & RUDDER ANODES

Choose
Aluminum

Al premium
SALT AND BRACKISH WATER

Anodes for
salt and brackish
water and
Magnesium

Mg fresh
FRESH WATER ONLY
for freshwater.

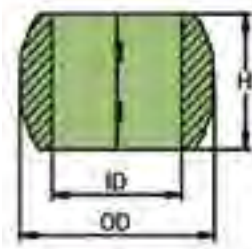

CMX10-CMX21

STREAMLINED SHAFT ANODES / imperial

PID		LB	KG		H	OD	ID	UPC
Al	CMX10AL	2.464	1.117	mm	95	106.1	57	6 28309 12761 9
Mg	CMX10M	1.608	0.729	in	3.75	4.18	2.25	6 28309 22963 4
Zn	CMX10	6.214	2.818					6 28309 10375 0
Al	CMX11AL	2.142	0.971					mm
Mg	CMX11M	1.404	0.637	in	3.75	4.18	2.5	6 28309 19129 0
Zn	CMX11	5.382	2.441					6 28309 10376 7
Al	CMX12AL	2.996	1.359					mm
Mg	CMX12M	1.964	0.891	in	3.625	4.8	2.75	6 28309 24387 6
Zn	CMX12	7.539	3.420					6 28309 10377 4
Al	CMX13AL	2.665	1.209					mm
Mg	CMX13M	1.752	0.795	in	3.625	4.8	3	6 28309 24388 3
Zn	CMX13	6.673	3.027					6 28309 10378 1
Al	CMX14A	2.87	1.30					mm
Mg	CMX14M	1.88	0.86	in	4.17	4.8	3.25	6 28309 23835 3
Zn	CMX14Z	7.21	3.27					6 28309 23836 0
Al	CMX15AL	3.642	1.652					mm
Mg	CMX15M	2.372	1.076	in	3.78	5.55	3.5	6 28309 24389 0
Zn	CMX15	9.211	4.178					6 28309 12232 4
Al	CMX17AL	3.51	1.59					mm
Mg	CMX17M	2.28	1.03	in	3.5	6	4.005	6 28309 24390 6
Zn	CMX17	8.91	4.04					6 28309 12223 2
Al	CMX18AL	4.859	2.204					mm
Mg	CMX18M	3.139	1.424	in	3.5	6.75	4.5	6 28309 24391 3
Zn	CMX18	12.420	5.634					6 28309 12793 0
Al	CMX19AL	3.648	1.655					mm
Mg	CMX19M	2.369	1.075	in	3.5	6.75	5	6 28309 24392 0
Zn	CMX19	9.270	4.205					6 28309 12794 7
Al	CMX20AL	6.230	2.826					mm
Mg	CMX20M	4.012	1.820	in	3.5	7.8	5.5	6 28309 23838 4
Zn	CMX20	15.957	7.238					6 28309 12795 4

Martyr
SHAFT & RUDDER ANODES

The world's best shaft anode design:

- Fit & longevity
- Easy installation underwater: bolt retaining washers prevent the anode from falling off

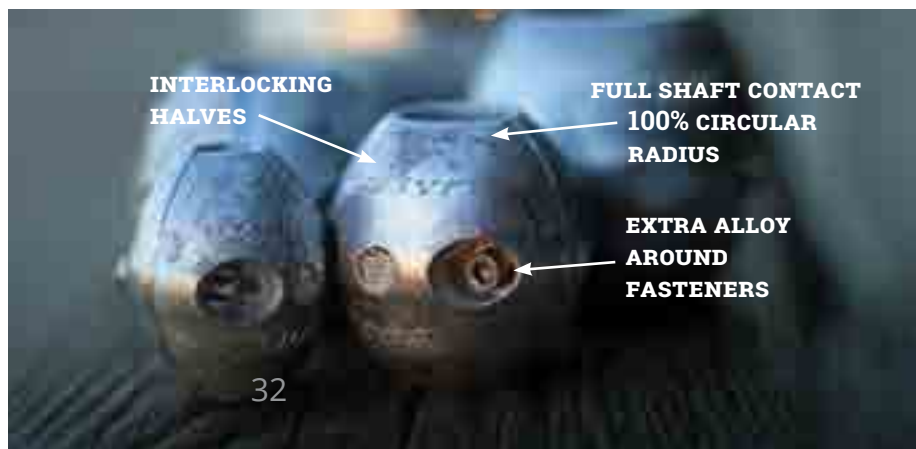

STREAMLINED SHAFT ANODES / imperial

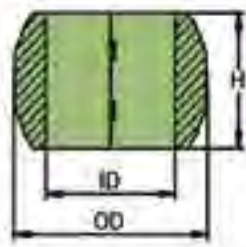

	PID	LB	KG		H	OD	ID	UPC
Al	CMX21AL	4.80	2.18	mm	89	198	152	6 28309 17582 5
Mg	CMX21M	3.10	1.40					6 28309 24393 7
Zn	CMX21	12.00	5.44	in	3.5	7.8	6	6 28309 12796 1

STREAMLINED SHAFT ANODES / metric

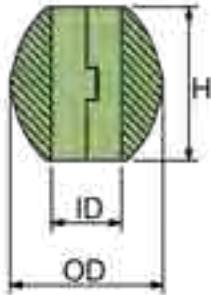

CMX00-CMX09

	PID	LB	KG		H	OD	ID	UPC
Al	CMXM20A	0.30	0.13	mm	48	51.2	20	6 28309 23863 6
Mg	CMXM20M	0.20	0.09					6 28309 23864 3
Zn	CMXM20Z	0.73	0.33	in	1.89	2.02	0.79	6 28309 23862 9
Al	CMX22A	0.279	0.127	mm	48	51.2	22	6 28309 23840 7
Mg	CMX22M	0.187	0.085					6 28309 23841 4
Zn	CMX22Z	0.685	0.311	in	1.89	2.01	0.86	6 28309 23842 1
Al	CMX25AL	0.480	0.217	mm	55	61	25	6 28309 12765 7
Mg	CMX25M	0.312	0.141					6 28309 24394 4
Zn	CMX25	1.216	0.551	in	2.17	2.40	1	6 28309 10379 8
Al	CMX28AL	0.51	0.23	mm	56	61	28	6 28309 23843 8
Mg	CMX28M	0.33	0.15					6 28309 23844 5
Zn	CMX28	1.28	0.58	in	2.20	2.40	1.10	6 28309 23845 2
Al	CMX30AL	0.486	0.220	mm	61	61	30	6 28309 12766 4
Mg	CMX30M	0.316	0.143					6 28309 12778 7
Zn	CMX30	1.228	0.557	in	2.40	2.40	1.18	6 28309 10380 4
Al	CMX34AL	0.68	0.31	mm	65	70	34	6 28309 21521 7
Mg	CMX34M	0.44	0.20					6 28309 21522 4
Zn	CMX34	1.73	0.79	in	2.60	2.75	1.34	6 28309 22962 7
Al	CMX35AL	0.630	0.285	mm	65	70	35	6 28309 12767 1
Mg	CMX35M	0.410	0.186					6 28309 12779 4
Zn	CMX35	1.610	0.730	in	2.62	2.75	1.38	6 28309 10381 1
Al	CMX40AL	1.222	0.554	mm	73	84	40	6 28309 12768 8
Mg	CMX40M	0.784	0.355					6 28309 12780 0
Zn	CMX40	3.152	1.429	in	2.87	3.30	1.57	6 28309 10382 8
Al	CMX45AL	1.082	0.490	mm	73	84	45	6 28309 12769 5
Mg	CMX45M	0.694	0.314					6 28309 12781 7
Zn	CMX45	2.782	1.262	in	2.87	3.30	1.77	6 28309 11530 2
Al	CMX50AL	0.924	0.419	mm	73	84	50	6 28309 12770 1
Mg	CMX50M	0.594	0.269					6 28309 12782 4
Zn	CMX50	2.370	1.075	in	2.87	3.30	2	6 28309 10383 5
Al	CMX55AL	2.41	1.09	mm	90	105	55	6 28309 19282 2
Mg	CMX55M	1.59	0.72					6 28309 22964 1
Zn	CMX55	6.03	2.73	in	3.54	4.13	2.17	6 28309 12821 0
Al	CMX60A	2.342	1.062	mm	95.25	106.2	60	6 28309 19335 5
Mg	CMX60M	1.536	0.696					6 28309 19343 0
Zn	CMX60	5.882	2.668	in	3.75	4.18	2.36	6 28309 12580 6

SHAFT & RUDDER ANODES

- Interlocking halves



- Full shaft contact (100% CIRCULAR RADIUS)
- Extra alloy around fastener

Protect your boat, respect our waters.

STREAMLINED SHAFT ANODES / metric

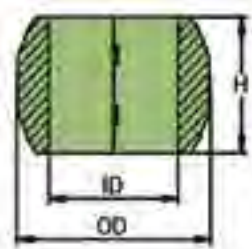

cmx55-cmx125

Martyr®

SHAFT & RUDDER ANODES

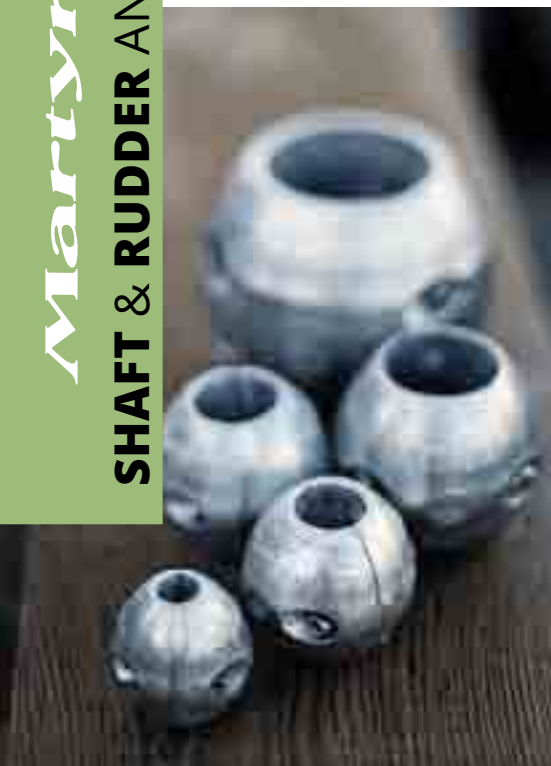

PID		LB	KG		H	OD	ID	UPC
Al	CMX65A	3.13	1.42	mm	90	120	65	6 28309 19336 2
Mg	CMX65M	2.04	0.92					6 28309 19344 7
Zn	CMX65	7.89	3.58	in	3.54	4.72	2.56	6 28309 12822 7
Al	CMX70A	3.046	1.382	mm	100	120	70	6 28309 19337 9
Mg	CMX70M	1.993	0.904					6 28309 19345 4
Zn	CMX70	7.681	3.484	in	3.94	4.72	2.76	6 28309 12823 4
Al	CMX75A	3.5	1.58	mm	100	125	75	6 28309 19338 6
Mg	CMX75M	2.3	1.04					6 28309 19346 1
Zn	CMX75	8.9	4.03	in	3.94	4.92	2.95	6 28309 12824 1
Al	CMX80A	3.65	1.65	mm	100	130	80	6 28309 19340 9
Mg	CMX80M	2.41	1.09					6 28309 19347 8
Zn	CMX80	9.18	4.16	in	3.94	5.12	3.15	6 28309 12825 8
Al	CMX85A	2.66	1.21	mm	106	122	85	6 28309 19339 3
Mg	CMX85M	1.74	0.79					6 28309 19348 5
Zn	CMX85Z	6.70	3.04	in	4.17	4.80	3.34	6 28309 23846 9
Al	CMX90A	4.32	1.96	mm	110	144	90	6 28309 19341 6
Mg	CMX90M	2.84	1.29					6 28309 19349 2
Zn	CMX90	10.84	4.92	in	4.33	5.67	3.54	6 28309 12827 2
Al	CMX95A	3.884	1.762	mm	110	144	95	6 28309 19342 3
Mg	CMX95M	2.557	1.160					6 28309 19350 8
Zn	CMX95Z	9.709	4.404	in	4.33	5.67	3.74	6 28309 23847 6
Al	CMX100AL	4.47	2.03	mm	100	150	100	6 28309 19243 3
Mg	CMX100M	2.92	1.32					6 28309 19244 0
Zn	CMX100	11.3	5.12	in	3.94	5.83	3.93	6 28309 12829 6
Al	CMX110A	11.15	5.06	mm	160	180	110	6 28309 23819 3
Mg	CMX110M	7.14	3.24					6 28309 23820 9
Zn	CMX110Z	28.79	13.06	in	6.30	7.09	4.33	6 28309 12831 9
Al	CMX115A	10.67	4.84	mm	160	180	115	6 28309 23822 3
Mg	CMX115M	6.83	3.10					6 28309 23823 0
Zn	CMX115Z	27.47	12.46	in	6.30	7.09	4.53	6 28309 12832 6
Al	CMX120A	9.356	4.244	mm	160	180	120	6 28309 23825 4
Mg	CMX120M	6.005	2.724					6 28309 23826 1
Zn	CMX120Z	24.048	10.908	in	6.30	7.09	4.72	6 28309 23827 8
Al	CMX123A	8.871	4.024	mm	160	180	123	6 28309 23828 5
Mg	CMX123M	5.718	2.594					6 28309 23829 2
Zn	CMX123Z	22.804	10.344	in	6.30	7.09	4.84	6 28309 23830 8
Al	CMX125A	8.430	3.824	mm	160	180	125	6 28309 23831 5
Mg	CMX125M	5.474	2.483					6 28309 23832 2
Zn	CMX125Z	21.832	9.903	in	6.30	7.09	4.92	6 28309 23833 9

**NEW
PRODUCT**

HEAVY DUTY STREAMLINED SHAFT ANODES / metric

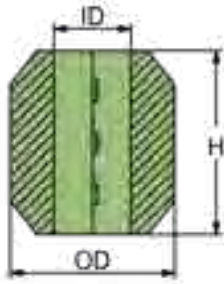

The world's best shaft anode design:

- Easy installation underwater: bolt retaining washers prevent the anode from falling off
- Interlocking halves
- Fit & longevity

	PID	LB	KG		H	OD	ID	UPC
Al	CMX09HDA	3.99	1.81	mm	120	106	51	6 28309 26582 3
Mg	CMX09HDM	2.58	1.17					6 28309 26593 9
Zn	CMX09HDZ	10.14	4.60	in	4.72	4.17	2.01	6 28309 26571 7
Al	CMX10HDA	3.75	1.70	mm	120	107.5	57	6 28309 26583 0
Mg	CMX10HDM	2.42	1.10					6 28309 26594 6
Zn	CMX10HDZ	9.48	4.30	in	4.72	4.23	2.2	6 28309 26572 4
Al	CMX11HDA	3.42	1.55	mm	120	107.5	64	6 28309 26584 7
Mg	CMX11HDM	2.22	1.01					6 28309 26595 3
Zn	CMX11HDZ	8.64	3.92	in	4.72	4.23	2.52	6 28309 26573 1
Al	CMX12HDA	4.83	2.19	mm	130	122.8	70	6 28309 26585 4
Mg	CMX12HDM	3.11	1.41					6 28309 26596 0
Zn	CMX12HDZ	12.34	5.6	in	5.12	4.83	2.75	6 28309 26574 8
Al	CMX13HDA	4.32	1.96	mm	130	122.8	76	6 28309 26586 1
Mg	CMX13HDM	2.80	1.27					6 28309 26597 7
Zn	CMX13HDZ	11.04	5.01	in	5.12	4.83	2.99	6 28309 26575 5
Al	CMX16HDA	15.83	7.18	mm	188	174.3	95	6 28309 26589 2
Mg	CMX16HDM	10.12	4.59					6 28309 26600 4
Zn	CMX16HDZ	40.86	18.53	in	7.40	6.86	3.75	6 28309 26576 8
Al	CMX17HDA	14.75	6.69	mm	188	174.3	102	6 28309 26590 0
Mg	CMX17HDM	9.44	4.28					6 28309 26601 1
Zn	CMX17HDZ	38.04	17.25	in	7.40	6.86	4	6 28309 26579 3
Al	CMX17LHDA	13.58	6.16	mm	188	174.3	108	6 28309 26591 5
Mg	CMX17LHDM	8.71	3.95					6 28309 26602 0
Zn	CMX17LHDZ	35.04	15.89	in	7.40	6.86	4.25	6 28309 26580 8
Al	CMX18HDA	12.37	5.61	mm	188	174.3	114	6 28309 26582 2
Mg	CMX18HDM	7.94	3.6					6 28309 26603 5
Zn	CMX18HDZ	31.84	14.44	in	7.40	6.86	4.5	6 28309 26581 4

CLAMP SHAFT ANODES / imperial

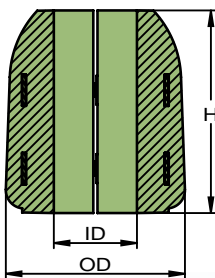

	PID	LB	KG		H	OD	ID	UPC
Al	CMXC01A	0.677	0.307	mm	65	56	19	6 28309 18009 6
Mg	CMXC01M	0.456	0.207					6 28309 24398 2
Zn	CMXC01Z	1.647	0.747	in	2.54	2.19	0.75	6 28309 17485 9
Al	CMXC02A	0.646	0.293	mm	65	56	22	6 28309 18010 2
Mg	CMXC02M	0.434	0.197					6 28309 24399 9
Zn	CMXC02Z	1.567	0.711	in	2.54	2.19	0.87	6 28309 17488 0
Al	CMXC03A	0.606	0.275	mm	65	56	25	6 28309 18011 9
Mg	CMXC03M	0.408	0.185					6 28309 19600 4
Zn	CMXC03Z	1.461	0.663	in	2.54	2.19	1	6 28309 17491 0
Al	CMXC04A	0.553	0.251	mm	65	56	29	6 28309 18012 6
Mg	CMXC04M	0.377	0.171					6 28309 24400 2
Zn	CMXC04Z	1.325	0.601	in	2.54	2.19	1.12	6 28309 17494 1
Al	CMXC05A	1.113	0.505	mm	78	70	32	6 28309 18013 3
Mg	CMXC05M	0.765	0.347					6 28309 24401 9
Zn	CMXC05Z	2.634	1.195	in	3.05	2.7	1.25	6 28309 17497 2

SHAFT & RUDDER ANODES

Choose
Aluminum

Al premium
SALT AND BRACKISH WATER

Anodes for
salt and brackish
water and
Magnesium

Mg fresh
FRESH WATER ONLY
for freshwater.

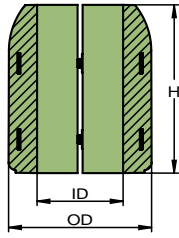

Comes with slotted head
w/lock washer & bolt
retaining washer.

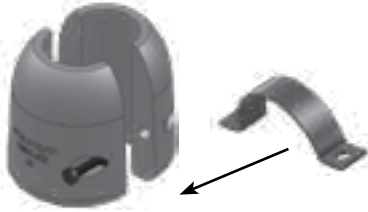

Internal steel clamp insert holds
the anode completely tight
to the shaft



**Engineered to ensure
complete shaft contact:**

- Clamp insert ensures tight fit to shaft for duration of life
- Stainless steel hardware and lock washers included
- Bolt retaining washers prevent the anode from falling off – easy installation underwater

CLAMP SHAFT ANODES / imperial

PID		LB	KG		H	OD	ID	UPC	
Al	CMXC06A	1.038	0.471	mm	78	68.5	35	6	28309 18014 0
Mg	CMXC06M	0.716	0.325					6	28309 24402 6
Zn	CMXC06Z	2.440	1.107	in	3.05	2.697	1.37	6	28309 17500 9
Al	CMXC07A	1.003	0.455	mm	78	68.5	38	6	28309 18015 7
Mg	CMXC07M	0.694	0.315					6	28309 24403 3
Zn	CMXC07Z	2.352	1.067	in	3.05	2.697	1.5	6	28309 17503 0
Al	CMXC08A	2.21	1	mm	100	85	45	6	28309 18016 4
Mg	CMXC08M	1.47	0.66					6	28309 24404 0
Zn	CMXC08Z	5.48	2.49	in	3.92	3.33	1.75	6	28309 17506 1
Al	CMXC09A	1.87	0.85	mm	100	85	51	6	28309 18017 1
Mg	CMXC09M	1.25	0.57					6	28309 24405 7
Zn	CMXC09Z	4.57	2.07	in	3.92	3.33	2	6	28309 17509 2

CLAMP SHAFT ANODES / metric

PID		LB	KG		H	OD	ID	UPC	
Al	CMXC25A	0.606	0.275	mm	65	56	25	6	28309 18018 8
Mg	CMXC25M	0.412	0.187					6	28309 24406 4
Zn	CMXC25Z	1.461	0.663	in	2.5	2.2	1	6	28309 17512 2
Al	CMXC30A	0.529	0.240	mm	65	56	30	6	28309 18019 5
Mg	CMXC30M	0.357	0.162					6	28309 24407 1
Zn	CMXC30Z	1.269	0.576	in	2.5	2.2	1.19	6	28309 17515 3
Al	CMXC35A	1.03	0.47	mm	78	69	35	6	28309 18020 1
Mg	CMXC35M	0.70	0.32					6	28309 24408 8
Zn	CMXC35Z	2.42	1.10	in	3	2.74	1.37	6	28309 17518 4
Al	CMXC40A	0.950	0.431	mm	78	69	40	6	28309 18021 8
Mg	CMXC40M	0.663	0.301					6	28309 24409 5
Zn	CMXC40Z	2.215	1.005	in	3	2.74	1.58	6	28309 17521 4
Al	CMXC45A	2.18	0.99	mm	100	85	45	6	28309 18022 5
Mg	CMXC45M	1.38	0.62					6	28309 24410 1
Zn	CMXC45Z	5.42	2.46	in	4	3.33	1.75	6	28309 17524 5
Al	CMXC50A	1.986	0.901	mm	100	85	50	6	28309 18023 2
Mg	CMXC50M	1.325	0.601					6	28309 24411 8
Zn	CMXC50Z	4.883	2.215	in	4	3.33	2	6	28309 17527 6
Al	CMXC60A	1.492	0.677	mm	100	85	60	6	28309 18024 9
Mg	CMXC60M	1.016	0.461					6	28309 24412 5
Zn	CMXC60Z	3.604	1.635	in	4	3.33	2.33	6	28309 17530 6
Al	CMXC70A	2.64	1.19	mm	96	113	70	6	28309 18025 6
Mg	CMXC70M	1.61	0.73					6	28309 24413 2
Zn	CMXC70Z	6.54	2.96	in	3.75	4.43	2.75	6	28309 17533 7

LIMITED CLEARANCE SHAFT ANODES / imperial

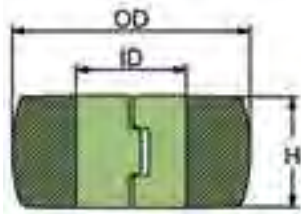

Easy installation underwater:

Bolt retaining washers prevent the anode from falling off. Choose from two of our stainless steel hardware options:



Allen head w/ lock washer & bolt retaining washer



Slotted head w/ lock washer & bolt retaining washer (add S to the PID)

- Full shaft contact: 100% circular radius
- Interlocking halves
- Extra alloy around fastener



	PID	LB	KG		H	OD	ID	UPC
Al	CMC01AL	0.319	0.145	mm	25.4	59.94	19.05	6 28309 19154 2
Mg	CMC01M	0.211	0.096					6 28309 24302 9
Zn	CMC01	0.793	0.36	in	1	2.36	0.75	6 28309 10303 3
Al	CMC02AL	0.302	0.137	mm	25.4	59.94	22.22	6 28309 19155 9
Mg	CMC02M	0.2	0.091					6 28309 24303 6
Zn	CMC02	0.749	0.34	in	1	2.36	0.875	6 28309 10304 0
Al	CMC03AL	0.525	0.238	mm	31.75	68.58	25.4	6 28309 17058 5
Mg	CMC03M	0.355	0.161					6 28309 15991 7
Zn	CMC03	1.272	0.577	in	1.25	2.7	1	6 28309 10305 7
Al	CMC04AL	0.509	0.231	mm	31.75	68.58	28.57	6 28309 19156 6
Mg	CMC04M	0.344	0.156					6 28309 24304 3
Zn	CMC04	1.232	0.559	in	1.25	2.7	1.125	6 28309 10306 4
Al	CMC05AL	0.475	0.215	mm	31.75	68.58	31.75	6 28309 17059 2
Mg	CMC05M	0.325	0.147					6 28309 15992 4
Zn	CMC05	1.14	0.517	in	1.25	2.7	1.25	6 28309 10307 1
Al	CMC06AL	0.699	0.317	mm	31.75	81.02	34.92	6 28309 17060 8
Mg	CMC06M	0.467	0.212					6 28309 15993 1
Zn	CMC06	1.713	0.777	in	1.25	3.19	1.375	6 28309 10308 8
Al	CMC07AL	0.694	0.315	mm	31.75	81.02	38.1	6 28309 19157 3
Mg	CMC07M	0.461	0.209					6 28309 22977 1
Zn	CMC07	1.713	0.777	in	1.25	3.19	1.5	6 28309 10309 5
Al	CMC08AL	1.036	0.470	mm	34.92	93.98	44.45	6 28309 19158 0
Mg	CMC08M	0.679	0.308					6 28309 24305 0
Zn	CMC08Z	2.606	1.182	in	1.375	3.7	1.75	6 28309 10310 1
Al	CMC09AL	0.875	0.397	mm	34.92	93.98	50.8	6 28309 10312 5
Mg	CMC09M	0.579	0.263					6 28309 24307 4
Zn	CMC09	2.176	0.987	in	1.375	3.7	2	6 28309 10311 8
Al	CMC09AAL	0.767	0.348	mm	34.92	93.98	57.15	6 28309 19160 3
Mg	CMC09AM	0.507	0.23					6 28309 24306 7
Zn	CMC09A	1.9	0.862	in	1.375	3.7	2.25	6 28309 19159 7
Al	CMC12AL	2.16	0.98	mm	38.1	132.08	63.5	6 28309 10314 9
Mg	CMC12M	1.402	0.636					6 28309 24311 1
Zn	CMC12	5.489	2.49	in	1.5	5.2	2.5	6 28309 10313 2
Al	CMC12AAL	2.015	0.914	mm	38.1	132.08	69.85	6 28309 19162 7
Mg	CMC12AM	1.289	0.585					6 28309 24310 4
Zn	CMC12A	5.084	2.306	in	1.5	5.2	2.75	6 28309 19161 0
Al	CMC13AL	1.852	0.84	mm	38.1	132.08	76.2	6 28309 19163 4
Mg	CMC13M	1.204	0.546					6 28309 24312 8
Zn	CMC13	4.691	2.128	in	1.5	5.2	3	6 28309 10315 6
Al	CMC14AL	3.393	1.539	mm	38.1	172.72	88.9	6 28309 19164 1
Mg	CMC14M	2.193	0.995					6 28309 24313 5
Zn	CMC14	8.659	3.928	in	1.5	6.8	3.5	6 28309 10316 3

SHAFT & RUDDER ANODES



LIMITED CLEARANCE SHAFT ANODES / imperial

	PID	LB	KG		H	OD	ID	UPC
Al	CMC15AL	2.98	1.354	mm	38.1	172.72	101.6	6 28309 19165 8
Mg	CMC15M	1.93	0.877					6 28309 24314 2
Zn	CMC15	7.59	3.445	in	1.5	6.8	4	6 28309 10317 0

LIMITED CLEARANCE SHAFT ANODES / metric

	PID	LB	KG		H	OD	ID	UPC
Al	CMC20AL	0.328	0.149	mm	25.4	60	20	6 28309 18987 7
Mg	CMC20M	0.216	0.098					6 28309 18997 6
Zn	CMC20	0.818	0.371	in	1	2.36	0.79	6 28309 11533 3
Al	CMC25AL	0.529	0.240	mm	31.75	68.7	25	6 28309 18989 1
Mg	CMC25M	0.357	0.162					6 28309 18999 0
Zn	CMC25	1.285	0.583	in	1.25	2.7	0.98	6 28309 11524 1
Al	CMC30AL	0.496	0.225	mm	31.75	68.7	30	6 28309 18988 4
Mg	CMC30M	0.337	0.153					6 28309 18998 3
Zn	CMC30	1.199	0.544	in	1.25	2.7	1.18	6 28309 11525 8
Al	CMC35AL	0.696	0.316	mm	31.75	81	35	6 28309 19166 5
Mg	CMC35M	0.465	0.211					6 28309 24315 9
Zn	CMC35	1.711	0.776	in	1.25	3.19	1.37	6 28309 11526 5
Al	CMC40AL	0.672	0.305	mm	31.75	81	40	6 28309 19167 2
Mg	CMC40M	0.447	0.203					6 28309 21038 0
Zn	CMC40	1.655	0.751	in	1.25	3.19	1.57	6 28309 11527 2
Al	CMC45A	0.985	0.447	mm	34.925	94	45	6 28309 24192 6
Mg	CMC45M	0.646	0.293					6 28309 24317 3
Zn	CMC45	2.475	1.123	in	1.375	3.7	1.77	6 28309 11528 9
Al	CMC50A	0.908	0.412	mm	34.925	94	50	6 28309 24193 3
Mg	CMC50M	0.597	0.271					6 28309 24319 7
Zn	CMC50	2.271	1.030	in	1.375	3.7	1.97	6 28309 11529 6
Al	CMC55A	1.23	0.56	mm	29	114	55	6 28309 23577 2
Mg	CMC55M	0.81	0.37					6 28309 23578 9
Zn	CMC55Z	3.12	1.42	in	1.14	4.49	2.17	6 28309 23579 6
Al	CMC60A	1.389	0.630	mm	27.5	123.5	60	6 28309 24194 0
Mg	CMC60M	0.924	0.419					6 28309 24320 3
Zn	CMC60	3.439	1.560	in	1.08	4.86	2.36	6 28309 12834 0
Al	CMC65A	1.547	0.702	mm	29	130	65	6 28309 23580 2
Mg	CMC65M	0.983	0.446					6 28309 23581 9
Zn	CMC65Z	3.805	1.726	in	1.14	5.118	2.56	6 28309 23582 6
Al	CMC70A	1.501	0.681	mm	27.5	132	70	6 28309 24197 1
Mg	CMC70M	0.994	0.451					6 28309 24323 4
Zn	CMC70	3.728	1.691	in	1.08	5.19	2.75	6 28309 12836 4
Al	CMC75A	1.662	0.754	mm	27.5	138	75	6 28309 24198 8
Mg	CMC75M	1.095	0.497					6 28309 24324 1
Zn	CMC75	4.149	1.882	in	1.08	5.43	2.95	6 28309 12837 1

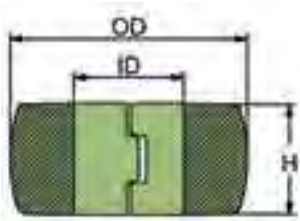

Martyr®
SHAFT & RUDDER ANODES

Easy installation underwater:

Bolt retaining washers prevent the anode from falling off. Choose from two of our stainless steel hardware options:



Allen head w/ lock washer & bolt retaining washer

Slotted head w/ lock washer & bolt retaining washer (add S to the PID)

LIMITED CLEARANCE SHAFT ANODES / metric

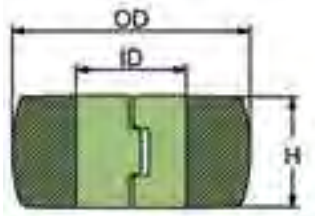

	PID	LB	KG		H	OD	ID	UPC
Al	CMC80A	1.666	0.756	mm	27.5	143	80	6 28309 24199 5
Mg	CMC80M	1.08	0.49					6 28309 24325 8
Zn	CMC80	4.16	1.887	in	1.08	5.63	3.15	6 28309 12838 8
Al	CMC85A	2.711	1.230	mm	35	160	85	6 28309 23583 3
Mg	CMC85M	1.763	0.800					6 28309 23584 0
Zn	CMC85Z	6.887	3.124	in	1.37	6.29	3.35	6 28309 23585 7
Al	CMC90A	3.554	1.612	mm	38	174	90	6 28309 24200 8
Mg	CMC90M	2.293	1.04					6 28309 24326 5
Zn	CMC90	9.074	4.116	in	1.49	6.85	3.54	6 28309 12840 1
Al	CMC95A	3.637	1.650	mm	38	174	95	6 28309 23586 4
Mg	CMC95M	2.319	1.052					6 28309 23587 1
Zn	CMC95Z	9.180	4.164	in	1.49	6.85	3.74	6 28309 23588 8
Al	CMC100A	3.889	1.764	mm	38	184	100	6 28309 24190 2
Mg	CMC100M	2.506	1.137					6 28309 24308 1
Zn	CMC100	9.951	4.514	in	1.49	7.24	3.94	6 28309 12842 5
Al	CMC120A	5.758	2.612	mm	37.5	223	120	6 28309 24191 9
Mg	CMC120M	3.69	1.674					6 28309 24309 8
Zn	CMC120	14.929	6.772	in	1.47	8.78	4.72	6 28309 12846 3

EURO STYLE LIMITED CLEARANCE SHAFT ANODES

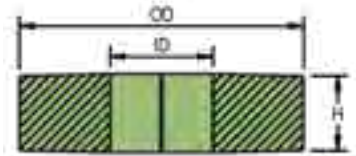

Thin euro style collar anodes.

Easy installation underwater. Bolt retaining washers prevent the anode from falling off.



Comes with allen head w/lock washer & bolt retaining washer

	PID	LB	KG		H	OD	ID	UPC
Al	CMC22EUROA	0.196	0.089	mm	15.5	60	22	6 28309 19459 8
Mg	CMC22EUROM	0.13	0.059					6 28309 21216 2
Zn	CMC22EURO	0.496	0.225	in	0.61	2.36	0.86	6 28309 16000 5
Al	CMC25EUROA	0.211	0.096	mm	15.5	60	25	6 28309 19460 4
Mg	CMC25EUROM	0.149	0.068					6 28309 21217 9
Zn	CMC25EURO	0.485	0.22	in	0.61	2.36	0.98	6 28309 16001 2
Al	CMC30EUROA	0.194	0.088	mm	15.5	60	30	6 28309 19461 1
Mg	CMC30EUROM	0.136	0.062					6 28309 21033 5
Zn	CMC30EURO	0.441	0.2	in	0.61	2.36	1.18	6 28309 16002 9
Al	CMC35EUROA	0.33	0.15	mm	17.6	74	35	6 28309 19462 8
Mg	CMC35EUROM	0.225	0.102					6 28309 21035 9
Zn	CMC35EURO	0.793	0.36	in	0.69	2.91	1.37	6 28309 16003 6
Al	CMC40EUROA	0.299	0.136	mm	17.6	74	40	6 28309 19463 5
Mg	CMC40EUROM	0.203	0.092					6 28309 21037 3
Zn	CMC40EURO	0.705	0.32	in	0.69	2.91	1.57	6 28309 16004 3
Al	CMC45EUROA	0.344	0.156	mm	18	82	45	6 28309 19464 2
Mg	CMC45EUROM	0.236	0.107					6 28309 24316 6
Zn	CMC45EURO	0.864	0.392	in	0.71	3.23	1.77	6 28309 16005 0
Al	CMC50EUROA	0.33	0.15	mm	18	82	50	6 28309 19465 9
Mg	CMC50EUROM	0.225	0.102					6 28309 24318 0
Zn	CMC50EURO	0.793	0.36	in	0.71	3.23	1.97	6 28309 16006 7

Choose
Aluminum

Al premium
SALT AND BRACKISH WATER

Anodes for
salt and brackish
water and
Magnesium

Mg fresh
FRESH WATER ONLY
for freshwater.

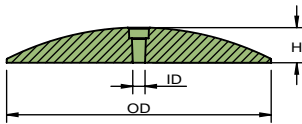

Martyr
SHAFT & RUDDER ANODES

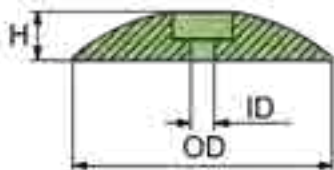

SOLD AS A SINGLE HALF

RUDDER/TRIM TAB ANODES

	PID	LB	KG		H	OD	ID	UPC
Al	CMR01AL	0.121	0.055	mm	6	47	5	6 28309 12783 1
Mg	CMR01M	0.081	0.037					6 28309 12787 9
Zn	CMR01	0.293	0.133	in	0.35	1.87	0.2	6 28309 10350 7
Al	CMR02AL	0.377	0.171	mm	12	71	7	6 28309 12784 8
Mg	CMR02M	0.249	0.113					6 28309 11536 4
Zn	CMR02	0.939	0.426	in	0.5	2.81	0.28	6 28309 10352 1
Al	CMR03AL	0.643	0.292	mm	12	95	9	6 28309 12785 5
Mg	CMR03M	0.425	0.193					6 28309 12788 6
Zn	CMR03	1.602	0.727	in	0.5	3.75	0.34	6 28309 10354 5
Al	CMR04AL	1.349	0.612	mm	16	127	9	6 28309 12786 2
Mg	CMR04M	0.875	0.397					6 28309 12791 6
Zn	CMR04	3.432	1.557	in	0.65	5	0.34	6 28309 10355 2
Al	CMR05AL	1.933	0.877	mm	22	130	9.5	6 28309 18272 4
Mg	CMR05M	1.250	0.567					6 28309 12792 3
Zn	CMR05	4.936	2.239	in	0.87	5.12	0.37	6 28309 10356 9
Al	CMR07AL	3.653	1.657	mm	23	175	8	6 28309 22976 4
Mg	CMR07M	2.484	1.127					6 28309 23317 4
Zn	CMR07	9.385	4.257	in	0.87	6.87	0.32	6 28309 10357 6

Rudder anodes are sold in pairs, with stainless steel bolt and nut.

- Easy installation underwater
- Bolt retaining washers prevent the anode from falling off

EURO STYLE RUDDER/TRIM TAB ANODES

	PID	LB	KG		H	OD	ID	UPC
Al	CMF50A	0.06	0.03	mm	11	50	7	6 28309 19263 1
Mg	CMF50M	0.04	0.02					6 28309 21190 5
Zn	CMF50Z	0.17	0.08	in	0.41	2	0.26	6 28309 17468 2
Al	CMF70A	0.156	0.071	mm	13	70	9	6 28309 19264 8
Mg	CMF70M	0.101	0.046					6 28309 21191 2
Zn	CMF70Z	0.399	0.181		0.5	2.75	0.35	6 28309 17470 5
Al	CMF90A	0.361	0.164	mm	17	90	9	6 28309 19265 5
Mg	CMF90M	0.231	0.105					6 28309 21192 9
Zn	CMF90Z	0.915	0.415	in	0.66	3.5	0.35	6 28309 17472 9
Al	CMF110A	0.568	0.258	mm	19	110	11	6 28309 19261 7
Mg	CMF110M	0.363	0.165					6 28309 21189 9
Zn	CMF110Z	1.439	0.653	in	0.75	4.33	0.42	6 28309 17462 0
Al	CMF125A	0.804	0.365	mm	21	125	11	6 28309 19262 4
Mg	CMF125M	0.509	0.231					6 28309 23234 4
Zn	CMF125Z	2.098	0.952	in	0.83	5	0.45	6 28309 17464 4

EURO STYLE RUDDER/TRIM TAB ANODES

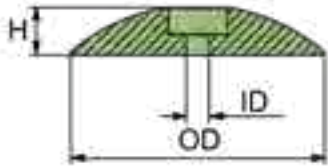

Rudder anodes are sold in pairs, with stainless steel bolt and nut.

- Easy installation underwater
- Bolt retaining washers prevent the anode from falling off



SOLD AS TWO HALVES, ASSEMBLED WITH A ZIP TIE

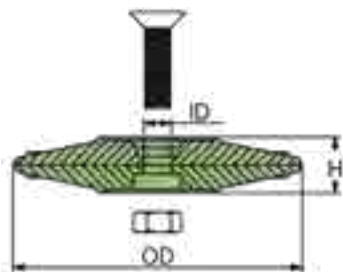
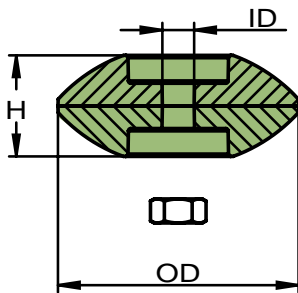

	PID	LB	KG		H	OD	ID	UPC
Al	CMF140A	1.300	0.590	mm	26	140	13	6 28309 21030 4
Mg	CMF140M	0.815	0.370					6 28309 23235 1
Zn	CMF140Z	3.395	1.540	in	1	5.5	0.5	6 28309 17466 8
Al	CMF190A	2.502	1.135	mm	29	190	11	6 28309 24206 0
Mg	CMF190M	1.587	0.720					6 28309 24332 6
Zn	CMF190Z	6.525	2.960	in	1.14	7.5	0.43	6 28309 24127 8

	PID	LB	KG		H	OD	ID	UPC
Al	CMF50CA	0.161	0.073	mm	22	50	7	6 28309 24672 3
Mg	CMF50CM	0.112	0.051					6 28309 24688 4
Zn	CMF50CZ	0.368	0.167	in	0.82	2	0.26	6 28309 24658 7
Al	CMF70CA	0.368	0.167	mm	26	70	9	6 28309 24673 0
Mg	CMF70CM	0.258	0.117					6 28309 24689 1
Zn	CMF70CZ	0.853	0.387	in	1.02	2 3/4	0.35	6 28309 24659 4
Al	CMF90CA	0.785	0.356	mm	34	90	9	6 28309 24674 7
Mg	CMF90CM	0.524	0.238					6 28309 24690 7
Zn	CMF90CZ	1.891	0.858	in	1.33	3 1/2	0.35	6 28309 24660 0
Al	CMF110CA	1.208	0.548	mm	38	110	11	6 28309 26004 0
Mg	CMF110CM	0.798	0.362					Please contact us
Zn	CMF110CZ	2.949	1.338	in	1.5	4 1/3	0.42	6 28309 24679 2
Al	CMF125CA	1.693	0.768	mm	42	125	11	6 28309 24666 2
Mg	CMF125CM	1.142	0.518					6 28309 24681 5
Zn	CMF125CZ	4.321	1.960	in	1.66	5	0.45	6 28309 24654 9
Al	CMF140CA	2.780	1.261	mm	52	140	13	6 28309 26005 7
Zn	CMF140CZ	6.969	3.161	in	2	5 1/2	0.5	6 28309 25981 5

SHAFT & RUDDER ANODES

SPANISH STYLE RUDDER/TRIM TAB ANODES

	PID	LB	KG		H	OD	ID	UPC
Al	CMF70SPA	0.211	0.096	mm	15	70	8.5	6 28309 23625 0
Mg	CMF70SPM	0.147	0.067					6 28309 23626 7
Zn	CMF70SPZ	0.494	0.224	in	0.59	2.75	0.33	6 28309 23627 4
Al	CMF90SPA	0.401	0.182	mm	17.4	90	8.5	6 28309 23628 1
Mg	CMF90SPM	0.267	0.121					6 28309 23629 8
Zn	CMF90SPZ	0.987	0.448	in	0.68	3.54	0.33	6 28309 23630 4
Al	CMF130SPA	0.941	0.427	mm	20	130	8.5	6 28309 23622 9
Mg	CMF130SPM	0.610	0.277					6 28309 23623 6
Zn	CMF130SPZ	2.40	1.088	in	0.78	5.12	0.33	6 28309 23624 3

Protect your boat, respect our waters.

PLEASURECRAFT

P R O P E L L E R

A N O D E S

PROPELLER NUT ANODES / incl. insert & hardware

PROP NUT COMPLETE

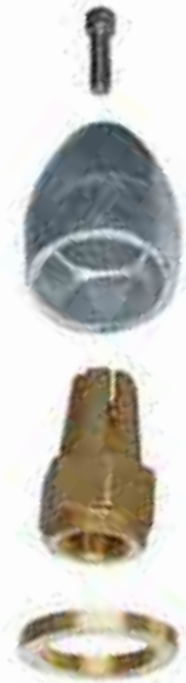
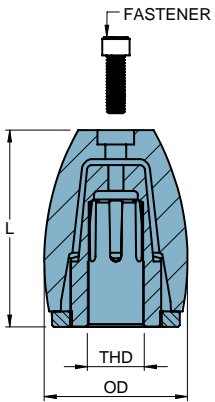

TYPE	PID	LB	KG		SHAFT	L	OD	THREAD	FASTER NER	UPC	
Al	A	CMPNAAC13	0.203	0.092	mm	19	38	32	1/2"-13 UNC	1/4- 20 x 1/2	6 28309 12078 8
Mg		CMPNAMC13	0.178	0.081							6 28309 11511 1
Zn		CMPNAZC13	0.339	0.154	in	0.75	1.5	1.25	6 28309 10824 3		
Al	B	CMPNBAC11	0.434	0.197	mm	22	56	41	5/8"-11 UNC	1/4- 20 x 1/2	6 28309 12349 9
Mg		CMPNBMC11	0.370	0.168							6 28309 11342 1
Zn		CMPNBZC11	0.756	0.343	in	0.87	2.2	1.65	6 28309 10828 1		
Al	C	CMPNCAC10	0.871	0.395	mm	25	74	48	3/4"-10 UNC	5/16- 18 x 1	6 28309 12211 9
Mg		CMPNCMC10	0.707	0.321							6 28309 11344 5
Zn		CMPNCZC10	1.558	0.707	in	1	2.9	2	6 28309 10831 1		
Al	C	CMPNCAF16	0.871	0.395	mm	29	74	48	3/4"-16 UNF	5/16- 18 x 1	6 28309 12373 4
Mg		CMPNCMF16	0.707	0.321							6 28309 11345 2
Zn		CMPNCZF16	1.558	0.707	in	1.12	2.9	2	6 28309 10832 8		
Al	D	CMPNDAC09	1.155	0.524	mm	32	78	54	7/8"-9 UNC	5/16- 18 x 1	6 28309 12212 6
Mg		CMPNDMC09	0.968	0.439							6 28309 11347 6
Zn		CMPNDZC09	2.178	0.988	in	1.25	3.06	2.3	6 28309 10835 9		
Al	D	CMPNDAF14	1.159	0.526	mm	32	78	54	7/8"-14 UNF	5/16- 18 x 1	6 28309 12606 3
Mg		CMPNDMF14	0.937	0.425							6 28309 12033 7
Zn		CMPNDZF14	2.182	0.990	in	1.25	3.06	2.3	6 28309 10836 6		
Al	E	CMPNEAC08	1.55	0.703	mm	35	86	60	1"-8 UNC	5/16- 18 x 1	6 28309 12213 3
Mg		CMPNEMC08	1.29	0.585							6 28309 11348 3
Zn		CMPNEZC08	2.63	1.193	in	1.37	3.4	2.5	6 28309 10838 0		
Al	E	CMPNEAF14	1.54	0.698	mm	35	86	60	1"-14 UNF	5/16- 18 x 1	6 28309 12566 0
Mg		CMPNEMF14	1.28	0.580							6 28309 12054 2
Zn		CMPNEZF14	2.62	1.188	in	1.37	3.4	2.5	6 28309 11510 4		
Al	F	CMPNFAC07	1.717	0.779	mm	38	89	70	1 1/8"-7 UNC	5/16- 18 x 1	6 28309 12214 0
Mg		CMPNFMC07	1.461	0.663							6 28309 11555 5
Zn		CMPNFZC07	3.002	1.362	in	1.5	3.5	2.75	6 28309 10839 7		
Al	G	CMPNGAC07	2.59	1.18	mm	45	92	79.5	1 1/4"-7 UNC	3/8- 16 x 7/8	6 28309 12215 7
Mg		CMPNGMC07	2.25	1.02							6 28309 11556 2
Zn		CMPNGZC07	4.4	2	in	1.75	3.62	3.13	6 28309 10840 3		
Al	H	CMPNHAC06	3.22	1.48	mm	51	102	83	1 1/2"-6 UNC	3/8- 16 x 7/8	6 28309 12395 6
Mg		CMPNHMC06	2.81	1.28							6 28309 11557 9
Zn		CMPNHZC06	5.25	2.39	in	2	4	3.34	6 28309 10841 0		

PROPELLER ANODES

Choose
Aluminum

Al premium
SALT AND BRACKISH WATER

Anodes for
salt and brackish
water and
Magnesium

Mg fresh
FRESH WATER ONLY
for freshwater.

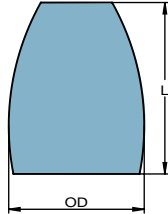

Martyr
PROPELLER ANODES

***IMPORTANT*
PROP NUT
FASTENERS:**

- Fasteners are included with all replacement prop nuts.
- Nylon patch is good for one initial application only.
- Please use lock tite or teflon tape to ensure maximum hold.

REPLACEMENT PROPELLER NUT ANODES

TYPE	PID	LB	KG		L	OD	UPC
Al	CMPNAA	0.081	0.037	mm	38	32	6 28309 11813 6
Mg	CMPNMA	0.057	0.026				6 28309 11357 5
Zn	CMPNZA	0.218	0.099				in
Al	CMPNAB	0.192	0.087	mm	52	42	6 28309 11814 3
Mg	CMPNMB	0.128	0.058				6 28309 11358 2
Zn	CMPNZB	0.513	0.233				in
Al	CMPNAC	0.436	0.198	mm	67	51	6 28309 11815 0
Mg	CMPNMC	0.273	0.124				6 28309 11359 9
Zn	CMPNZC	1.124	0.510				in
Al	CMPNAD	1.389	0.630	mm	75	58	6 28309 11816 7
Mg	CMPNMD	0.904	0.410				6 28309 11360 5
Zn	CMPNZD	3.637	1.650				in
Al	CMPNAE	0.710	0.322	mm	79	64	6 28309 11532 6
Mg	CMPNME	0.450	0.204				6 28309 11361 2
Zn	CMPNZE	1.790	0.812				in
Al	CMPNAF	0.782	0.355	mm	84	70	6 28309 11817 4
Mg	CMPNMF	0.527	0.239				6 28309 11362 9
Zn	CMPNZF	2.068	0.938				in
Al	CMPNAG	1.109	0.503	mm	88	79	6 28309 12216 4
Mg	CMPNMG	0.747	0.339				6 28309 11363 6
Zn	CMPNZG	2.934	1.331				in
Al	CMPNAH	1.230	0.558	mm	98	85	6 28309 12217 1
Mg	CMPNMH	0.774	0.351				6 28309 11364 3
Zn	CMPNZH	3.207	1.455				in

AUTOPROP™ ANODES

	PID	LB	KG		H	OD	ID	D	ID1	UPC
Al	CMPNH5A	0.125	0.057	mm	33	57	28.6	40.7	6.9	6 28309 24242 8
Mg	CMPNH5M	0.079	0.036							6 28309 24364 7
Zn	CMPNH5Z	0.330	0.150							in
Al	CMPNH6A	0.308	0.140	mm	46	74	29.6	49.4	8.8	6 28309 24243 5
Mg	CMPNH6M	0.194	0.088							6 28309 24365 4
Zn	CMPNH6Z	0.804	0.365							in

	PID	LB	KG		OD	H	D	ID	ID1	UPC
Al	CMPNH9A	0.425	0.193	mm	89	46	62.18	40	11	6 28309 25524 4
Mg	CMPNH9M	0.269	0.122							6 28309 25529 9
Zn	CMPNH9Z	1.106	0.502							in

AUTOPROP 3-BLADE PROPELLER H9

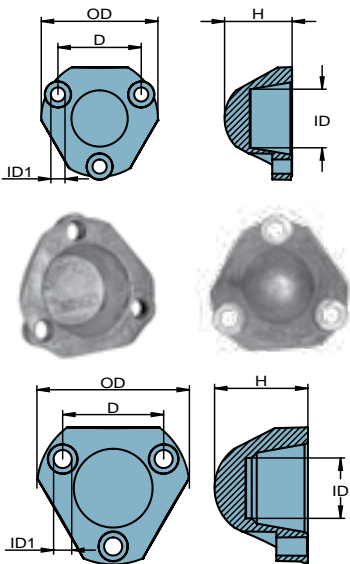

BENETEAU™ ANODES / incl. insert & hardware



Prop Nut Complete		PID	LB	KG		OD	ID	H	THD	Fastener countersink socket head w/pitch	UPC
Al	22/25 mm	CMLAEC3250A	0.465	0.211	mm	34	6.9	59	M16 x 1.5	M6 x 20 SS	6 28309 24214 5
Mg		CMLAEC3250M	0.425	0.193							6 28309 24343 2
Zn		CMLAEC3250	0.646	0.293	in	1.32	0.27	2.31			6 28309 11315 5
Al	30mm	CMLAEC3300A	0.853	0.387	mm	42	8.1	77	M20 x 1.5	M8 x 30 SS	6 28309 24215 2
Mg		CMLAEC3300M	0.767	0.348							6 28309 24344 9
Zn		CMLAEC3300	1.228	0.557	in	1.65	0.32	3.04			6 28309 11316 2
Al	35mm	CMLAEC3500A	1.096	0.497	mm	46	8.1	83	M24 x 2	M8 x 30 SS	6 28309 24216 9
Mg		CMLAEC3500M	0.989	0.449							6 28309 24345 6
Zn		CMLAEC3500	1.565	0.710	in	1.81	0.32	3.25			6 28309 11317 9
Al	40mm	CMLAEC4000A	1.591	0.722	mm	51	8.1	95	M24 x 2	M8 x 30 SS	6 28309 24217 6
Mg		CMLAEC4000M	1.442	0.654							6 28309 24346 3
Zn		CMLAEC4000	2.293	1.040	in	2.02	0.32	3.73			6 28309 11318 6
Al	45mm	CMLAEC4500A	2.467	1.119	mm	61	10.4	108	M30 x 2	M10 x 30 SS	6 28309 24218 3
Mg		CMLAEC4500M	2.207	1.001							6 28309 24347 0
Zn		CMLAEC4500	3.576	1.622	in	2.40	0.41	4.24			6 28309 11319 3
Al	45mm	CMLAEC4500EUA	2.237	1.015	mm	59	10.5	103.3	M33 x 2	M10 x 25 SS	6 28309 21165 3
Mg		CMLAEC4500EUM	1.995	0.905							6 28309 21193 6
Zn		CMLAEC4500EUZ	3.185	1.445	in	2.32	0.41	4.01			6 28309 21143 1
Al	50mm	CMLAEC5000A	3.589	1.628	mm	71	12	117	M36 x 3	M10 x 30 SS	6 28309 19266 2
Mg		CMLAEC5000M	3.214	1.458							6 28309 19305 8
Zn		CMLAEC5000	5.330	2.418	in	2.8	0.47	4.61			6 28309 18203 8
Al	55mm	CMLAEC5500A	4.140	1.878	mm	72	11	118.5	M40 x 3	M10 x 30 SS	6 28309 19267 9
Mg		CMLAEC5500M	3.765	1.708							6 28309 19306 5
Zn		CMLAEC5500	5.573	2.528	in	2.83	0.43	4.67			6 28309 18204 5
Al	60mm	CMLAEC6000A	6.036	2.738	mm	81	11	136	M45 x 3	M10 x 30 SS	6 28309 19268 6
Mg		CMLAEC6000M	5.463	2.478							6 28309 19307 2
Zn		CMLAEC6000	8.263	3.748	in	3.19	0.43	5.35			6 28309 18205 2
Al	100mm	CMLAEC10000A	9.645	4.375	mm	99	11	144	M50 x 3	M10 x 30 SS	6 28309 23713 4
Mg		CMLAEC10000M	8.895	4.035							6 28309 23714 1
Zn		CMLAEC10000	12.934	5.867	in	3.90	0.43	5.67			6 28309 23712 7

PROPELLER ANODES

BENETEAU™ REPLACEMENT ANODES

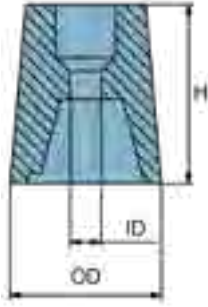

Prop Nut Replace		PID	LB	KG		H	OD	ID	UPC
Al	22/ 25mm	CMAN225A	0.111	0.050	mm	39	34	7	6 28309 19168 9
Mg		CMAN225M	0.071	0.032	in	1.55	1.32	0.27	6 28309 19324 9
Zn		CMAN225	0.290	0.131					6 28309 11308 7
Al	30mm	CMAN230A	0.230	0.104	mm	54	42	8	6 28309 19169 6
Mg		CMAN230M	0.146	0.066	in	2.11	1.65	0.32	6 28309 19325 6
Zn		CMAN230	0.600	0.272					6 28309 11309 4
Al	35mm	CMAN235A	0.289	0.131	mm	58	46	8	6 28309 19170 2
Mg		CMAN235M	0.183	0.083	in	2.28	1.81	0.32	6 28309 19326 3
Zn		CMAN235	0.758	0.344					6 28309 11310 0
Al	40mm	CMAN240A	0.419	0.190	mm	67	51	8	6 28309 19171 9
Mg		CMAN240M	0.269	0.122	in	2.62	2.02	0.32	6 28309 19327 0
Zn		CMAN240	1.119	0.508					6 28309 11311 7
Al	45mm	CMAN245A	0.690	0.313	mm	76	61	10	6 28309 19172 6
Mg		CMAN245M	0.430	0.195	in	2.99	2.4	0.40	6 28309 19328 7
Zn		CMAN245	1.800	0.816					6 28309 11312 4
Al	45mm	CMAN245EUA	0.66	0.30	mm	74	59	10.5	6 28309 21164 6
Mg		CMAN245EUM	0.42	0.19	in	2.9	2.3	0.41	6 28309 21188 2
Zn		CMAN245EUZ	1.61	0.73					6 28309 21140 0
Al	50mm	CMAN250A	1.014	0.460	mm	84	71	12	6 28309 19329 4
Mg		CMAN250M	0.639	0.290	in	3.3	2.8	0.5	6 28309 19330 0
Zn		CMAN250	1.909	0.866					6 28309 18004 1
Al	55mm	CMAN255A	0.99	0.45	mm	84	72	11	6 28309 19331 7
Mg		CMAN255M	0.62	0.28	in	3.3	2.8	0.4	6 28309 19332 4
Zn		CMAN255	2.47	1.12					6 28309 18005 8
Al	60mm	CMAN260A	1.57	0.71	mm	96	81	11	6 28309 19333 1
Mg		CMAN260M	0.99	0.45	in	3.8	3.2	0.4	6 28309 19334 8
Zn		CMAN260	3.88	1.76					6 28309 18006 5
Al	70mm	CMANCHN700A	1.345	0.610	mm	100	83	9	6 28309 12536 3
Mg		CMANCHN700M	0.857	0.389	in	3.94	3.27	0.35	6 28309 24298 5
Zn		CMANCHN700	3.527	1.600					6 28309 12535 6

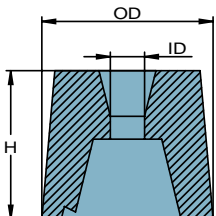
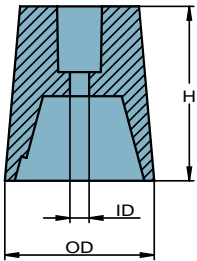

Martyr®
PROPELLER ANODES

FERRETTI™ ANODES



	PID	LB	KG		H	OD	ID	UPC
Al	CMFE1A	0.42	0.19	mm	65	50	10	6 28309 23634 2
Mg	CMFE1M	0.26	0.12					6 28309 23635 9
Zn	CMFE1Z	1.10	0.50	in	2.6	2	0.38	6 28309 23636 6

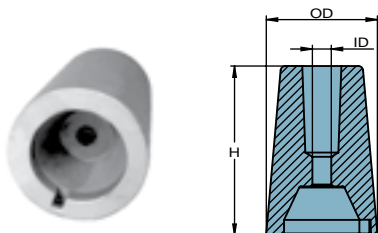

	PID	LB	KG		H	OD	ID	UPC
Al	CMFE2A	0.86	0.39	mm	90	59	10	6 28309 23637 3
Mg	CMFE2M	0.55	0.25					6 28309 23638 0
Zn	CMFE2Z	2.25	1.02	in	3.5	2.3	0.38	6 28309 23639 7



	PID	LB	KG		H	OD	ID	UPC
Al	CMFE3A	0.46	0.21	mm	65	50	7	6 28309 23640 3
Mg	CMFE3M	0.28	0.13					6 28309 23641 0
Zn	CMFE3Z	1.19	0.54	in	2.6	2	0.28	6 28309 23642 7

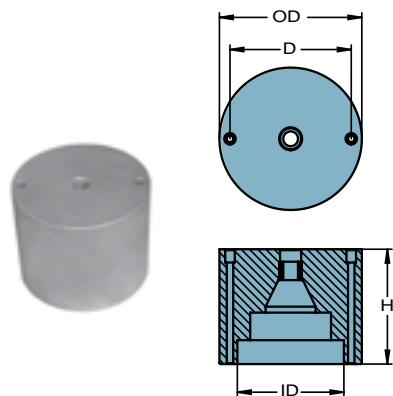

	PID	LB	KG		H	OD	D	iD	UPC
Al	CMFE80A	10.82	4.91	mm	125	155	132	116	6 28309 23649 6
Mg	CMFE80M	6.9	3.13						6 28309 23650 2
Zn	CMFE80Z	26.45	12	in	4.9	6.1	5.2	4.6	6 28309 23651 9

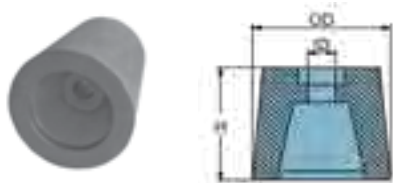

	PID	LB	KG		H	OD	ID	UPC
Al	CMFE4A	0.77	0.35	mm	75	60	10	6 28309 23643 4
Mg	CMFE4M	0.48	0.22					6 28309 23644 1
Zn	CMFE4Z	2.00	0.91	in	2.9	2.4	0.4	6 28309 23645 8

PROPELLER ANODES

Choose
Aluminum

Al premium
SALT AND BRACKISH WATER

Anodes for
salt and brackish
water and
Magnesium

Mg fresh
FRESH WATER ONLY

for freshwater.

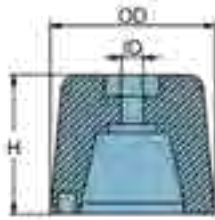

FERRETTI™ ANODES

	PID	LB	KG		H	OD	ID	UPC
Al	CMFE5A	1.54	0.70	mm	95	74	13.8	6 28309 23646 5
Mg	CMFE5M	0.99	0.45					6 28309 23647 2
Zn	CMFE5Z	4.05	1.84	in	3.7	2.9	0.54	6 28309 23648 9

FLEXOFOLD™ ANODES

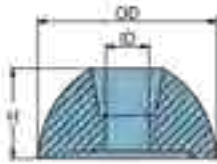
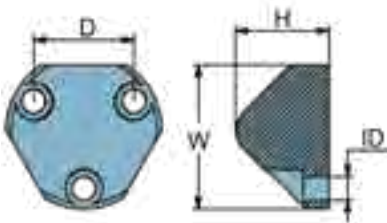

	PID	LB	KG		H	W	D	ID	UPC
Al	SGFF652A	0.264	0.120	mm	36	55	38.5	9	6 28309 18388 2
Mg	SGFF652M	0.169	0.077						6 28309 18389 9
Zn	SGFF652Z	0.690	0.313	in	1.42	2.16	1.51	0.35	6 28309 18288 5

	PID	LB	KG		OD	ID	H	UPC
Al	CMPNFXA	0.414	0.188	mm	67	8	38	6 28309 17572 6
Mg	CMPNFXM	0.260	0.118					6 28309 17621 1
Zn	CMPNFXZ	1.003	0.455	in	2.6	0.33	1.5	6 28309 17088 2

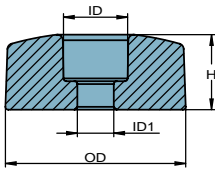

	PID	LB	KG		OD	H	ID	ID1	UPC
Al	CMPNFF2A	0.048	0.022	mm	31.7	13.3	11.25	6.4	6 28309 25185 7
Mg	CMPNFF2M	0.031	0.014						6 28309 25186 4
Zn	CMPNFF2Z	0.123	0.056	in	1.25	0.52	0.44	0.25	6 28309 25184 0

FLEX-O-FOLD 2-BLADE PROPELLER ANODE



	PID	LB	KG	Contains	UPC
Al	CMPNFF2KITA	0.260	0.118	CMPNFF2×2	6 28309 25188 8
Mg	CMPNFF2KITM	0.229	0.104		6 28309 25189 5
Zn	CMPNFF2KITZ	0.414	0.188		6 28309 25187 1

FLEX-O-FOLD 2-BLADE PROP ANODE KIT

Martyr®
PROPELLER ANODES

GORI™ ANODES

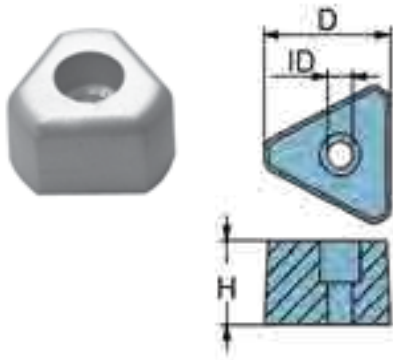

	PID	LB	KG		D	ID	H	UPC
Al	CM14072100A	0.028	0.013	mm	24	8	16	6 28309 23056 2
Mg	CM14072100M	0.019	0.009					6 28309 23072 2
Zn	CM14072100Z	0.077	0.035	in	0.9	0.33	0.6	6 28309 23038 8
Al	CM14073100A	0.042	0.019	mm	25	7	16	6 28309 23057 9
Mg	CM14073100M	0.028	0.013					6 28309 23073 9
Zn	CM14073100Z	0.094	0.043	in	1	0.26	0.6	6 28309 23039 5
Al	CM14074100A	0.079	0.036	mm	31	7	20	6 28309 23058 6
Mg	CM14074100M	0.053	0.024					6 28309 23074 6
Zn	CM14074100Z	0.194	0.088	in	1.2	0.26	0.8	6 28309 23040 1
Al	CM14074511A	0.231	0.105	mm	40	7	33	6 28309 23059 3
Mg	CM14074511M	0.154	0.070					6 28309 23075 3
Zn	CM14074511Z	0.573	0.260	in	1.6	0.26	1.3	6 28309 23041 8

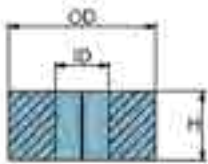

	PID	LB	KG		OD	ID	H	UPC		
(3-BLADE SHAFT)	Al	CM15539500A	0.718	0.326	mm	95	60	34	6 28309 23063 0	(3-BLADE SAILDRIVE)
	Mg	CM15539500M	0.456	0.207					6 28309 23079 1	
	Zn	CM15539500Z	1.860	0.844	in	3.7	2.4	1.3	6 28309 23045 6	
(3-BLADE SHAFT)	Al	CM15540000A	1.031	0.468	mm	95	63	47	6 28309 23064 7	(3-BLADE SAILDRIVE)
	Mg	CM15540000M	0.657	0.298					6 28309 23080 7	
	Zn	CM15540000Z	2.676	1.214	in	3.7	2.5	1.8	6 28309 23046 3	
(3-BLADE SHAFT)	Al	CM15530000A	0.70	0.32	mm	83	53	40	6 28309 23062 3	(3-BLADE SAILDRIVE)
	Mg	CM15530000M	0.44	0.20					6 28309 23078 4	
	Zn	CM15530000Z	1.90	0.86	in	3.3	2.1	1.6	6 28309 23044 9	
(3-BLADE SHAFT)	Al	CM15500000A	1.622	0.736	mm	127	90	50	6 28309 23060 9	(3-BLADE SAILDRIVE)
	Mg	CM15500000M	1.034	0.469					6 28309 23076 0	
	Zn	CM15500000Z	4.204	1.907	in	5	3.5	2	6 28309 23042 5	
(3-BLADE SAILDRIVE)	Al	CM15670000A	0.427	0.194	mm	97	80	40	6 28309 23065 4	(3-BLADE SAILDRIVE)
	Mg	CM15670000M	0.273	0.124					6 28309 23081 4	
	Zn	CM15670000Z	1.111	0.504	in	3.8	3.1	1.6	6 28309 23047 0	
(3-BLADE SAILDRIVE)	Al	CM15527500A	0.255	0.116	mm	80	55	23	6 28309 23061 6	(3-BLADE SAILDRIVE)
	Mg	CM15527500M	0.163	0.074					6 28309 23077 7	
	Zn	CM15527500Z	0.665	0.302	in	3.2	2.2	0.9	6 28309 23043 2	

PROPELLER ANODES

J-PROP™ ANODES

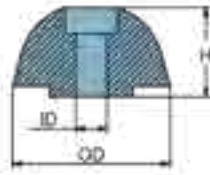

	PID	LB	KG		OD	ID	H	UPC
Al	CMJPROP60A	0.282	0.128	mm	60	9	25	6 28309 20969 8
Mg	CMJPROP60M	0.178	0.081					6 28309 20990 2
Zn	CMJPROP60Z	0.736	0.334	in	2.4	0.34	1	6 28309 20948 3
Al	CMJPROP80A	0.637	0.289	mm	80	10	33	6 28309 23676 2
Mg	CMJPROP80M	0.405	0.184					6 28309 23677 9
Zn	CMJPROP80Z	1.649	0.748	in	3.1	0.4	1.3	6 28309 23678 6
Al	CMJPROP90A	0.831	0.377	mm	90	10	37	6 28309 23679 3
Mg	CMJPROP90M	0.529	0.240					6 28309 23680 9
Zn	CMJPROP90Z	2.156	0.978	in	3.5	0.4	1.5	6 28309 23681 6

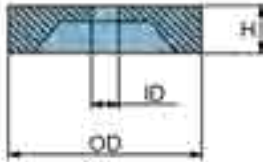

	PID	LB	KG		OD	ID	H	UPC
Al	CMJP60A	0.189	0.086	mm	60	9	15	6 28309 24213 8
Mg	CMJP60M	0.119	0.054					6 28309 24339 5
Zn	CMJP60Z	0.491	0.223	in	2.4	0.3	0.6	6 28309 24135 3

MAX PROP™ ANODES

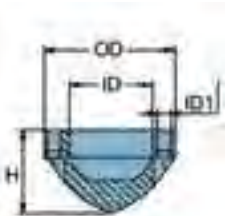

	PID	LB	KG		ID	ID1	OD	H	Fastener	UPC
Al	CMMP63RA	0.23	0.107	mm	39	5.3	62.4	39	M5 x 20	6 28309 17062 2
Mg	CMMP63RM	0.15	0.068							6 28309 17053 0
Zn	CMMP63RZ	0.61	0.278	in	1.53	0.21	2.45	1.53		6 28309 10738 3
Al	CMMP70RA	0.34	0.154	mm	43.8	4.8/5.3	68	43	M4 x 20	6 28309 17063 9
Mg	CMMP70RM	0.23	0.1							6 28309 17054 7
Zn	CMMP70RZ	0.86	0.389	in	1.72	0.19/ 0.21	2.68	1.69		6 28309 10739 0
Al	CMMP83RA	0.65	0.298	mm	47	5.3/ 6.4	82.4	57	M5 x 20	6 28309 17064 6
Mg	CMMP83RM	0.419	0.190							6 28309 17055 4
Zn	CMMP83RZ	1.666	0.756	in	1.85	0.21/ 0.25	3.24	2.24		6 28309 10740 6

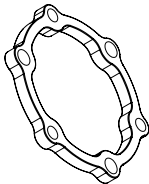

COMES WITH INSERT
- NEW DESIGN -



Martyr®
PROPELLER ANODES

MAX PROP™ ANODES

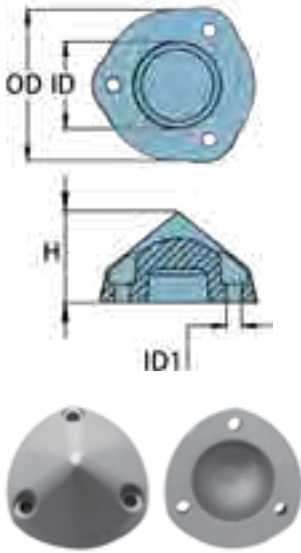

	PID	LB	KG		OD	H	ID	ID1	Fastener	UPC
Al	CMMP63MA	0.240	0.109	mm	62	39	38.3	6.3	M5 x 20SS	6 28309 23727 1
Mg	CMMP63MM	0.152	0.069							6 28309 23728 8
Zn	CMMP63MZ	0.624	0.283	in	2.44	1.54	1.51	0.25		6 28309 23729 5
Al	CMMP70MA	0.279	0.127	mm	70	41	42.4	6.3		6 28309 23733 2
Mg	CMMP70MM	0.178	0.081							6 28309 23734 9
Zn	CMMP70MZ	0.732	0.332	in	2.76	1.61	1.67	0.25		6 28309 23735 6
Al	CMMP83MA	0.685	0.311	mm	78	54	46.4	7.2	M6 x 25SS	6 28309 23739 4
Mg	CMMP83MM	0.434	0.197							6 28309 23740 0
Zn	CMMP83MZ	1.785	0.810	in	3.07	2.13	1.83	0.28		6 28309 23741 7
Al	CMMP100MA	0.778	0.353	mm	93	55	53.4	6.8		6 28309 23068 5
Mg	CMMP100MM	0.496	0.225							6 28309 23084 5
Zn	CMMP100MZ	2.019	0.916	in	3.66	2.17	2.10	0.27		6 28309 23052 4
Al	CMMP125MA	1.931	0.876	mm	127	79	82	10.8	-	6 28309 23718 9
Mg	CMMP125MM	1.225	0.556							6 28309 23719 6
Zn	CMMP125MZ	5.039	2.286	in	5.00	3.11	3.23	0.43		6 28309 23720 2

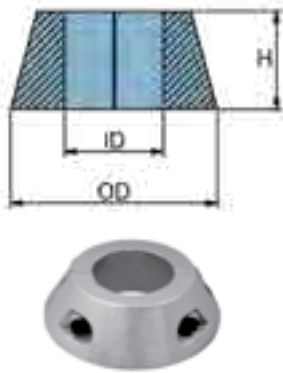

	PID	LB	KG		OD	ID	H	UPC
Al	CMMP70SDA	0.621	0.282	mm	93	42	28	6 28309 23736 3
Mg	CMMP70SDM	0.416	0.189					6 28309 23737 0
Zn	CMMP70SDZ	1.528	0.693	in	3.7	1.6	1.1	6 28309 23738 7
Al	CMMP83SDA	0.582	0.264	mm	93	46	28	6 28309 23742 4
Mg	CMMP83SDM	0.390	0.177					6 28309 23743 1
Zn	CMMP83SDZ	1.422	0.645	in	3.7	1.8	1.1	6 28309 23744 8

Choose
Aluminum

Al premium
SALT AND BRACKISH WATER

Anodes for
salt and brackish
water and
Magnesium

Mg fresh
FRESH WATER ONLY
for freshwater.

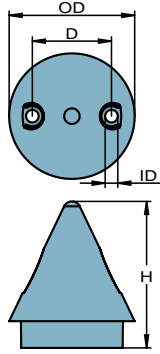

MAX PROP™ ANODES

	PID	LB	KG		OD	D	ID	H	UPC
Al	CMMP63M2BA	0.161	0.073	mm	44	27.55	4.4	51	6 28309 23724 0
Mg	CMMP63M2BM	0.101	0.046						6 28309 23725 7
Zn	CMMP63M2BZ	0.419	0.190	in	1.7	1.1	0.17	2	6 28309 23726 4



MTF™ ANODES

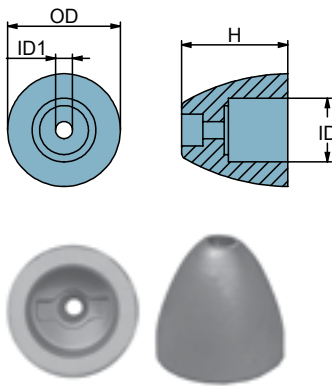

	PID	LB	KG		OD	ID	ID1	H	UPC
Al	CMMTF1A	0.101	0.046	mm	38	28	7	38	6 28309 23745 5
Mg	CMMTF1M	0.064	0.029						6 28309 23746 2
Zn	CMMTF1Z	0.264	0.120	in	1.5	1.10	0.27	1.5	6 28309 23747 9
Al	CMMTF2A	0.260	0.118	mm	53.5	35.5	7	50	6 28309 23748 6
Mg	CMMTF2M	0.165	0.075						6 28309 23749 3
Zn	CMMTF2Z	0.679	0.308	in	2.11	1.40	0.26	2	6 28309 23750 9
Al	CMMTF3A	0.602	0.273	mm	65.5	45	7	77	6 28309 23751 6
Mg	CMMTF3M	0.381	0.173						6 28309 23752 3
Zn	CMMTF3Z	1.567	0.711	in	2.6	1.8	0.28	3	6 28309 23753 0

Martyr
PROPELLER ANODES

RADICE™ ANODES

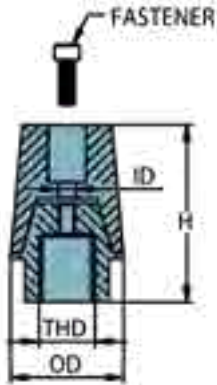

	PID	LB	KG		OD	ID	H	THD	Fastener	UPC
Al	CMLAEC3250EUA	0.45	0.21	mm	33	7	59	M16 x 1.5	M6 x 16SS	6 28309 21488 3
Mg	CMLAEC3250EUM	0.41	0.19							6 28309 21489 0
Zn	CMLAEC3250EUZ	0.61	0.28	in	1.28	0.27	2.32			6 28309 21490 6
Al	CMLAEC3300EUA	0.87	0.40	mm	44	9	74	M20 x 1.5	M8 x 25SS	6 28309 21491 3
Mg	CMLAEC3300EUM	0.77	0.35							6 28309 21492 0
Zn	CMLAEC3300EUZ	1.31	0.59	in	1.73	0.35	2.91			6 28309 21493 7
Al	CMLAEC3500EUA	1.05	0.48	mm	44	9	77	M24 x 2	M8 x 25SS	6 28309 21494 4
Mg	CMLAEC3500EUM	0.96	0.44							6 28309 21495 1
Zn	CMLAEC3500EUZ	1.41	0.64	in	1.73	0.35	3.03			6 28309 21496 8
Al	CMLAEC4000EUA	1.54	0.70	mm	50	9	93	M24 x 2	M8 x 25SS	6 28309 21497 5
Mg	CMLAEC4000EUM	1.39	0.63							6 28309 21498 2
Zn	CMLAEC4000EUZ	2.17	0.99	in	1.97	0.35	3.66			6 28309 21499 9



RADICE™ ANODES



	PID	LB	KG		OD	ID	H	THD	Fastener	UPC
Al	CMLAEC4500EUA	2.237	1.015	mm	59	10.5	103.3	M33 x 2	M10 x 25SS	6 28309 21165 3
Mg	CMLAEC4500EUM	1.995	0.905							6 28309 21193 6
Zn	CMLAEC4500EUZ	3.185	1.445	in	2.32	0.41	4.07			6 28309 21143 1
Al	CMLAEC5000A	3.589	1.628	mm	71	12	117	M36 x 3	M10 x 30SS	6 28309 19266 2
Mg	CMLAEC5000M	3.214	1.458							6 28309 19305 8
Zn	CMLAEC5000	5.330	2.418	in	2.80	0.47	4.61			6 28309 18203 8
Al	CMLAEC5500A	4.140	1.878	mm	72	11	118.5	M40 X3	M10 x 30SS	6 28309 19267 9
Mg	CMLAEC5500M	3.765	1.708							6 28309 19306 5
Zn	CMLAEC5500	5.573	2.528	in	2.80	0.43	4.67			6 28309 18204 5
Al	CMLAEC6000A	6.036	2.738	mm	81	11	136	M45 X3	M10 x 30SS	6 28309 19268 6
Mg	CMLAEC6000M	5.463	2.478							6 28309 19307 2
Zn	CMLAEC6000	8.263	3.748	in	3.19	0.43	5.35			6 28309 18205 2
Al	CMLAEC10000A	9.645	4.375	mm	99	11	144	M50 X3	M10 x 30SS	6 28309 23713 4
Mg	CMLAEC10000M	8.895	4.035							6 28309 23714 1
Zn	CMLAEC10000	12.934	5.867	in	3.90	0.43	5.67			6 28309 23712 7

RADICE™ REPLACEMENT ANODES

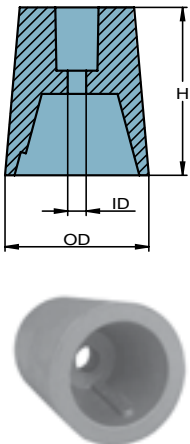

	PID	LB	KG		OD	ID	H	UPC
Al	CMAN225EUA	0.108	0.049	mm	33	7	39	6 28309 20965 0
Mg	CMAN225EUM	0.068	0.031					6 28309 20986 5
Zn	CMAN225EUZ	0.264	0.120	in	1.28	0.27	1.54	6 28309 20944 5
Al	CMAN230EUA	0.282	0.128	mm	44	9	52	6 28309 20966 7
Mg	CMAN230EUM	0.178	0.081					6 28309 20987 2
Zn	CMAN230EUZ	0.716	0.325	in	1.73	0.35	2.05	6 28309 20945 2
Al	CMAN235EUA	0.242	0.110	mm	44	9	52	6 28309 20967 4
Mg	CMAN235EUM	0.154	0.070					6 28309 20988 9
Zn	CMAN235EUZ	0.610	0.277	in	1.73	0.35	2.05	6 28309 20946 9

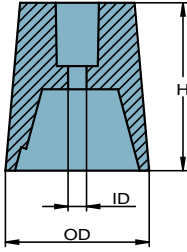

RADICE™ REPLACEMENT ANODES

	PID	LB	KG		OD	ID	H	UPC
Al	CMAN240EUA	0.410	0.186	mm	50	9	65	6 28309 20968 1
Mg	CMAN240EUM	0.260	0.118					6 28309 20989 6
Zn	CMAN240EUZ	1.036	0.470	in	1.97	0.35	2.56	6 28309 20947 6
Al	CMAN245EUA	0.66	0.30	mm	59	10.5	74	6 28309 21164 6
Mg	CMAN245EUM	0.42	0.19					6 28309 21188 2
Zn	CMAN245EUZ	1.61	0.73	in	2.32	0.41	2.91	6 28309 21140 0
Al	CMAN250A	1.014	0.460	mm	71	12	84	6 28309 19329 4
Mg	CMAN250M	0.639	0.290					6 28309 19330 0
Zn	CMAN250	2.755	1.250	in	2.8	0.5	3.3	6 28309 18004 1
Al	CMAN255A	0.99	0.45	mm	72	11	84	6 28309 19331 7
Mg	CMAN255M	0.62	0.28					6 28309 19332 4
Zn	CMAN255	2.47	1.12	in	2.8	0.4	3.3	6 28309 18005 8
Al	CMAN260A	1.57	0.71	mm	81	11	96	6 28309 19333 1
Mg	CMAN260M	0.99	0.45					6 28309 19334 8
Zn	CMAN260	3.88	1.76	in	3.2	0.4	3.8	6 28309 18006 5
Al	CMAN2100A	2.07	0.94	mm	99	11	100	6 28309 23066 1
Mg	CMAN2100M	1.32	0.60					6 28309 23082 1
Zn	CMAN2100Z	5.36	2.43	in	3.90	0.43	3.94	6 28309 23050 0

RADICE™ REPLACEMENT WASHERS

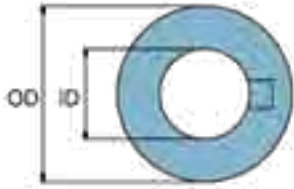

	PID	LB	KG		OD	ID	Shaft	UPC
WASHRAD2225C	0.015	0.007	mm	38	17	25	6 28309 20914 8	
			in	1.50	0.67			
WASHRAD30C	0.022	0.010	mm	46	21	30	6 28309 20915 5	
			in	1.81	0.82			
WASHRAD35C	0.026	0.012	mm	51	25	35	6 28309 20916 2	
			in	2.00	0.98			
WASHRAD40C	0.031	0.014	mm	54	25	40	6 28309 20917 9	
			in	2.12	0.98			
WASHRAD45C	0.042	0.019	mm	66	34	45	6 28309 20918 6	
			in	2.60	1.34			
WASHRAD50C	0.059	0.027	mm	76	37	50	6 28309 20919 3	
			in	3.00	1.45			
WASHRAD55C	0.066	0.030	mm	81	41	55	6 28309 20920 9	
			in	3.20	1.61			
WASHRAD60C	0.079	0.036	mm	90	46	60	6 28309 20921 6	
			in	3.54	1.81			
WASHRAD100C	0.110	0.050	mm	104	52	100	6 28309 24698 3	
			in	4.09	2.05			

RADICE™ ANODES / hexagonal

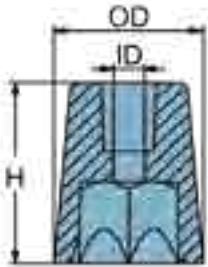

	PID	LB	KG		OD	ID	H	THD	Fastener	UPC
Al	CMPNRAD225CA	0.498	0.226	mm	33	7	40	M16 x 1.5	M6 X 20	6 28309 23296 2
Mg	CMPNRAD225CM	0.465	0.211							6 28309 24366 1
Zn	CMPNRAD225C	0.643	0.292	in	1.3	0.26	1.6			6 28309 16018 0
Al	CMPNRAD30CA	0.859	0.390	mm	42	9	53	M20 x 1.5	M8 X 20	6 28309 23297 9
Mg	CMPNRAD30CM	0.782	0.355							6 28309 24367 8
Zn	CMPNRAD30C	1.219	0.553	in	1.6	0.34	2.1			6 28309 16020 3
Al	CMPNRAD35CA	1.195	0.542	mm	46	9	62	M24 x 2	M8 X 25	6 28309 23298 6
Mg	CMPNRAD35CM	1.087	0.493							6 28309 24368 5
Zn	CMPNRAD35C	1.691	0.767	in	1.8	0.34	2.4			6 28309 16022 7
Al	CMPNRAD40CA	1.713	0.777	mm	52	9	67	M24 X 2	M8 X 20	6 28309 23299 3
Mg	CMPNRAD40CM	1.569	0.712							6 28309 24369 2
Zn	CMPNRAD40C	2.334	1.059	in	2	0.34	2.6			6 28309 16024 1
Al	CMPNRAD45C	2.412	1.094	mm	61	11	76	M33 x 2	M10 X 25	6 28309 23300 6
Mg	CMPNRAD45CM	2.180	0.989							6 28309 24370 8
Zn	CMPNRAD45C	3.426	1.554	in	2.4	0.43	3			6 28309 16026 5
Al	CMPNRAD50CA	3.796	1.722	mm	72	11	83	M36 x 3	M10 x 35	6 28309 23301 3
Mg	CMPNRAD50CM	3.512	1.593							6 28309 24371 5
Zn	CMPNRAD50C	5.042	2.287	in	2.8	0.43	3.3			6 28309 16028 9
Al	CMPNRAD55CA	4.316	1.958	mm	75	11	87	M40 x 3	M10 x 35	6 28309 24244 2
Mg	CMPNRAD55CM	4.036	1.831							6 28309 24372 2
Zn	CMPNRAD55C	5.533	2.510	in	2.9	0.43	3.4			6 28309 16030 2
Al	CMPNRAD60CA	5.890	2.672	mm	83	11	98	M45 x 3	M10 x 35	6 28309 24245 9
Mg	CMPNRAD60CM	5.366	2.434							6 28309 24373 9
Zn	CMPNRAD60C	8.192	3.716	in	3.3	0.43	3.8			6 28309 16032 6
Al	CMPNRAD100AC	8.98	4.08	mm	97	11	96	M50 x 3	M10 x 35	6 28309 23775 2
Mg	CMPNRAD100MC	8.18	3.72							6 28309 23777 6
Zn	CMPNRAD100ZC	12.47	5.67	in	3.82	0.42	3.78			6 28309 23779 0

PROPELLER ANODES

Choose
Aluminum

Al premium
SALT AND BRACKISH WATER

Anodes for
salt and brackish
water and
Magnesium

Mg fresh
FRESH WATER ONLY

for freshwater.

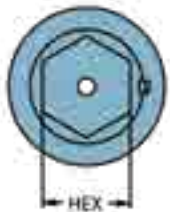
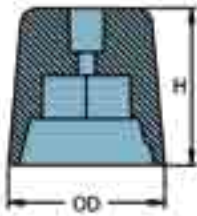

Martyr
PROPELLER ANODES

RADICE™ REPLACEMENT ANODES / hexagonal

	PID	LB	KG		OD	HEX	H	UPC
Al	CMPNRAD225A	0.092	0.042	mm	33	22	40	6 28309 19269 3
Mg	CMPNRAD225M	0.059	0.027					6 28309 19308 9
Zn	CMPNRAD225	0.242	0.110	in	1.30	0.87	1.57	6 28309 16017 3
Al	CMPNRAD30A	0.214	0.097	mm	42	27	53	6 28309 19270 9
Mg	CMPNRAD30M	0.136	0.062					6 28309 19309 6
Zn	CMPNRAD30	0.551	0.250	in	1.65	1.06	2.09	6 28309 16019 7
Al	CMPNRAD35A	0.297	0.135	mm	46	32	62	6 28309 19271 6
Mg	CMPNRAD35M	0.189	0.086					6 28309 19310 2
Zn	CMPNRAD35	0.771	0.350	in	1.81	1.26	2.44	6 28309 16021 0
Al	CMPNRAD40A	0.392	0.178	mm	52	36	67	6 28309 19272 3
Mg	CMPNRAD40M	0.249	0.113					6 28309 19311 9
Zn	CMPNRAD40	1.014	0.460	in	2.05	1.42	2.64	6 28309 16023 4
Al	CMPNRAD45A	0.639	0.290	mm	61	41	76	6 28309 19273 0
Mg	CMPNRAD45M	0.408	0.185					6 28309 19312 6
Zn	CMPNRAD45	1.653	0.750	in	2.40	1.61	2.99	6 28309 16025 8
Al	CMPNRAD50A	0.782	0.355	mm	72	46	83	6 28309 19274 7
Mg	CMPNRAD50M	0.498	0.226					6 28309 19313 3
Zn	CMPNRAD50	2.028	0.920	in	2.83	1.81	3.23	6 28309 16027 2
Al	CMPNRAD55A	0.767	0.348	mm	75	50	87	6 28309 19275 4
Mg	CMPNRAD55M	0.487	0.221					6 28309 16029 6
Zn	CMPNRAD55	1.984	0.900	in	2.95	1.97	3.43	6 28309 19314 0
Al	CMPNRAD60A	1.446	0.656	mm	83	55	98	6 28309 19276 1
Mg	CMPNRAD60M	0.921	0.418					6 28309 19315 7
Zn	CMPNRAD60	3.748	1.700	in	3.23	2.17	3.86	6 28309 16031 9
Al	CMPNRAD100A	2.109	0.957	mm	97	54	96	6 28309 23774 5
Mg	CMPNRAD100M	1.338	0.607					6 28309 23776 9
Zn	CMPNRAD100Z	5.498	2.494	in	3.82	2.13	3.78	6 28309 23778 3

REGGIANI™ ANODES

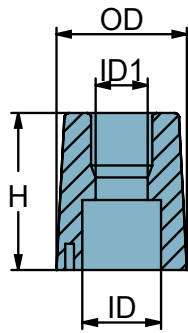

	PID	LB	KG		OD	ID	ID1	H	Shaft	UPC
Al	CMRG20A	0.072	0.033	mm	28	15	7	30	20	6 28309 23786 8
Mg	CMRG20M	0.046	0.021							6 28309 23787 5
Zn	CMRG20Z	0.189	0.086	in	1.1	0.6	0.28	1.2		6 28309 23788 2
Al	CMRG25A	0.108	0.049	mm	34	20	7	34	25	6 28309 23069 2
Mg	CMRG25M	0.068	0.031							6 28309 23085 2
Zn	CMRG25Z	0.279	0.127	in	1.3	0.8	0.28	1.3		6 28309 23053 1
Al	CMRG30A	0.279	0.127	mm	44	25	7	50	30	6 28309 23070 8
Mg	CMRG30M	0.178	0.081							6 28309 23086 9
Zn	CMRG30Z	0.725	0.329	in	1.7	1	0.27	2		6 28309 23054 8
Al	CMRG35A	0.344	0.156	mm	48	28	9	55	35	6 28309 23071 5
Mg	CMRG35M	0.218	0.099							6 28309 23087 6
Zn	CMRG35Z	0.917	0.416	in	1.9	1.1	0.34	2.2		6 28309 23055 5
Al	CMRG40A	0.416	0.189	mm	54	34	11	55	40	6 28309 23789 9
Mg	CMRG40M	0.264	0.120							6 28309 23790 5
Zn	CMRG40Z	1.080	0.490	in	2.1	1.3	0.41	2.2		6 28309 23791 2
Al	CMRG45A	0.736	0.334	mm	64	40	12	63	45	6 28309 23792 9
Mg	CMRG45M	0.469	0.213							6 28309 23793 6
Zn	CMRG45Z	1.909	0.866	in	2.5	1.6	0.47	2.5		6 28309 23794 3
Al	CMRG50A	1.206	0.547	mm	74	45	11	75	50	6 28309 23795 0
Mg	CMRG50M	0.767	0.348							6 28309 23796 7
Zn	CMRG50Z	3.126	1.418	in	2.9	1.8	0.44	3		6 28309 23797 4
Al	CMRG55A	1.345	0.610	mm	78	49	10.5	75	55	6 28309 23798 1
Mg	CMRG55M	0.882	0.400							6 28309 23799 8
Zn	CMRG55Z	3.386	1.536	in	3.1	1.9	0.41	3		6 28309 23800 1
Al	CMRG60A	2.052	0.931	mm	88	55	10.5	85	60	6 28309 23801 8
Mg	CMRG60M	1.367	0.620							6 28309 23802 5
Zn	CMRG60Z	5.062	2.296	in	3.5	2.2	0.41	3.3		6 28309 23803 2

PROPELLER ANODES

RIVA™ ANODES

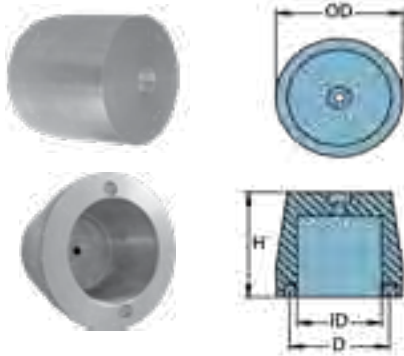

PID		LB	KG		OD	ID	D	H	UPC
Al	CMOU686A	5.88	2.67	mm	140	93	110	125	6 28309 24227 5
Mg	CMOU686M	3.72	1.69						6 28309 24360 9
Zn	CMOU686Z	15.36	6.97	in	5.51	3.66	4.33	4.92	6 28309 24139 1

SPLENDIDA 72

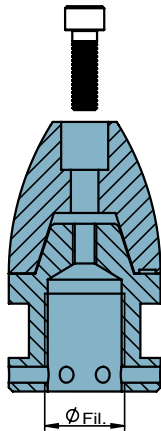

PID		LB	KG	Shaft	Ø Fil.	UPC
Zn	CMRV221615Z	0.82	0.37	22-25	16 X 1.5	6 28309 24144 5
Zn	CMRV221620Z	0.49	0.22	22-25	16 X 2	6 28309 24145 2
Al	CMRV2518175A	0.672	0.305	25	18 X 1.75	6 28309 23807 0
Mg	CMRV2518175M	0.628	0.285	25	18 X 1.75	6 28309 23808 7
Zn	CMRV2518175Z	0.871	0.395	25	18 X 1.75	6 28309 23809 4
Al	CMRV251815A	0.668	0.303	25	18 X 1.5	6 28309 23804 5
Mg	CMRV251815M	0.624	0.283	25	18 X 1.5	6 28309 23805 6
Zn	CMRV251815Z	0.866	0.393	25	18 X 1.5	6 28309 23806 3
Zn	CMRV251820Z	0.82	0.37	25	18 X 2	6 28309 24146 9
Al	CMRV302015A	0.650	0.295	30	20 X 1.5	6 28309 24252 7
Mg	CMRV302015M	0.606	0.275	30	20 X 1.5	6 28309 24381 4
Zn	CMRV302015Z	0.848	0.385	30	20 X 1.5	6 28309 24147 6
Zn	CMRV352420Z	2.76	1.25	35	24 X 2	6 28309 24148 3
Zn	CMRV402620Z	2.16	0.98	40	26 X 2	6 28309 24149 0
Zn	CMRV2230	0.82	0.37	22-30	-	6 28309 24432 3
Zn	CMRV3550	2.20	1.40	35-50	-	6 28309 24433 0

Martyr®
PROPELLER ANODES

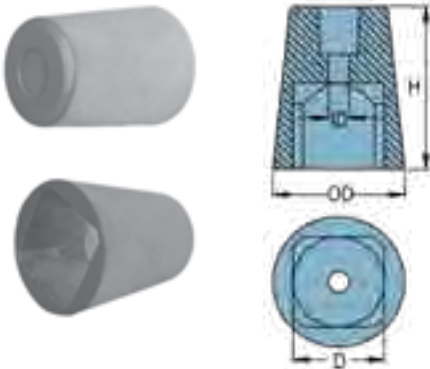

INTERNAL SQUARE ANODES

PID		LB	KG		OD	ID	H	D	UPC
Al	CMIQ648A	0.826	0.375	mm	68	11	85	47	6 28309 23673 1
Mg	CMIQ648M	0.524	0.238						6 28309 23674 8
Zn	CMIQ648Z	2.156	0.978	in	2.68	0.43	3.35	1.85	6 28309 23675 5

SHAFRAN™ ANODES

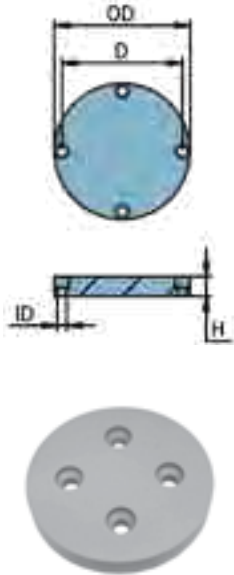

	PID	LB	KG		OD	D	ID	H	UPC					
Al	CMSH579A	1.922	0.872	mm	148	80	12	20	6 28309 23912 1					
Mg	CMSH579M	1.219	0.553						6 28309 23918 3					
Zn	CMSH579Z	5.011	2.273						in	5.8	3.1	0.47	0.8	6 28309 23906 0
Al	CMSH587A	1.922	0.872	mm	148	110	12	20						6 28309 23913 8
Mg	CMSH587M	1.219	0.553											6 28309 23919 0
Zn	CMSH587Z	5.011	2.273						in	5.8	4.3	0.47	0.8	6 28309 23907 7
Al	CMSH649A	1.636	0.742	mm	135	115	8	20						6 28309 23914 5
Mg	CMSH649M	1.036	0.470											6 28309 23920 6
Zn	CMSH649Z	4.266	1.935						in	5.3	4.5	0.31	0.8	6 28309 23908 4
Al	CMSH650A	2.149	0.975	mm	140	110	12	25						6 28309 23915 2
Mg	CMSH650M	1.362	0.618											6 28309 23921 3
Zn	CMSH650Z	5.604	2.542						in	5.5	4.3	0.47	1	6 28309 23909 1
Al	CMSH651A	1.697	0.770	mm	125	105	12	25						6 28309 23916 9
Mg	CMSH651M	1.076	0.488											6 28309 23922 0
Zn	CMSH651Z	4.424	2.007						in	4.9	4.1	0.47	1	6 28309 23910 7
Al	CMSH732A	3.172	1.439	mm	169	150	12	25						6 28309 23917 6
Mg	CMSH732M	2.010	0.912											6 28309 23923 7
Zn	CMSH732Z	8.271	3.752						in	6.29	5.90	0.47	0.98	6 28309 23911 4

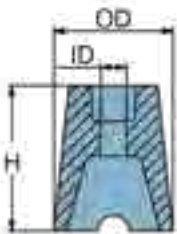

SOLE™ ANODES

	PID	LB	KG		OD	ID	H	UPC				
Al	CMPNSOLE1A	0.088	0.040	mm	32	7	39	6 28309 19277 8				
Mg	CMPNSOLE1M	0.061	0.028					6 28309 19316 4				
Zn	CMPNSOLE1	0.233	0.106					in	1.26	0.26	1.5	6 28309 16033 3
Al	CMPNSOLE2A	0.161	0.073	mm	37	9	45					6 28309 19278 5
Mg	CMPNSOLE2M	0.101	0.046									6 28309 19317 1
Zn	CMPNSOLE2	0.441	0.200					in	1.46	0.34	1.77	6 28309 16034 0
Al	CMPNSOLE3A	0.308	0.140	mm	45	9	60					6 28309 19279 2
Mg	CMPNSOLE3M	0.200	0.091									6 28309 19318 8
Zn	CMPNSOLE3	0.793	0.360					in	1.77	0.34	2.36	6 28309 16035 7
Al	CMPNSOLE4A	0.518	0.235	mm	55	9	70					6 28309 19280 8
Mg	CMPNSOLE4M	1.124	0.510									6 28309 19319 5
Zn	CMPNSOLE4	1.322	0.600					in	2.17	0.34	2.76	6 28309 16036 4



PLEASURECRAFT

P R O P N U T &

B O W T H R U S T E R

A N O D E S

LEWMAR™ ANODES

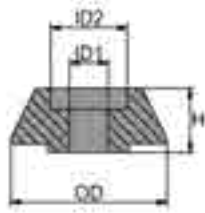

	PID	LB	KG		H	OD	ID1	ID2	UPC
Al	CM589150A	0.068	0.031	mm	14	38	8	18	6 28309 23368 6
Mg	CM589150M	0.048	0.022						6 28309 23372 3
Zn	CM589150Z	0.163	0.074						6 28309 23373 0
Al	CM589350A	0.099	0.045	mm	15	45	10	24	6 28309 23374 7
Mg	CM589350M	0.068	0.031						6 28309 23378 5
Zn	CM589350Z	0.231	0.105						6 28309 23379 2
Al	CM589550A	0.227	0.103	mm	20	60	17	34	6 28309 23380 8
Mg	CM589550M	0.156	0.071						6 28309 23384 6
Zn	CM589550Z	0.540	0.245						6 28309 23385 3



LEWMAR™ ANODE KITS

	PID	LB	KG	Contains	Fits	UPC
Al	CM589150KITA	0.222	0.101	CM589150×1	Lewmar 140TT Thruster 589150	6 28309 23369 3
Mg	CM589150KITM	0.203	0.092			6 28309 23370 9
Zn	CM589150KITZ	0.317	0.144			6 28309 23371 6



	PID	LB	KG	Contains	Fits	UPC
Al	CM589350KITA	0.277	0.126	CM589350×1	Lewmar 185TT Thruster 589350	6 28309 23375 4
Mg	CM589350KITM	0.260	0.118			6 28309 23376 1
Zn	CM589350KITZ	0.410	0.186			6 28309 23377 8



	PID	LB	KG	Contains	Fits	UPC
Al	CM589550KITA	0.749	0.340	CM589550×2	Lewmar 250/300TT Thruster 589550	6 28309 23381 5
Mg	CM589550KITM	0.613	0.278			6 28309 23382 2
Zn	CM589550KITZ	1.371	0.622			6 28309 23383 9

MAX POWER™ ANODES

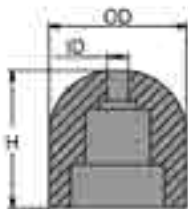

	PID	LB	KG		H	OD	ID	UPC
Al	CMMP586A	0.079	0.036	mm	32	32	7	6 28309 21500 2
Mg	CMMP586M	0.050	0.023					6 28309 21501 9
Zn	CMMP586Z	0.205	0.093	in	1.3	1.3	0.26	6 28309 21502 6

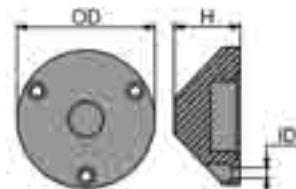

	PID	LB	KG		H	OD	ID	UPC
Al	CMMP676A	0.416	0.189	mm	38	79	6	6 28309 23730 1
Mg	CMMP676M	0.264	0.120					6 28309 23731 8
Zn	CMMP676Z	1.080	0.490	in	1.5	3.1	0.25	6 28309 23732 5

Protect your boat, respect our waters.

PLEASURECRAFT

H U L L

A N O D E S

GROUPE

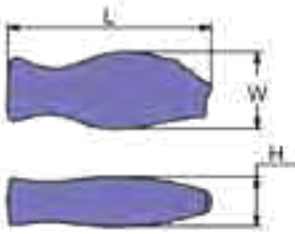

	PID	LB	KG		L	W	H	UPC
Al	CMGROUPEA	2.64	1.20	mm	195.6	74.2	48.1	6 28309 12219 5
Mg	CMGROUPEM	1.89	0.86					6 28309 12368 0
Zn	CMGROUPE	5.88	2.67	in	7.70	2.92	1.89	6 28309 10514 3

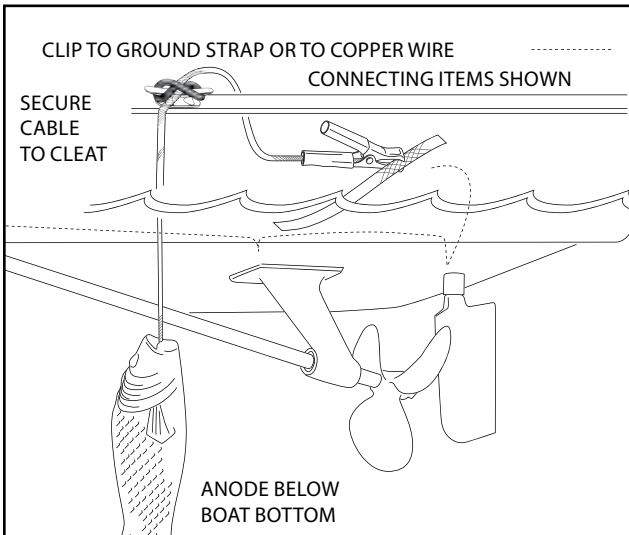
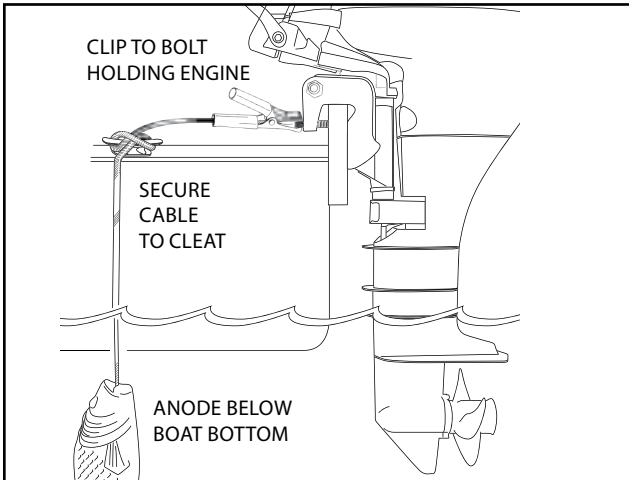
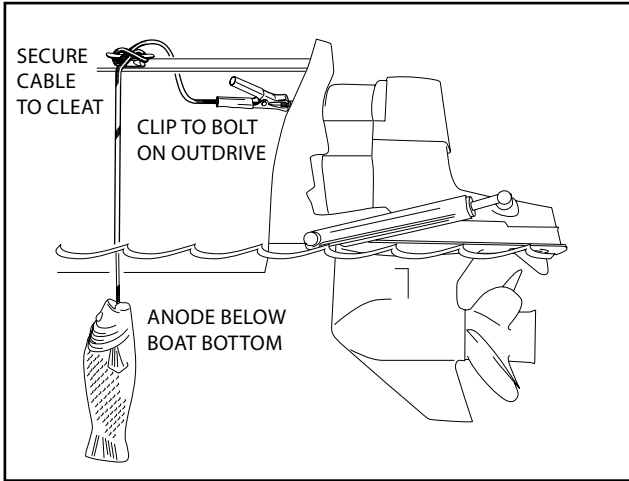

*** IMPORTANT* Do not connect to battery**

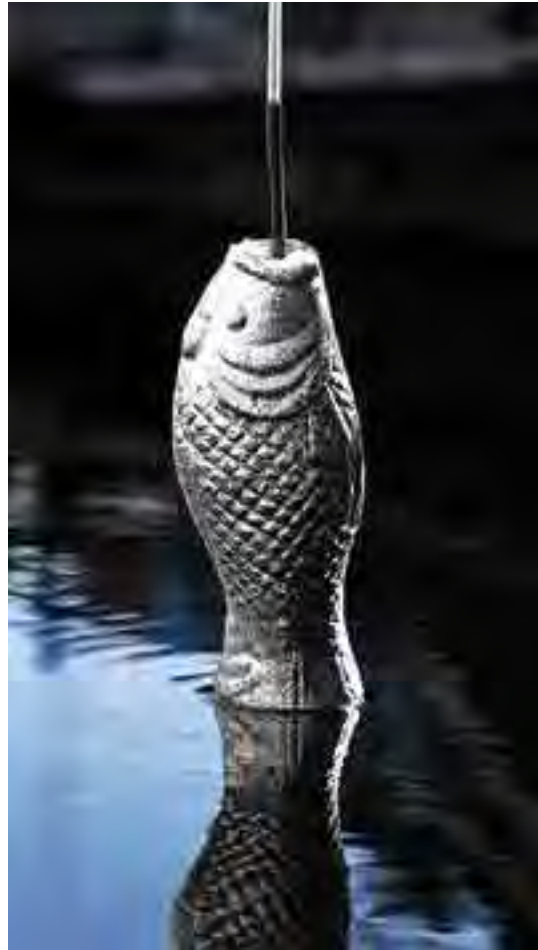

HULL ANODES

Choose
Aluminum

Al premium
SALT AND BRACKISH WATER

Anodes for
salt and brackish
water and
Magnesium

Mg fresh
FRESH WATER ONLY
for freshwater.

BONDING KIT / hardware included

	PID	LB	KG	Contains		L	W	W1	H	D	D1	UPC
Al	CMDIVERBONDA	4	1.82	CMDIVERA×1 BAGDIVERBONDA×1	mm	305	152	13	13	140	89	6 28309 12284 3
Zn	CMDIVERBONDZ	8.04	3.65		in	12	6	0.5	0.5	5.5	3.5	6 28309 24725 6

Please Note: It is strongly recommended that this anode kit be installed by a certified marine technician.

Legal Disclaimer: CMP is not liable for any damages resulting from improper installation of this kit and its contents.

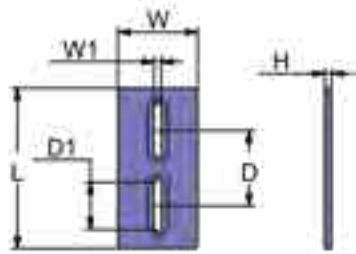

Martyr
HULL ANODES

DIVER'S DREAM MINI

	PID	LB	KG		L	W	W1	H	D	D1	UPC
Al	CMDIVERMINIA	1.058	0.480	mm	150	99	11	13	69	35	6 28309 12375 8
Mg	CMDIVERMINIM	0.793	0.360								6 28309 11506 7
Zn	CMDIVERMINI	2.231	1.012	in	5.9	3.9	0.44	0.5	2.7	1.36	6 28309 11338 4

BOLT-ON

SEE PART ID: CMDIVERMINIHZ FOR A HEAVIER VERSION

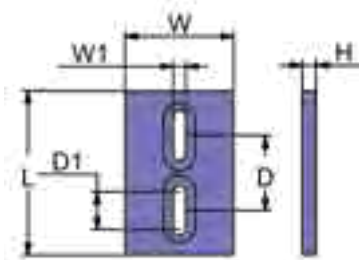

DIVER'S DREAM

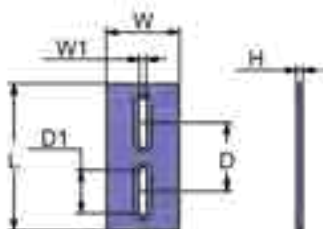

	PID	LB	KG		L	W	H	D	D1	W1	UPC
Al	CMDIVERA	3.48	1.58	mm	304	152	13	140	89	13	6 28309 10183 1
Mg	CMDIVERM	2.50	1.14								6 28309 11507 4
Zn	CMDIVERZ	7.52	3.41	in	12	6	0.5	5.5	3.5	0.5	6 28309 11365 0



DIVER'S DREAM HEAVY DUTY

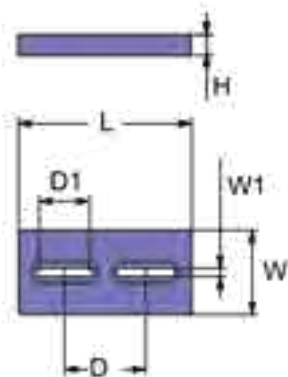

	PID	LB	KG		L	W	H	D	D1	W1	UPC
Al	CMDIVERHA	6.129	2.780	mm	304	152	25	140	89	13	6 28309 18990 7
Mg	CMDIVERHM	4.219	1.914								6 28309 19000 2
Zn	CMDIVERHZ	14.552	6.601	in	12	6	1	5.5	3.5	0.5	6 28309 18981 5

DOUBLE THE WEIGHT OF CMDIVER

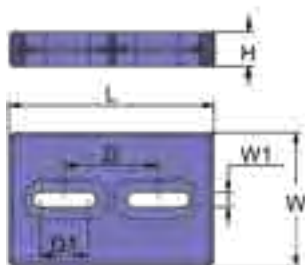

	PID	LB	KG		L	W	H	D	D1	W1	UPC
Al	CMDIVERMINIHA	1.96	0.89	mm	149.86	99.06	25.4	68.58	34.54	11.17	6 28309 24694 5
Mg	CMDIVERMINIHM	1.37	0.62								6 28309 24695 2
Zn	CMDIVERMINIHZ	4.65	2.11	in	5.9	3.9	1	2.7	1.36	0.44	6 28309 24693 8

BOLT-ON DIVERMINI HEAVY PLATE
DOUBLE THE WEIGHT OF CMDIVERMINI

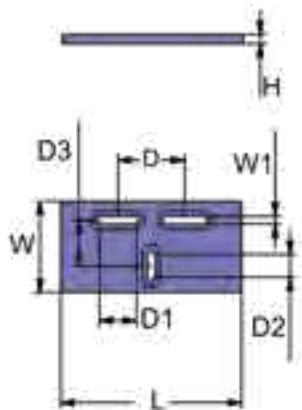

	PID	LB	KG		L	W	W1	H	D	D1	D2	D3	UPC
Al	CMZ10A	3.850	1.746	mm	304	152	13	13	114	64	36	76	6 28309 19152 8
Mg	CMZ10M	2.400	1.088										6 28309 19247 1
Zn	CMZ10Z	9.855	4.470	in	12	6	0.5	0.6	1.5	2.5	1.42	3	6 28309 13020 6



HULL ANODES

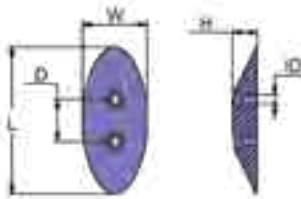

	PID	LB	KG		L	W	H	D	ID	UPC
Al	CMM24A	0.247	0.112	mm	111	49	18.5	32	6	6 28309 12376 5
Mg	CMM24M	0.152	0.069							6 28309 24353 1
Zn	CMM24	0.639	0.290	in	4.36	1.92	0.73	1.25	0.25	6 28309 10679 9

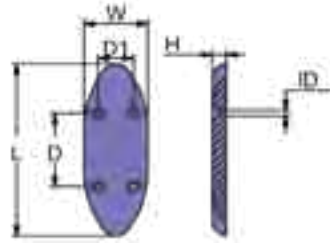

	PID	LB	KG		L	W	H	D	D1	ID	UPC
Al	CMM25A	1.292	0.586	mm	231	83	18	98	46	7	6 28309 12377 2
Mg	CMM25M	0.822	0.373								6 28309 24354 8
Zn	CMM25	3.390	1.538	in	9.08	3.25	0.72	3.86	1.81	0.29	6 28309 10680 5



	PID	LB	KG		L	W	H	D	D1	D2	ID	UPC
Al	CMM30A	0.745	0.338	mm	154	68	14	121	118	40	6	6 28309 12378 9
Mg	CMM30M	0.469	0.213									6 28309 24355 5
Zn	CMM30	1.916	0.869	in	6.06	2.67	0.56	4.75	4.62	1.58	0.25	6 28309 10681 2

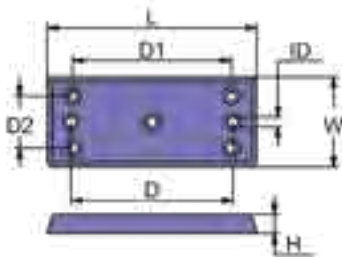

	PID	LB	KG		L	W	H	D1	D2	ID	UPC
Al	CMM40A	0.815	0.370	mm	186	66	13	44	35	7	6 28309 12379 6
Mg	CMM40M	0.529	0.240								6 28309 24356 2
Zn	CMM40	2.094	0.950	in	7.3	2.6	0.5	1.75	1.38	0.25	6 28309 10682 9

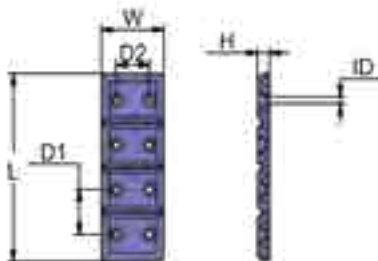

Martyr
HULL ANODES

HULL ANODES

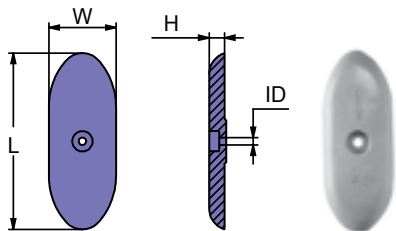

	PID	LB	KG		L	W	H	ID	UPC
Al	CMMZ404A	1.480	0.671	mm	224	86	19	10	6 28309 12380 2
Mg	CMMZ404M	0.950	0.431						6 28309 18507 7
Zn	CMMZ404	3.750	1.701	in	8.8	3.38	0.75	0.38	6 28309 11339 1

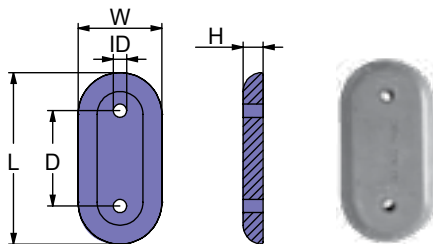

	PID	LB	KG		L	W	H	D	ID	UPC
Al	CMMZC406A	3.280	1.487	mm	229	112	25	127	13	6 28309 12381 9
Mg	CMMZC406M	2.140	0.970							6 28309 17620 4
Zn	CMMZC406	8.150	3.696	in	9	4.4	1	5	0.5	6 28309 11340 7

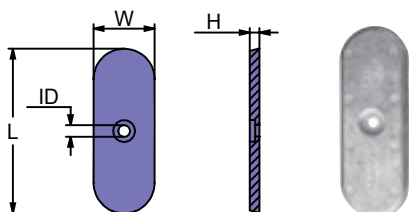

	PID	LB	KG		L	W	H	ID	UPC
Al	CMN1A	0.990	0.449	mm	216	80	13	10	6 28309 12347 5
Mg	CMN1M	0.626	0.284						6 28309 24357 9
Zn	CMN1Z	2.580	1.170	in	8.5	3.15	0.5	0.41	6 28309 12348 2

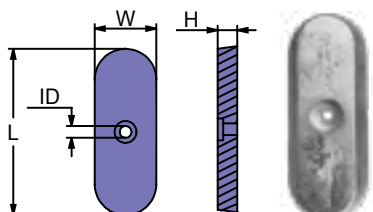

	PID	LB	KG		L	W	H	ID	UPC
Al	CMN1HA	1.892	0.858	mm	219	84	25.4	10	6 28309 27439 9
Mg	CMN1HM	1.206	0.547						6 28309 27440 5
Zn	CMN1HZ	4.904	2.224	in	8.63	3.31	1	0.4	6 28309 27438 2

NEW PRODUCTS

HULL ANODES

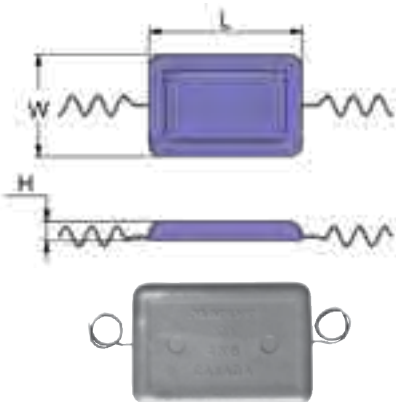

	PID	LB	KG		L	W	H	UPC
Al	CMPMWA	0.78	0.35	mm	114	64	17	6 28309 12558 5
Mg	CMPMWM	0.60	0.27					6 28309 24363 0
Zn	CMPMWZ	2.00	0.91	in	4.5	2.5	0.65	6 28309 11266 0
Al	CMPNWA	1.26	0.57	mm	152	76	19	6 28309 12559 2
Mg	CMPNWM	0.97	0.44					6 28309 24374 6
Zn	CMPNWZ	3.25	1.48	in	6	3	0.75	6 28309 11268 4
Al	CMPOWA	1.70	0.77	mm	152	102	19	6 28309 12560 8
Mg	CMPOWM	1.15	0.52					6 28309 24376 0
Zn	CMPOWZ	4.38	1.99	in	6	4	0.75	6 28309 11270 7
Al	CMPPWA	3.590	1.628	mm	229	127	20	6 28309 12561 5
Mg	CMPPWM	2.300	1.043					6 28309 24377 7
Zn	CMPPWZ	9.250	4.195	in	9	5	0.8	6 28309 11272 1



Choose
Aluminum

Al premium
SALT AND BRACKISH WATER

Anodes for
salt and brackish
water and
Magnesium

Mg fresh
FRESH WATER ONLY
for freshwater.

HULL ANODES

	PID	LB	KG		L	W	H	D	D1	ID	UPC
Al	CMAC073A	0.392	0.178	mm	110	67	21	39	27	6	6 28309 23532 1
Mg	CMAC073M	0.251	0.114	in	4.3	2.6	0.8	1.54	1.1	0.22	6 28309 23533 8
Zn	CMAC073Z	1.020	0.463								6 28309 23534 5

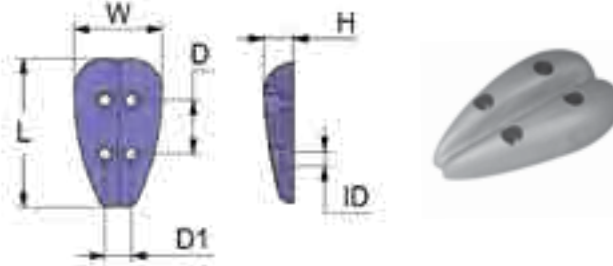

	PID	LB	KG		L	W	H	D	D1	ID	ID1	UPC
Al	CMPO029A	0.86	0.39	mm	122	81	20	69	35	9	6	6 28309 24246 6
Mg	CMPO029M	0.54	0.24	in	4.8	3.2	0.8	2.7	1.38	0.33	0.24	6 28309 24375 3
Zn	CMPO029Z	2.20	1.00									6 28309 24143 8

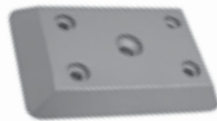
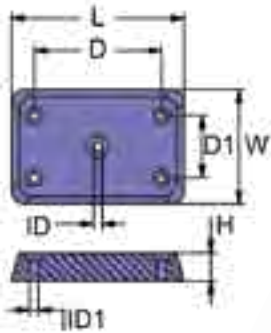

	PID	LB	KG		L	W	H	D	ID	UPC
Al	CMCH006A	0.145	0.066	mm	120	35	10	51	7	6 28309 23598 7
Mg	CMCH006M	0.092	0.042	in	4.7	1.4	0.4	2	0.28	6 28309 23599 4
Zn	CMCH006Z	0.381	0.173							6 28309 23600 7

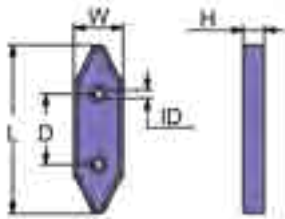

CHRYSLER SERIES

	PID	LB	KG		L	W	H	D	D1	ID	UPC
Zn	CMZH470Z	4.30	1.95	mm	395	37	30	48	145	25	6 28309 24153 7
				in	15.5	1.5	1.2	1.9	5.7	1.0	

ZINC PLATE FOR FAST HULLS

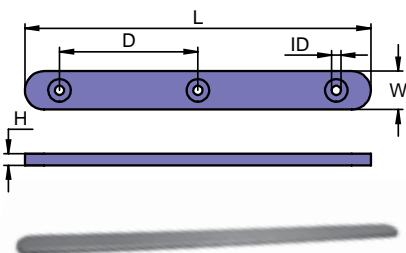
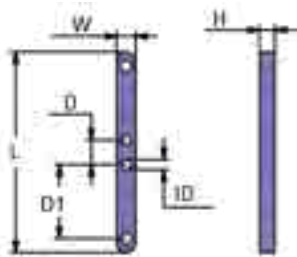

	PID	LB	KG		L	W	H	D	ID	UPC
Zn	CMZH058Z	Contact us for more info		mm	910	45	12	380	9	6 28309 24152 0
				in	35.7	1.8	0.5	15.0	0.35	
Zn	CMZH058NZ	Contact us for more info		mm	900	45	15	380	9	6 28309 24151 3
				in	35.7	1.8	0.6	15.0	0.35	

ZINC PLATE FOR HYDROFOIL AND FAST HULLS

HULL ANODES

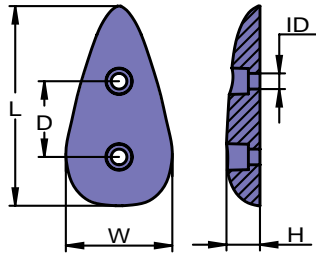

	PID	LB	KG		L	W	H	D	ID	UPC
Al	CMT20A	0.141	0.064	mm	86	46	15	33	6	6 28309 12398 7
Mg	CMT20M	0.090	0.041							6 28309 12191 4
Zn	CMT20	0.370	0.168	in	3.4	1.8	0.6	1.28	0.25	6 28309 10358 3
Al	CMT21A	0.374	0.170	mm	129	51	21	41	8	6 28309 12396 3
Mg	CMT21M	0.242	0.110							6 28309 24385 2
Zn	CMT21	0.992	0.450	in	5	2	0.8	1.63	0.31	6 28309 10358 3

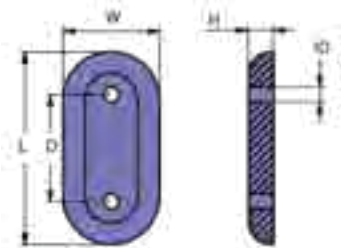

	PID	LB	KG		L	W	H	D	ID	UPC
Al	CMZ24BSA	8.400	3.810	mm	356	159	32	127	13	6 28309 12563 9
Mg	CMZ24BSM	5.100	2.313							6 28309 24414 9
Zn	CMZ24BSZ	21.00	9.525	in	14	6.25	1.25	5	0.5	6 28309 12482 3

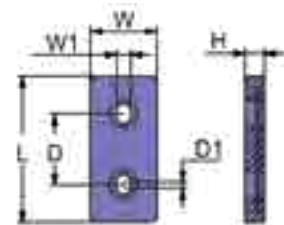

	PID	LB	KG		L	W	W1	H	D	D1	UPC
Al	CMZHC2AA	0.887	0.402	mm	146	64	13	19	71	6	6 28309 11401 5
Mg	CMZHC2AM	0.544	0.246								6 28309 17625 9
Zn	CMZHC2AZ	2.215	1.004	in	5.75	2.65	0.5	0.75	2.78	0.25	6 28309 11225 7

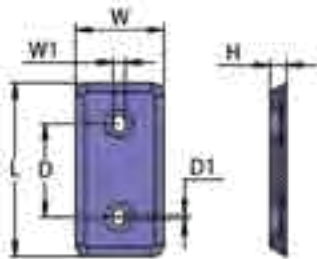

	PID	LB	KG		L	W	W1	H	D	D1	UPC
Al	CMZHC5AA	1.80	0.81	mm	203	102	14	19	110	6	6 28309 12312 3
Mg	CMZHC5AM	1.18	0.53								6 28309 24421 7
Zn	CMZHC5AZ	4.68	2.12	in	8	4	0.55	0.76	4.35	0.23	6 28309 11228 8

HULL ANODES

HULL ANODES

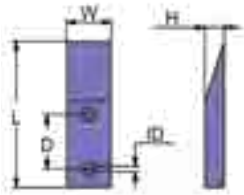

	PID	LB	KG		L	W	H	D	ID	UPC
Al	CMPL505A	1.76	0.80	mm	210	70	25	80	18	6 28309 23771 4
Mg	CMPL505M	1.25	0.57							6 28309 23772 1
Zn	CMPL505Z	4.08	1.85	in	8.27	2.76	0.98	3.1	0.71	6 28309 23773 8

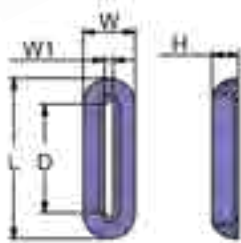

	PID	LB	KG		L	W	W1	H	D	UPC
Al	SGFL501A	1.459	0.662	mm	200	65	12	35	98	6 28309 19119 1
Mg	SGFL501M	0.998	0.453							6 28309 19134 4
Zn	SGFL501Z	3.048	1.383	in	7.9	1.6	1	2.4	3.85	6 28309 18113 0

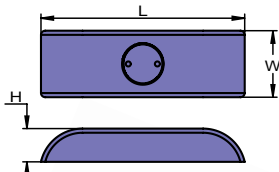

	PID	LB	KG		L	W	H	UPC
Al	CMZH479A	4.043	1.834	mm	245	80	40	6 28309 24262 6
Mg	CMZH479M	2.610	1.184					6 28309 24418 7
Zn	CMZH479Z	10.331	4.686	in	9.6	3.1	1.6	6 28309 24154 4

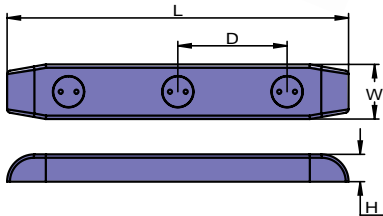

	PID	LB	KG		L	W	H	D	UPC
Al	CMZH494A	8.437	3.827	mm	500	80	40	160	6 28309 24262 6
Mg	CMZH494M	5.348	2.426						6 28309 24418 7
Zn	CMZH494Z	21.997	9.978	in	19.6	3.1	1.6	6.3	6 28309 23851 3

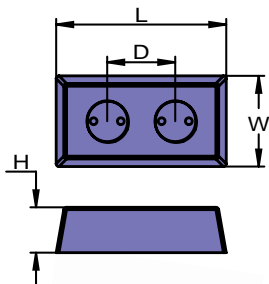

	PID	LB	KG		L	W	H	D	UPC
Al	CMZH504A	2.229	1.011	mm	150	80	40	60	6 28309 24263 3
Mg	CMZH504M	1.413	0.641						6 28309 24419 4
Zn	CMZH504Z	5.813	2.637	in	5.9	3.1	1.6	2.4	6 28309 24155 1



Martyr
HULL ANODES

HULL ANODES

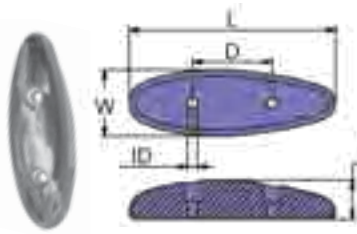

	PID	LB	KG		L	W	H	D	ID	UPC
Al	SGAO072A	0.42	0.19	mm	130	41	25	50	6	6 28309 22489 9
Mg	SGAO072M	0.26	0.12						6	6 28309 22722 7
Zn	SGAO072Z	1.10	0.50	in	5.12	1.63	0.97	1.97	0.24	6 28309 21769 3

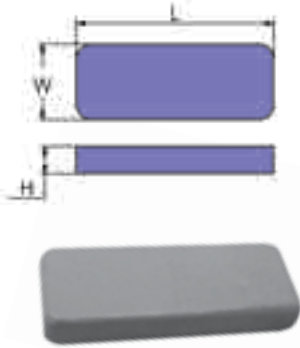

	PID	LB	KG		L	W	H		UPC
Al	CMFL075A	0.591	0.268	mm	130	50	18	6	6 28309 24573 3
Mg	CMFL075M	0.374	0.170					6	6 28309 24612 9
Zn	CMFL075Z	1.543	0.700	in	5.12	1.97	0.71	6	6 28309 24463 7
Al	CMFL074A	1.267	0.575	mm	150	70	21.5	6	6 28309 24572 6
Mg	CMFL074M	0.802	0.364					6	6 28309 24611 2
Zn	CMFL074Z	3.306	1.500	in	5.91	2.76	0.85	6	6 28309 24462 0
Al	CMFL076A	0.928	0.421	mm	110	70	21.5	6	6 28309 24574 0
Mg	CMFL076M	0.588	0.267					6	6 28309 24614 3
Zn	CMFL076Z	2.425	1.100	in	4.33	2.76	0.85	6	6 28309 24465 1
Al	CMRF104A	6.428	2.916	mm	300	150	25	6	6 28309 24591 7
Mg	CMRF104M	4.074	1.848					6	6 28309 24630 3
Zn	CMRF104Z	16.755	7.600	in	11.8	5.91	1	6	6 28309 24480 4
Al	CMZH480A	5.408	2.453	mm	300	150	20	6	6 28309 24610 5
Mg	CMZH480M	3.428	1.555					6	6 28309 24649 5
Zn	CMZH480Z	14.109	6.400	in	11.8	5.91	0.79	6	6 28309 24571 9

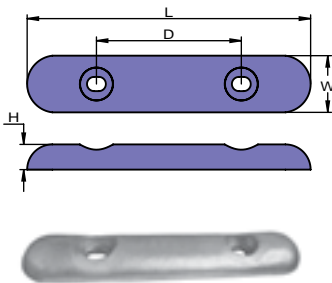

	PID	LB	KG		L	W	D	H	UPC
Al	CMSH505A	6.834	3.100	mm	450	90	230	40	6 28309 24603 7
Mg	CMSH505M	5.070	2.300					6	6 28309 24642 6
Zn	CMSH505Z	15.212	6.900	in	17.7	3.54	9.06	1.57	6 28309 24564 1
Zn	CMSH514	15.4	7	mm	455	95	230	55	6 28309 24565 8
				in	17.91	3.74	9.06	2.16	

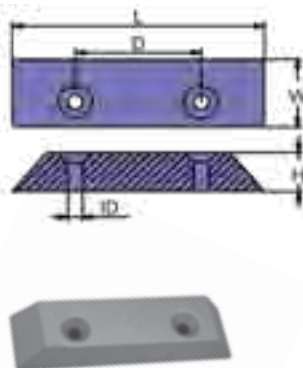

	PID	LB	KG		L	W	H	D	ID	UPC
Al	SGPL356A	0.37	0.17	mm	120	34	20	60	7	6 28309 18340 0
Mg	SGPL356M	0.24	0.11						6	6 28309 18391 2
Zn	SGPL356Z	0.88	0.40	in	4.72	1.34	0.79	2.36	0.28	6 28309 18290 8
Al	SGPL576A	0.59	0.27	mm	175	34	20	100	7	6 28309 18343 1
Mg	SGPL576M	0.37	0.17						6	6 28309 18394 3
Zn	SGPL576Z	1.44	0.66	in	6.89	1.34	0.79	3.94	0.28	6 28309 18293 9

HULL ANODES

Choose
Aluminum

Al premium
SALT AND BRACKISH WATER

Anodes for
salt and brackish
water and
Magnesium

Mg fresh
FRESH WATER ONLY
for freshwater.

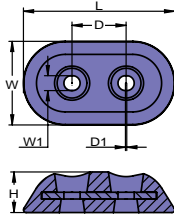

HULL ANODES

	PID	LB	KG		L	W	W1	D	D1	H	UPC
Al	SGPL355A	0.75	0.34	mm	115	65	11	40	1	30	6 28309 18339 4
Mg	SGPL355M	0.55	0.25								6 28309 18390 5
Zn	SGPL355Z	1.52	0.69	in	4.53	2.56	0.43	1.57	0.04	1.18	6 28309 18289 2

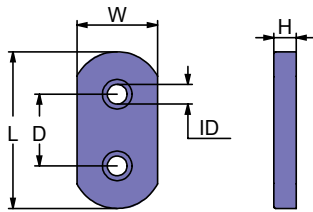

	PID	LB	KG		L	W	D	H	ID	UPC
Al	SGPL573A	2.220	1.007	mm	175	90	80	25	13	6 28309 18342 4
Mg	SGPL573M	1.547	0.702							6 28309 18393 6
Zn	SGPL573Z	5.081	2.305	in	6.9	3.54	3.15	1	0.51	6 28309 18292 2
Al	SGPL572A	3.44	1.56	mm	200	110	130	30	14	6 28309 18341 7
Mg	SGPL572M	2.20	1							6 28309 18392 9
Zn	SGPL572Z	7.96	3.61	in	7.87	4.33	5.12	1.18	0.55	6 28309 18291 5

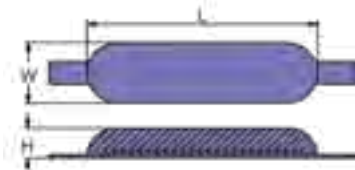

	PID	LB	KG		L	W	H	UPC
Al	SGSH16A	4.94	2.24	mm	300	80	40	6 28309 22624 4
Mg	SGSH16M	3.53	1.60					6 28309 22844 6
Zn	SGSH16Z	11.22	5.09	in	11.8	3.15	1.57	6 28309 22293 2
Al	SGSH25A	8.07	3.66	mm	320	147	40	6 28309 22625 1
Mg	SGSH25M	5.51	2.50					6 28309 22845 3
Zn	SGSH25Z	19.38	8.79	in	12.6	5.79	1.57	6 28309 22294 9

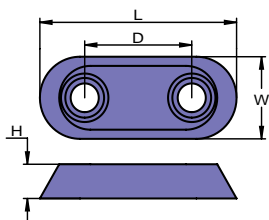

	PID	LB	KG		L	W	H	D	UPC
Al	SGVT070A	0.895	0.406	mm	147	60	25	80	6 28309 18224 3
Mg	SGVT070M	0.657	0.298						6 28309 18236 6
Zn	SGVT070Z	1.907	0.865	in	5.79	2.36	1	3.15	6 28309 18212 0
Al	SGVT507A	2.568	1.165	mm	290	53	30	200	6 28309 18226 7
Mg	SGVT507M	1.827	0.829						6 28309 18238 0
Zn	SGVT507Z	5.732	2.600	in	11.4	2.1	1.18	7.87	6 28309 18214 4
Al	SGVT240A	2.270	1.030	mm	250	62	30	140	6 28309 18225 0
Mg	SGVT240M	1.585	0.719						6 28309 18237 3
Zn	SGVT240Z	5.269	2.390	in	9.84	2.44	1.18	5.51	6 28309 18213 7
Al	SGVT695A	5.009	2.272	mm	350	75	35	200	6 28309 18366 0
Mg	SGVT695M	3.386	1.536						6 28309 18417 9
Zn	SGVT695Z	11.464	5.200	in	13.8	3	1.4	7.87	6 28309 18316 5

Martyr
HULL ANODES

HULL ANODES

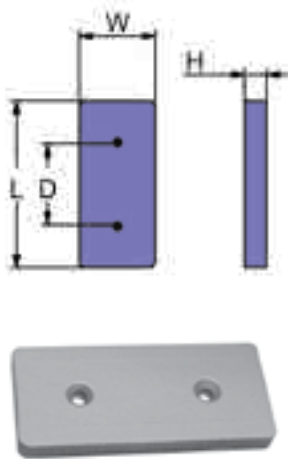

	PID	LB	KG		L	W	H	D	UPC
Al	CMPL078A	0.271	0.123	mm	100	50	10	50	6 28309 24584 9
Mg	CMPL078M	0.172	0.079						6 28309 24623 5
Zn	CMPL078Z	0.707	0.321						6 28309 24473 6
Zn	CMPL419Z	6.17	2.80	mm	200	100	20	110	6 28309 24478 1
				in	7.87	3.94	0.79	4.33	
Al	CMPL400A	1.28	0.58	mm	150	60	25	80	6 28309 24587 0
Mg	CMPL400M	0.92	0.42						6 28309 24626 6
Zn	CMPL400Z	2.78	1.26						in
Al	CMPL401A	1.96	0.89	mm	180	75	25	115	6 28309 24588 7
Mg	CMPL401M	1.41	0.64						6 28309 24627 3
Zn	CMPL401Z	4.49	2.04						in
Al	CMPL378A	0.70	0.32	mm	120	50	20	75	6 28309 24586 3
Mg	CMPL378M	0.55	0.25						6 28309 24625 9
Zn	CMPL378Z	1.36	0.62						in
Al	CMFL075FA	0.59	0.27	mm	130	50	18	77	6 28309 23136 1
Mg	CMFL075FM	0.37	0.17						6 28309 23137 8
Zn	CMFL075FZ	1.54	0.70						in
Al	CMFL076FA	0.88	0.4	mm	110	70	20	40	6 28309 24575 7
Mg	CMFL076FM	0.62	0.28						6 28309 24613 6
Zn	CMFL076FZ	2.00	0.91						in
Al	CMPL357A	2.09	0.95	mm	220	60	30	160	6 28309 24585 6
Mg	CMPL357M	1.32	0.60						6 28309 24624 2
Zn	CMPL357Z	5.47	2.48						in
Al	CMFL465A	1.192	0.541	mm	145	67	20	70	6 28309 23655 7
Mg	CMFL465M	0.879	0.399						6 28309 23656 4
Zn	CMFL465Z	2.570	1.166						in
Al	CMPL574A	1.49	0.68	mm	190	55	25	75	6 28309 24590 0
Mg	CMPL574M	1.04	0.47						6 28309 24629 7
Zn	CMPL574Z	3.44	1.56						in
Zn	CMZH054Z	11.02	5.00	mm	300	80	28	180	6 28309 24566 5
				in	11.8	3.15	1.1	7.09	
Zn	CMRF484Z	17.64	8.00	mm	300	150	25	160	6 28309 24481 1
				in	11.8	5.91	1	6.3	

HULL ANODES

HULL ANODES

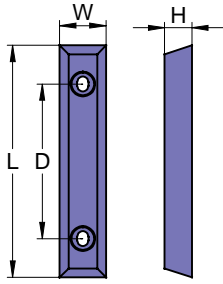

	PID	LB	KG		L	W	H	D	UPC
Zn	CMSH090Z	6.61	3.00	mm	300	60	35.3	200	6 28309 24554 2
				in	11.8	2.36	1.39	7.87	
Zn	CMSH091Z	11.00	5.00	mm	330	80	35	200	6 28309 24555 9
				in	13	3.15	1.38	7.87	
Zn	CMSH125Z	19.84	9.00	mm	440	88	40	230	6 28309 24557 3
				in	17.3	3.46	1.57	9.06	
Zn	CMSH126Z	26.46	12.00	mm	445	92	50	230	6 28309 24558 0
				in	17.5	3.62	1.97	9.06	
Zn	CMSH127Z	30.86	14.00	mm	455	98	55	230	6 28309 24559 7
				in	17.9	3.86	2.17	9.06	

RP SERIES ROUND PLATE ANODES

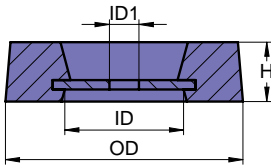

**BOLT-ON
ROUND PLATE**

	PID	LB	KG		H	OD	ID	ID1	UPC
Al	CMRP4A	1.01	0.45	mm	25	100	50	12.5	6 28309 24708 9
Mg	CMRP4M	0.72	0.33						6 28309 24714 0
Zn	CMRP4Z	2.24	1.01	in	0.98	3.94	1.96	0.49	6 28309 24702 7
Al	CMRP5A	1.89	0.86	mm	25.4	125	28	10	6 28309 24709 6
Mg	CMRP5M	1.32	0.6						6 28309 24715 7
Zn	CMRP5Z	4.40	2	in	1	4.92	1.10	0.39	6 28309 24703 4
Al	CMRP6SA	2.45	1.11	mm	25.4	146	32	14.5	6 28309 25675 3
Mg	CMRP6SM	1.67	0.76						6 28309 25676 0
Zn	CMRP6SZ	5.85	2.65	in	1	5.75	1.26	0.57	6 28309 25674 6
Al	CMRP6A	3.59	1.63	mm	38	146	32	14.5	6 28309 24710 2
Mg	CMRP6M	2.39	1.09						6 28309 24716 4
Zn	CMRP6Z	8.82	4	in	1.49	5.75	1.26	0.57	6 28309 24704 1
Al	CMRP7A	3.15	1.43	mm	25	168	40	12	6 28309 24711 9
Mg	CMRP7M	2.08	0.94						6 28309 24717 1
Zn	CMRP7Z	7.83	3.55	in	0.98	6.61	1.57	0.47	6 28309 24705 8
Al	CMRP8A	4.56	2.07	mm	26	197	20	12	6 28309 24712 6
Mg	CMRP8M	2.98	1.35						6 28309 24718 8
Zn	CMRP8Z	11.50	5.22	in	1.02	7.75	0.79	0.47	6 28309 24706 5
Al	CMRP9A	5.87	2.66	mm	25.4	222.3	14	12	6 28309 24713 3
Mg	CMRP9M	3.81	1.73						6 28309 24719 5
Zn	CMRP9Z	14.92	6.77	in	1	8.75	0.55	0.47	6 28309 24707 2

Martyr®
HULL ANODES

ROUND PLATE ANODES

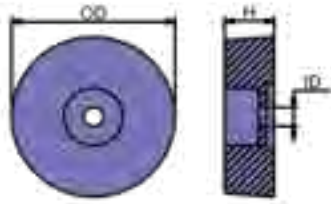

	PID	LB	KG		OD	ID	H	UPC
Al	SGBA001A	2.18	0.99	mm	125	15	38	6 28309 18384 4
Mg	SGBA001M	1.41	0.64					6 28309 18435 3
Zn	SGBA001Z	5.58	2.53	in	4.92	0.59	1.49	6 28309 18335 6
Al	SGBA506A	3.50	1.59	mm	140	16	40	6 28309 18385 1
Mg	SGBA506M	2.45	1.11					6 28309 18523 7
Zn	SGBA506Z	8.14	3.69	in	5.51	0.63	1.57	6 28309 24126 1
Al	SGBA597A	5.11	2.32	mm	200	17	25	6 28309 18386 8
Mg	SGBA597M	3.5	1.60					6 28309 18437 7
Zn	SGBA597Z	11.79	5.35	in	7.87	0.67	0.98	6 28309 18337 0

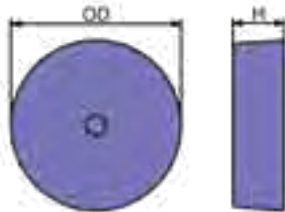

	PID	LB	KG		H	OD	UPC
Al	CMF90BA	0.831	0.377	mm	25	90	6 28309 24207 7
Mg	CMF90BM	0.527	0.239				6 28309 24333 3
Zn	CMF90BZ	2.17	0.984	in	1	3.5	6 28309 24129 2

**NEW
PRODUCTS**

HULL ANODES

PLEASURECRAFT

I N B O A R D /

O U T B O A R D /

S T E R N D R I V E

A N O D E S

BRP™ OMC / JOHNSON EVINRUDE ANODES

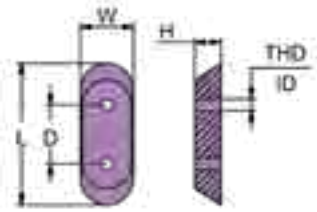

	PID	LB	KG		L	W	H	D	THD	ID	UPC
Al	CM123009A	0.068	0.031	mm	61	23	12	25.4	10-24 UNC	--	6 28309 12670 4
Mg	CM123009M	0.045	0.020								6 28309 11320 9
Zn	CM123009Z	0.185	0.084	in	2.4	0.9	0.45	1			6 28309 11321 6

ENGINES 70-90 HP



	PID	LB	KG		L	W	H	D	THD	ID	UPC
Al	CM327606A	0.068	0.031	mm	61	23	12	25.4	--	5.1	6 28309 12338 3
Mg	CM327606M	0.045	0.020								6 28309 12682 7
Zn	CM327606Z	0.185	0.084	in	2.4	0.9	0.45	1		0.2	6 28309 10014 8

JOHNSON 2-150 HP

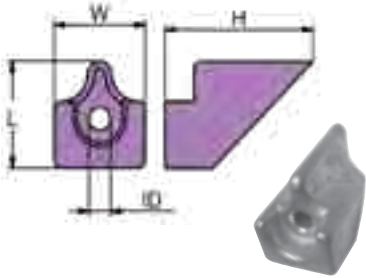

	PID	LB	KG		L	W	H	D	THD	ID	UPC
Al	CM334451A	0.082	0.037	mm	33	29.8	48.5	6.9	--	6.9	6 28309 12338 3
Mg	CM334451M	0.055	0.025								6 28309 17603 7
Zn	CM334451Z	0.213	0.096	in	1.3	1.17	1.91	0.27			6 28309 19249 5

JOHNSON 4 - 7,5 HP EVINRUDE 4 - 7,5 HP

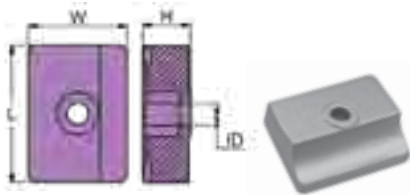

	PID	LB	KG		L	W	H	D	THD	ID	UPC
Al	CM338635A	0.037	0.017	mm	36	26	12.65	6	--	6	6 28309 21146 2
Mg	CM338635M	0.024	0.011								6 28309 21168 4
Zn	CM338635Z	0.099	0.045	in	1.4	1	0.5	0.22			6 28309 21124 0

DOUBLE PLATE OUTBOARD 9,9-15CV

JOHNSON 8 - 9,9 - 15 HP

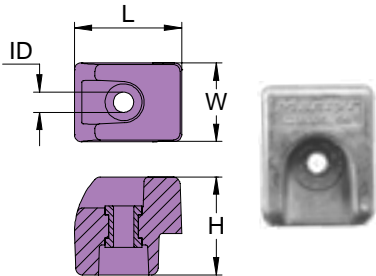

	PID	LB	KG		L	W	H	D	THD	ID	UPC
Al	CM355964A	0.265	0.12	mm	46.6	34.25	42.5	8.15	--	8.15	6 28309 27550 4
Mg	CM355964M	0.176	0.08								6 28309 27562 4
Zn	CM355964Z	0.662	0.3	in	1.83	1.35	1.67	0.32			6 28309 27556 3

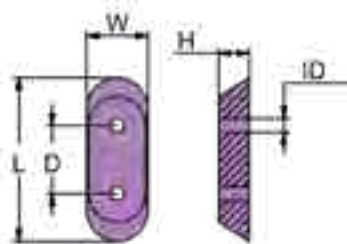

	PID	LB	KG		L	D	W	H	D	THD	ID	UPC
Al	CM357507A	0.062	0.028	mm	61	25.4	22.86	10.92	7.37	--	6.4	6 28309 27550 4
Mg	CM357507M	0.039	0.018									6 28309 27563 1
Zn	CM357507Z	0.162	0.73	in	2.4	1	0.9	0.43	0.29			6 28309 27557 0

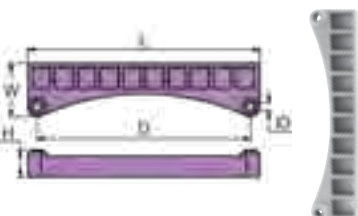

	PID	LB	KG		L	W	H	D	THD	ID	UPC
Al	CM367A	0.368	0.167	mm	193	43	22	179	--	6.4	6 28309 12672 8
Mg	CM367M	0.231	0.105								6 28309 12683 4
Zn	CM367Z	0.954	0.433	in	7.6	1.7	0.87	7.05	0.25		6 28309 10021 6

OMC P

Protect your boat, respect our waters.

NEW PRODUCTS

BRP™ OMC / JOHNSON EVINRUDE ANODES

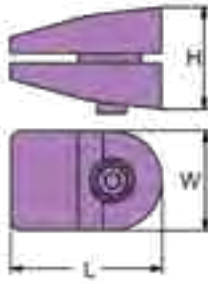

	PID	LB	KG		L	W	H	UPC
Al	CM389999A	0.165	0.075	mm	48	31	32.5	6 28309 24165 0
Mg	CM389999M	0.108	0.049					6 28309 24271 8
Zn	CM389999Z	0.412	0.187	in	1.9	1.23	1.28	6 28309 11322 3

SAILDRIVE

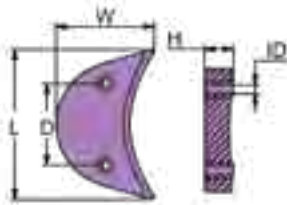

	PID	LB	KG		L	W	H	D	ID	UPC
Al	CM392123A	0.650	0.295	mm	120	76	22	63.5	6.9	6 28309 19256 3
Mg	CM392123M	0.445	0.202							6 28309 19288 4
Zn	CM392123Z	1.684	0.764	in	4.7	3	0.88	2.5	0.27	6 28309 10032 2

OMC 90 - 140 HP JOHNSON 90 - 140 HP EVINRUDE 90 - 140 HP

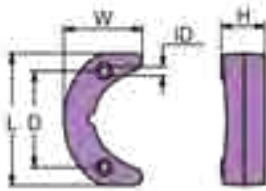

	PID	LB	KG		L	W	H	D	ID	UPC
Al	CM392462A	0.56	0.25	mm	102	64	36	74	6.9	6 28309 12673 5
Mg	CM392462M	0.36	0.16							6 28309 12684 1
Zn	CM392462Z	1.44	0.65	in	4	2.5	1.4	2.9	0.27	6 28309 10034 6

OMC 50 - 75 HP JOHNSON 50 - 75 HP EVINRUDE 50 - 75 HP

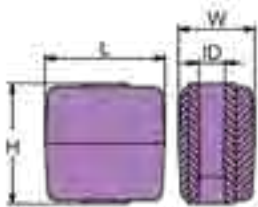

	PID	LB	KG		L	W	H	ID	UPC
Al	CM393023A	0.192	0.087	mm	40	25	41	8.5	6 28309 12674 2
Mg	CM393023M	0.141	0.064						6 28309 12685 8
Zn	CM393023Z	0.445	0.202	in	1.6	1	1.63	0.33	6 28309 10035 3

(SUPERCEDES TO CM436705) OMC 50 - 60 - 70 - 90 - 140 HP JOHNSON 50 - 115 - 120 - 140, HP EVINRUDE 50-140 - 200 HP

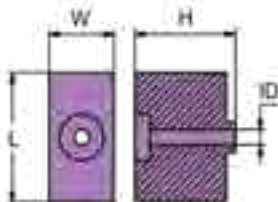
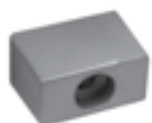

	PID	LB	KG		L	W	H	ID	UPC
Al	CM395780A	0.158	0.072	mm	45	23	33.5	8	6 28309 23338 9
Mg	CM395780M	0.101	0.046						6 28309 23339 6
Zn	CM395780Z	0.412	0.187	in	1.77	0.91	1.3	0.32	6 28309 23340 2

PLATE 60-280HP

BRP™ OMC / JOHNSON EVINRUDE ANODES

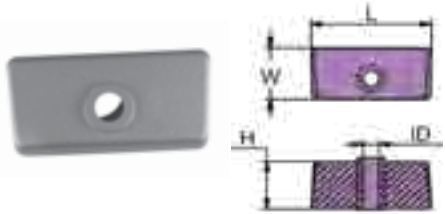

PID		LB	KG		L	W	H	ID	UPC
Al	CM397768A	0.277	0.126	mm	64	31	29.7	30	6 28309 12675 9
Mg	CM397768M	0.187	0.085						6 28309 12686 5
Zn	CM397768Z	0.674	0.306	in	2.5	1.2	1.17	1.18	6 28309 10037 7

OMC COBRA

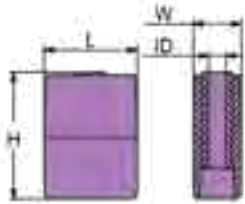

PID		LB	KG		L	W	H	ID	UPC
Al	CM398331A	0.295	0.134	mm	45	23	58.7	8.1	6 28309 12676 6
Mg	CM398331M	0.200	0.091						6 28309 12687 2
Zn	CM398331Z	0.705	0.320	in	1.75	0.9	2.31	0.32	6 28309 10039 1

JOHNSON 160 - 280 HP (v4 - v6) EVINRUDE

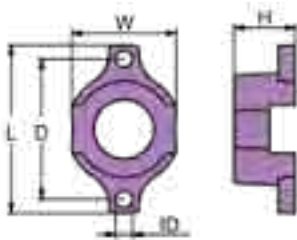

PID		LB	KG		L	W	H	D	ID	UPC
Al	CM398873A	0.132	0.060	mm	76	48	27.9	64.5	7.6	6 28309 12677 3
Mg	CM398873M	0.081	0.037							6 28309 12688 9
Zn	CM398873Z	0.326	0.148	in	3	1.9	1.1	2.54	0.3	6 28309 10041 4

JOHNSON 737

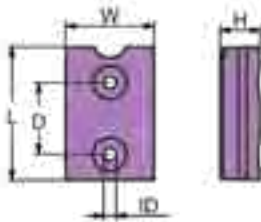

PID		LB	KG		L	W	H	D	ID	UPC
Al	CM431708A	0.231	0.105	mm	75.8	50.8	23	41	6.9	6 28309 12678 0
Mg	CM431708M	0.145	0.066							6 28309 12689 6
Zn	CM431708Z	0.573	0.260	in	3	2	0.9	1.6	0.27	6 28309 10049 0

JOHNSON - EVINRUDE - DIABOLO 70 - 120 HP



PID		LB	KG		L	W	H	UPC
Zn	CM434029Z	0.42	0.19	mm	50	42	24	6 28309 23197 2
				in	2	1.7	0.94	

DOUBLE PLATE

JOHNSON 521 20 - 25 HP 1991 EVINRUDE 20 - 25 HP 1991

Choose
Aluminum

Al premium
SALT AND BRACKISH WATER

Anodes for
salt and brackish
water and
Magnesium

Mg fresh
FRESH WATER ONLY
for freshwater.

BRP™ OMC / JOHNSON EVINRUDE ANODES

	PID	LB	KG		L	W	H	THD	UPC
Al	CM5007089A	0.68	0.31	mm	174.24	34.79	21.33	5/16-18 UNC	6 28309 19257 0
Mg	CM5007089M	0.5	0.22						6 28309 19293 8
Zn	CM5007089Z	1.5	0.68	in	6.86	1.37	0.84		6 28309 11307 0

(CM433580z) JOHNSON - EVINRUDE 60/ 300 HP

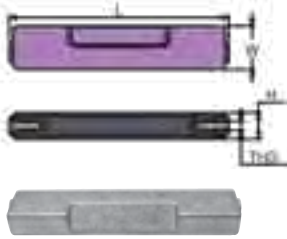
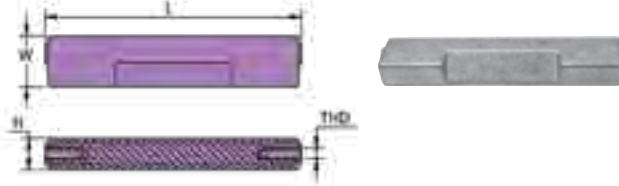

	PID	LB	KG		H	L	W	THD	UPC
Al	CM5008813A	0.672	0.304	mm	21.34	174.24	34.8	M8 X 1.25	6 28309 25539 8
Mg	CM5008813M	0.485	0.22						6 28309 25544 2
Zn	CM5008813Z	1.481	0.672	in	0.84	6.86	1.37		6 28309 25534 3

BRP STERN BRACKET ANODE

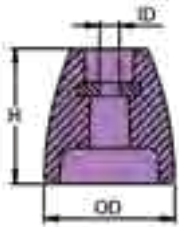

	PID	LB	KG		OD	ID	H	UPC
Al	CM5009138A	0.5	0.23	mm	58	8.8	60	6 28309 25522 0
Mg	CM5009138M	0.33	0.15					6 28309 25527 5
Zn	CM5009138Z	1.28	0.58	in	2.28	0.34	2.36	6 28309 25517 6

BRP PROPELLER SHAFT ANODE

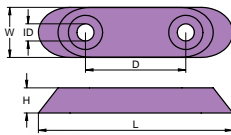

	PID	LB	KG		L	W	H	D	ID	UPC
Al	CM5031538A	0.050	0.023	mm	78	20	10	40	7	6 28309 24169 8
Mg	CM5031538M	0.042	0.019							6 28309 24276 3
Zn	CM5031538Z	0.174	0.079	in	3.1	0.79	0.4	1.6	0.26	6 28309 24103 2

PLATE 2-8 HP

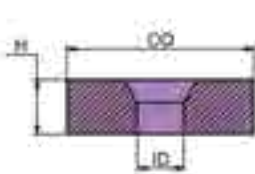

	PID	LB	KG		OD	H	ID	UPC
Zn	CM5031705Z	0.039	0.0175	mm	22	8.5	6.5	6 28309 24104 9
				in	0.87	0.33	0.26	

HONDA 8/20HP

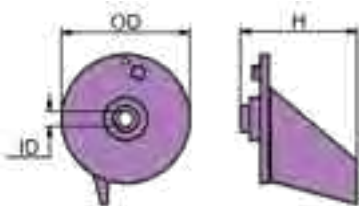

	PID	LB	KG		OD	H	ID	UPC
Al	CM5032929A	0.192	0.087	mm	73	66	9	6 28309 21152 3
Mg	CM5032929M	0.123	0.056					6 28309 21173 8
Zn	CM5032929Z	0.456	0.207	in	2.9	2.6	0.33	6 28309 21128 8

EVINRUDE 70 HP 4T

Martyr®
BRP™ OMC / JOHNSON EVINRUDE ANODES

BRP™ OMC / JOHNSON EVINRUDE ANODES

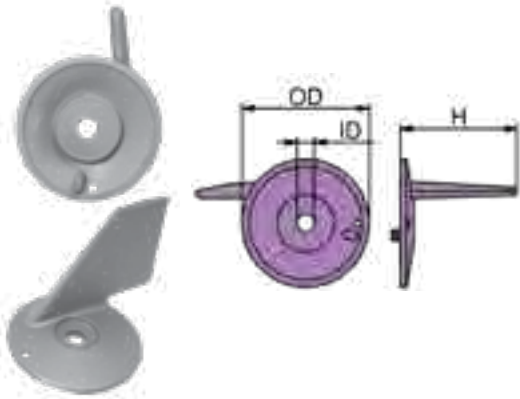

	PID	LB	KG		OD	H	ID	UPC
Al	CM5512595500A	0.150	0.068	mm	62	57	9	6 28309 21153 0
Mg	CM5512595500M	0.095	0.043					6 28309 21174 5
Zn	CM5512595500Z	0.353	0.160	in	2.4	2.24	0.33	6 28309 21129 5

SUZUKI 75 - 85 - 90 HP

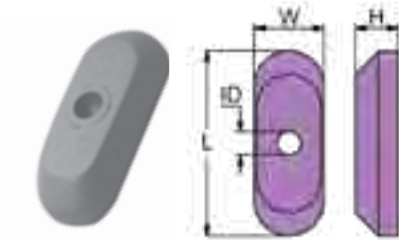

	PID	LB	KG		L	W	H	ID	UPC
Al	CM5532098400A	0.046	0.021	mm	48	18	11	6	6 28309 21154 7
Mg	CM5532098400M	0.028	0.013						6 28309 21175 2
Zn	CM5532098400Z	0.112	0.051	in	1.9	0.7	0.4	0.2	6 28309 21130 1

SUZUKI 2 HP

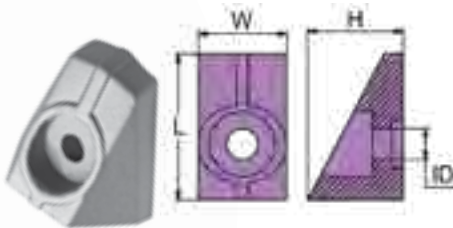

	PID	LB	KG		L	W	H	ID	UPC
Al	CM5532098600A	0.075	0.034	mm	38	39	23	6.4	6 28309 23365 5
Mg	CM5532098600M	0.048	0.022						6 28309 23366 2
Zn	CM5532098600Z	0.196	0.089	in	0.8	1.54	0.9	0.25	6 28309 23367 9

SUZUKI F.B.
5 HP

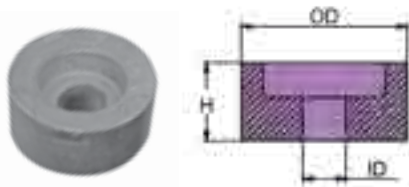

	PID	LB	KG		OD	H	ID	UPC
Al	CM5532187J00A	0.015	0.007	mm	21	10	6	6 28309 12963 7
Mg	CM5532187J00M	0.009	0.004					6 28309 24281 7
Zn	CM5532187J00Z	0.039	0.018	in	0.83	0.39	0.24	6 28309 19252 5

	PID	LB	KG		L	W	H	ID	UPC
Al	CM5532190J01A	0.079	0.036	mm	55	22	19	6	6 28309 21155 4
Mg	CM5532190J01M	0.050	0.023						6 28309 21176 9
Zn	CM5532190J01Z	0.200	0.091	in	2.2	0.9	0.7	0.2	6 28309 21131 8

DF 90 - 115 - 140

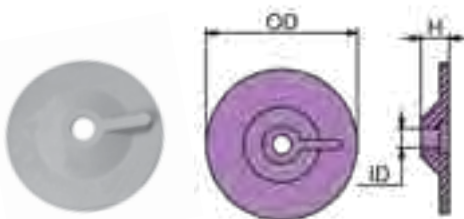

	PID	LB	KG		OD	H	ID	UPC
Al	CM5532193900A	0.046	0.021	mm	48	9	7	6 28309 20956 8
Mg	CM5532193900M	0.028	0.013					6 28309 20935 3
Zn	CM5532193900Z	0.121	0.055	in	1.9	0.4	0.26	6 28309 20977 3

PLATE 9.9-15 HP

BRP™ OMC / JOHNSON EVINRUDE ANODES

BRP™ OMC / JOHNSON EVINRUDE ANODES

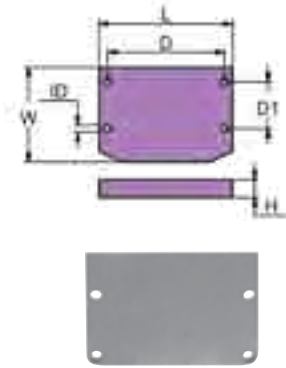

	PID	LB	KG		L	W	H	D	D1	ID	UPC
Al	CM980756A	0.82	0.37	mm	117	80	16	102	41	7	6 28309 24182 7
Mg	CM980756M	0.53	0.24								6 28309 24292 3
Zn	CM980756Z	2.11	0.96	in	4.6	3.2	0.6	4	1.6	0.28	6 28309 10145 9

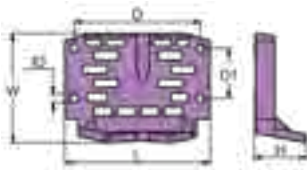

	PID	LB	KG		L	W	H	D	D1	ID	UPC
Al	CM982277A	0.72	0.33	mm	117	85	41	102	41	7	6 28309 24183 4
Mg	CM982277M	0.47	0.21								6 28309 24293 0
Zn	CM982277Z	1.87	0.85	in	4.6	3.33	1.6	4	1.6	0.28	6 28309 10146 6

OMC M (100-245 HP)

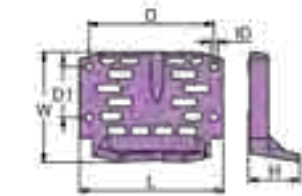

	PID	LB	KG		L	W	H	D	D1	ID	UPC
Zn	CM982438Z	2.67	1.21	mm	176	81	40	102	41	7	6 28309 24115 5
				in	6.9	3.2	1.6	4	1.6	0.28	

OMC 100-245 HP



	PID	LB	KG		L	W	H	D	THD	UPC
Al	CM983494A	0.615	0.279	mm	146	104	25	113	1/4-20 UNC	6 28309 12679 7
Mg	CM983494M	0.415	0.188							6 28309 12690 2
Zn	CM983494Z	1.500	0.680	in	5.72	4.09	0.98	4.44		6 28309 10149 7

OMC 90 HP

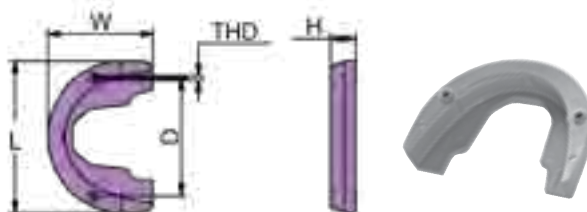

BRP™ OMC / JOHNSON EVINRUDE ANODES

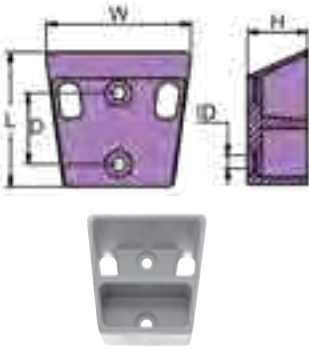

	PID	LB	KG		L	W	H	D	ID	UPC
Al	CM983952A	0.948	0.430	mm	107	112	46.5	57.2	10.5	6 28309 24185 8
Mg	CM983952M	0.619	0.281							6 28309 24295 4
Zn	CM983952Z	2.387	1.083	in	4.2	4.4	1.8	2.25	0.4	6 28309 10150 3

OMC COBRA 130- 385 HP

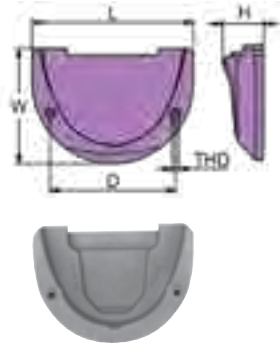

	PID	LB	KG		L	W	H	D	THD	UPC
Al	CM984513A	0.83	0.38	mm	145	104	40.6	113	¼-20 UNC	6 28309 12680 3
Mg	CM984513M	0.59	0.27							6 28309 10152 7
Zn	CM984513Z	2.14	0.97	in	5.7	4.1	1.6	4.44		6 28309 10153 4

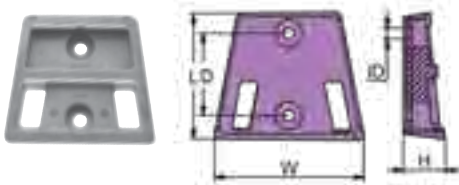

	PID	LB	KG		L	W	H	D	ID	UPC
Al	CM984547A	0.871	0.395	mm	97	115	32	57	10	6 28309 12681 0
Mg	CM984547M	0.584	0.265							6 28309 12691 9
Zn	CM984547Z	2.083	0.945	in	3.8	4.5	1.24	2.25		0.38

OMC COBRA BASSA

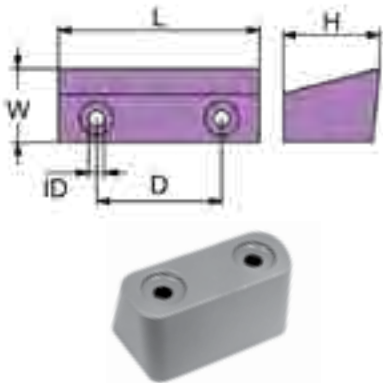

	PID	LB	KG		L	W	H	D	ID	UPC
Al	CM986158A	1.653	0.218	mm	90	45	43	51	10	6 28309 24186 5
Mg	CM986158M	1.067	0.138							6 28309 24296 1
Zn	CM986158Z	3.589	0.568	in	3.5	1.77	1.7	2		0.37

OMC COBRA

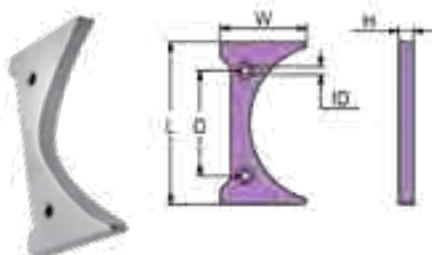

	PID	LB	KG		L	W	H	D	ID	UPC
Al	CM987067A	0.59	0.269	mm	158	84	15	102	8	6 28309 24187 2
Mg	CM987067M	0.37	0.17							6 28309 24297 8
Zn	CM987067Z	1.59	0.72	in	6.2	3.3	0.6	4		0.3

omc5700

BRP™ OMC / JOHNSON EVINRUDE ANODES

Choose
Aluminum

Al premium
SALT AND BRACKISH WATER

Anodes for
salt and brackish
water and
Magnesium

Mg fresh
FRESH WATER ONLY
for freshwater.

Martyr

BRP™ OMC / JOHNSON EVINRUDE ANODES

PLEASE NOTE: KITS IN PICTURES SHOWN IN ALUMINUM ALLOY.
SEE THE CATALOG LISTING FOR ALL ALLOYS AVAILABLE.

BRP™ ANODE KITS



	PID	LB	KG	Contains	Fits	UPC
Al	CMSTRGERKITA	1.4	0.63	CM983494 X 1 CM393023 X 1 CM431708 X 1	BRP OMC Stringer	6 28309 24965 6
Mg	CMSTRGERKITM	1.07	0.48			6 28309 24966 3
Zn	CMSTRGERKITZ	2.95	1.34			6 28309 24982 3

BRP OMC STRINGER



	PID	LB	KG	Contains	Fits	UPC
Al	CMCOBRAKITA	1.65	0.750	CM984513 X 1 CM393023 X 1 CM431708 X 1	BRP OMC COBRA	6 28309 24950 2
Mg	CMCOBRAKITM	1.07	0.484			6 28309 24951 9
Zn	CMCOBRAKITZ	3.59	1.628			6 28309 24952 6

BRP OMC COBRA



	PID	LB	KG	Contains	Fits	UPC
Al	CMOMC5075KITA	1.11	0.50	CM393023 X 1 CM392462 X 1	BRP OMC 50-75HP	6 28309 24956 4
Mg	CMOMC5075KITM	0.89	0.41			6 28309 24957 1
Zn	CMOMC5075KITZ	2.25	1.02			6 28309 24958 8

BRP OMC 50-75HP



	PID	LB	KG	Contains	Fits	UPC
Al	CMOMCV4V6KITA	1.17	0.53	CM393023 X 1 CM392123 X 1	BRP OMC V4-V6	6 28309 24959 5
Mg	CMOMCV4V6KITM	0.93	0.42			6 28309 24960 1
Zn	CMOMCV4V6KITZ	2.45	1.11			6 28309 24961 8

BRP OMC V4-V6



	PID	LB	KG	Contains	Fits	UPC
Al	CMETECG2KITA	2.002	0.917	CM5007089 X 1 CM355964 X 1 CM357507 X 1 CM5009138 X 1	BRP EVINRUDE E-TEC G2	6 28309 27561 7
Mg	CMETECG2KITM	1.473	0.668			6 28309 27564 8
Zn	CMETECG2KITZ	4.430	2.009			6 28309 27558 7

BRP EVINRUDE E-TEC G2

NEW PRODUCTS

BMW™ ANODES

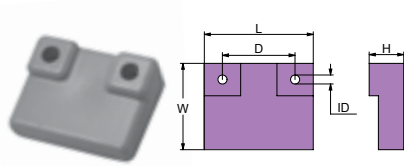

	PID	LB	KG		L	W	H	D	ID	UPC
Zn	CMBW175Z	0.71	0.32	mm	60	48	26	40	8	6 28309 24118 6
				in	2.4	1.9	1	1.6	0.33	

BMW100 MARK1

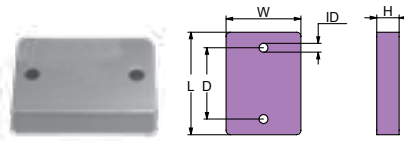

	PID	LB	KG		L	W	H	D	ID	UPC
Zn	CMBW499Z	0.74	0.34	mm	69	50	15	48	6	6 28309 23576 5
				in	2.7	2	0.6	1.9	0.2	

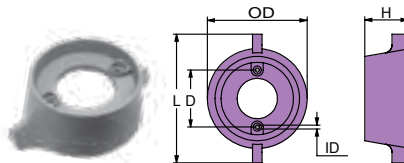

	PID	LB	KG		L	H	D	OD	ID	UPC
Zn	CMBW172Z	1.83	0.83	mm	165	54	80	124	8	6 28309 24651 8
				in	6.5	2.1	3.15	4.9	0.33	

BMW MARK1

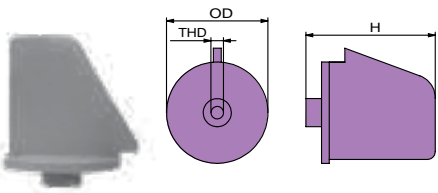

	PID	LB	KG		OD	H	THD	UPC
Zn	CMBW173Z	0.73	0.33	mm	65	83	3/8-16	6 28309 24652 5
				in	2.6	3.3	UNC	

BMW MARK1

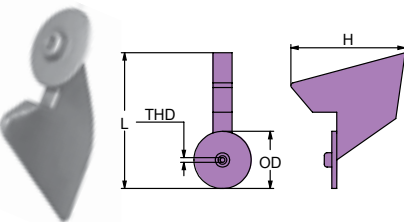

	PID	LB	KG		L	H	OD	THD	UPC
Zn	CMBW043Z	1.5	0.68	mm	165	120	65	3/8-16 UNC	6 28309 23573 4
				in	6.5	4.7	2.56		

BMW MARK2

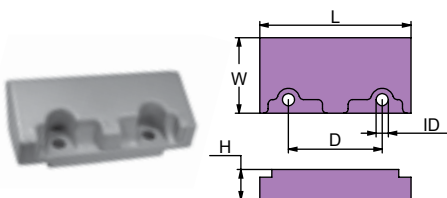

	PID	LB	KG		L	W	H	D	ID	UPC
Zn	CMBW044Z	2.07	0.94	mm	119	59	30	62	9	6 28309 24650 1
				in	4.69	2.32	1.18	2.44	0.33	

BMW MARK2

BMW™ ANODES

BUKH™ ANODES

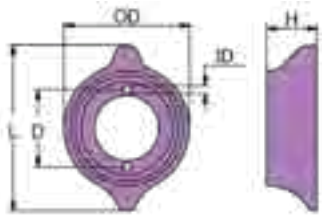

	PID	LB	KG		OD	L	H	D	ID	UPC
Al	CMB00E5829A	0.729	0.330	mm	107	140	43	68	7	6 28309 19260 0
Mg	CMB00E5829M	0.462	0.209							6 28309 19304 1
Zn	CMB00E5829Z	1.900	0.862	in	4.2	5.5	1.7	2.66	0.27	6 28309 12201 0



	PID	LB	KG		OD	L	THD	UPC
Al	CMB00E0450A	0.033	0.015	mm	12	46	M5 x 0.8	6 28309 23559 8
Mg	CMB00E0450M	0.024	0.011					6 28309 23560 4
Zn	CMB00E0450	0.066	0.030	in	0.5	1.8		6 28309 12182 2

CASTOLDI™ ANODES



	PID	LB	KG		OD	H	THD	UPC
Al	CM590140552A	0.086	0.039	mm	22	30	M10 x 1.5	6 28309 21156 1
Mg	CM590140552M	0.072	0.033					6 28309 21156 1
Zn	CM590140552Z	3.185	0.063	in	0.9	1.2		6 28309 21132 5

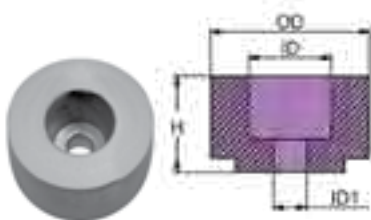

	PID	LB	KG		OD	H	ID	ID1	UPC
Al	CM590163243A	0.43	0.196	mm	58	35	25	9	6 28309 23386 0
Mg	CM590163243M	0.27	0.124						6 28309 23387 7
Zn	CM590163243Z	1.12	0.51	in	2.28	1.38	0.98	0.36	6 28309 23388 4
Al	CM59066209A	0.086	0.039	mm	80	50	30	10.2	6 28309 23389 1
Mg	CM59066209M	0.072	0.033						6 28309 23390 7
Zn	CM59066209Z	3.185	1.445	in	3.15	1.97	1.18	0.4	6 28309 23391 4

HIDEA™ ANODES

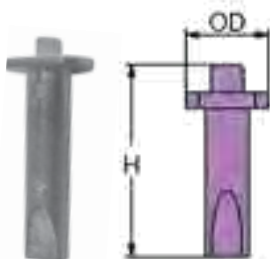

	PID	LB	KG		OD	H	UPC
Al	CM6J81132500A	0.011	0.005	mm	16	41	6 28309 19537 3
Mg	CM6J81132500M	0.006	0.003				6 28309 19538 0
Zn	CM6J81132500Z	0.028	0.013	in	0.63	1.61	6 28309 19539 7

ALSO APPLY TO PAINIER

Martyr®
BUKH™ / CASTOLDI™ / HIDEA™ ANODES

HONDA™ ANODES

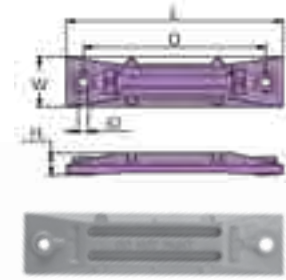

	PID	LB	KG		L	W	H	D	ID	UPC
Al	CM06411ZV5A	0.31	0.14	mm	150	36	16	126	7	6 28309 17552 8
Mg	CM06411ZV5M	0.2	0.09							6 28309 17043 1
Zn	CM06411ZV5Z	0.79	0.36	in	5.9	1.4	0.6	4.9	0.3	6 28309 11373 5

40/50 HP



	PID	LB	KG		L	W	H	D	ID	UPC
Al	CM06411ZW1A	0.70	0.32	mm	226	50	16	202	7	6 28309 17554 2
Mg	CM06411ZW1M	0.44	0.20							6 28309 17041 7
Zn	CM06411ZW1Z	1.81	0.82	in	8.8	2	0.6	7.9	0.3	6 28309 11374 2

75 / 130 / 225 HP



	PID	LB	KG		OD	ID	ID1	H	UPC
Al	CM12155ZW5000A	0.0256	0.0116	mm	24	7	14	14	6 28309 26268 6
Mg	CM12155ZW5000M	0.0164	0.00743						6 28309 26269 3
Zn	CM12155ZW5000Z	0.0672	0.0305	in	0.94	0.28	0.55	0.55	6 28309 26270 9

75 / 90 / 130 HP

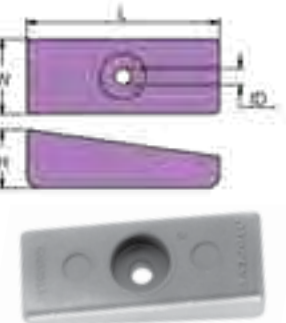

	PID	LB	KG		L	W	H	ID	UPC
Al	CM41109ZW1003A (CM826134A)	0.209	0.095	mm	76	30	23	6	6 28309 24168 1
Mg	CM41109ZW1003M (CM826134M)	0.130	0.059						6 28309 24274 9
Zn	CM41109ZW1003Z (CM826134Z)	0.542	0.246	in	3	1.16	0.9	0.24	6 28309 24102 5

75 HP - v6 40/50 /115 EFI 4T

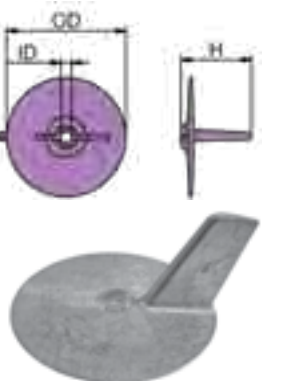

	PID	LB	KG		OD	H	ID	UPC
Al	CM6644537101A	0.238	0.108	mm	96	57	9	6 28309 12643 8
Mg	CM6644537101M	0.154	0.070					6 28309 10064 3
Zn	CM6644537101Z	0.639	0.290	in	3.8	2.2	0.33	6 28309 10065 0

MARINER 10 - 50 HP YAMAHA 20 - 25 - 30 - 40 - 50 HP

HONDA™ ANODES

Choose
Aluminum

Al premium
SALT AND BRACKISH WATER

Anodes for
salt and brackish
water and
Magnesium

Mg fresh
FRESH WATER ONLY
for freshwater.

HONDA™ ANODES

	PID	LB	KG		OD	H	H1	ID	UPC
Al	CM41107ZV500A	0.258	0.117	mm	95	68	59	8	6 28309 12723 7
Mg	CM41107ZV500M	0.156	0.071						6 28309 19291 4
Zn	CM41107ZV500Z	0.668	0.303	in	3.74	2.68	2.33	0.33	6 28309 17045 5

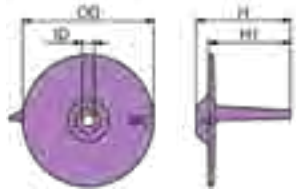
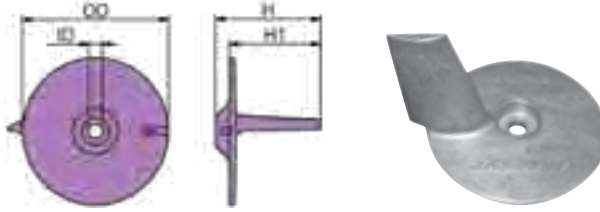

	PID	LB	KG		OD	H	H1	ID	UPC
Al	CM41107ZW1B01ZA	0.427	0.194	mm	112	75	62	9	6 28309 12726 8
Mg	CM41107ZW1B01M	0.273	0.124						6 28309 19292 1
Zn	CM41107ZW1B01Z	1.109	0.503	in	4.4	2.9	2.4	0.33	6 28309 19251 8

HONDA 75 - 90 - 115 -130 HP

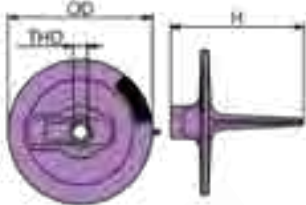

	PID	LB	KG		OD	H	THD	UPC
Al	CM41107ZW1003A	0.460	0.208	mm	92	84	7/16 - 14 UNC	6 28309 24167 4
Mg	CM41107ZW1003M	0.300	0.136					6 28309 24273 2
Zn	CM41107ZW1003Z	1.210	0.549	in	3.6	3.3		6 28309 24101 8

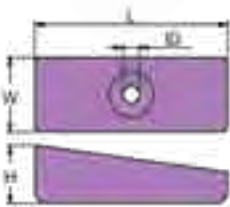

	PID	LB	KG		L	W	H	ID	UPC
Al	CM41109ZW1B00A	0.194	0.088	mm	71	36	17	6	6 28309 12721 3
Mg	CM41109ZW1B00M	0.123	0.056						6 28309 17044 8
Zn	CM41109ZW1B00Z	0.485	0.220	in	2.8	1.4	0.7	0.24	6 28309 12735 0

HONDA 75 - 130 - 225 HP



Martyr
HONDA™ ANODES

HONDA™ ANODES

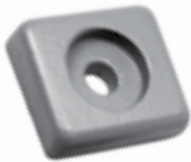
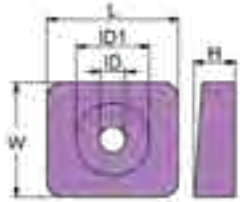
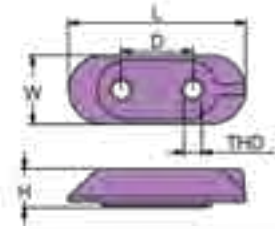

	PID	LB	KG		L	W	H	D	THD	UPC
Al	CM6E04525111A	0.086	0.039	mm	64	25	14	26	M6 x 1	6 28309 12647 6
Mg	CM6E04525111M	0.055	0.025							6 28309 12648 3
Zn	CM6E04525111Z	0.209	0.095	in	2.5	1	0.5	1		6 28309 10069 8

	PID	LB	KG		L	W	H	ID	ID1	UPC
Al	CM41106ZW9000A	0.039	0.018	mm	32	28	10	6	18	6 28309 21151 6
Mg	CM41106ZW9000M	0.026	0.012							6 28309 21172 1
Zn	CM41106ZW9000Z	0.101	0.046	in	1.3	1.1	0.4	0.2	0.7	6 28309 21127 1

HONDA 8 - 10 -15 HP

HONDA™ ANODE KITS

PLEASE NOTE: KITS IN PICTURES SHOWN IN ALUMINUM ALLOY.
SEE THE CATALOG LISTING FOR ALL ALLOYS AVAILABLE.



	PID	LB	KG	Contains	Fits	UPC
Al	CMHBF75115KITA	1.76	0.8	CM41107ZW1B01 X1 CM0641ZW1 X1 CM41109ZW1B00 X2	Honda BF75- 90-115	6 28309 24953 3
Mg	CMHBF75115KITM	1.31	0.59			6 28309 24954 0
Zn	CMHBF75115KITZ	4.27	1.94			6 28309 24955 7



	PID	LB	KG	Contains	Fits	UPC
Al	CMHBF4050KITA	1.305	0.592	CM41107ZV500 X 1 CM06411ZV5 X 1 CM41109ZW1003 / CM826134 X 2	Honda BF40-50HP OB-Motor	6 28309 26007 1
Mg	CMHBF4050KITM	0.959	0.435			6 28309 26029 3
Zn	CMHBF4050KITZ	2.707	1.228			6 28309 25983 9



	PID	LB	KG	Contains	Fits	UPC
Al	CMHBF35225KITA	1.384	0.628	CM41107ZV500 X 1 CM06411ZV5 X 1 CM41109ZW1003 / CM826134 X 2 CM5532187J00 X 2	Honda BF35-225 Motor	6 28309 26006 4
Mg	CMHBF35225KITM	1.014	0.460			6 28309 26028 6
Zn	CMHBF35225KITZ	2.84	1.288			6 28309 25982 2

HONDA™ ANODES

KAMEWA™ ANODES

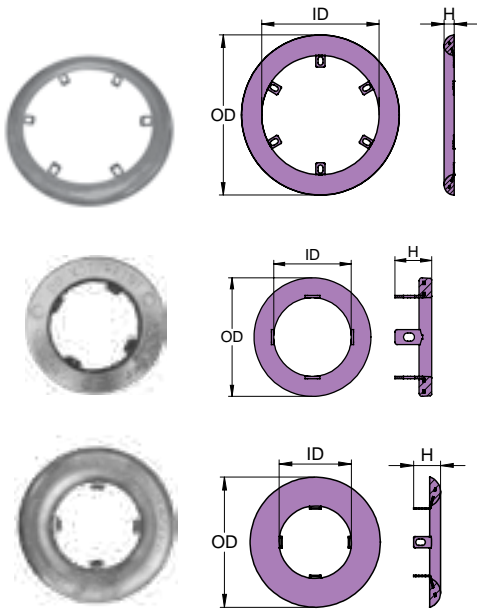

	PID	LB	KG		OD	ID	H	UPC
Al	CMKA614A	6.19	2.81	mm	385	287	25	6 28309 21172 1
Mg	CMKA614M	4.01	1.82					6 28309 23683 0
Zn	CMKA614Z	16	7.3					6 28309 23684 7
Al	CMKA615A	1.23	0.56	mm	160	106	50	6 28309 23685 4
Mg	CMKA615M	0.86	0.39					6 28309 23686 1
Zn	CMKA615Z	2.86	1.3					6 28309 23687 8
Al	CMKA616A	2.456	1.114	mm	226	126	47	6 28309 23688 5
Mg	CMKA616M	1.609	0.730					6 28309 23689 2
Zn	CMKA616Z	6.170	2.799					6 28309 23690 8

JET FF 375S - CLASS V2000

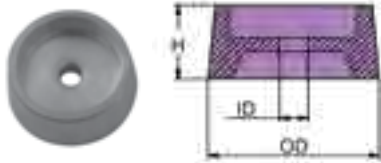

	PID	LB	KG		OD	ID	H	UPC
Al	CMKA617A	0.333	0.151	mm	70	13	27	6 28309 23691 5
Mg	CMKA617M	0.211	0.096					6 28309 23692 2
Zn	CMKA617Z	0.862	0.391					6 28309 23693 9
Al	CMKA730A	0.712	0.323	mm	79	17	42	6 28309 23709 7
Mg	CMKA730M	0.449	0.204					6 28309 23710 3
Zn	CMKA730Z	1.856	0.842					6 28309 23711 0

JET FF 375S - CLASS V2000

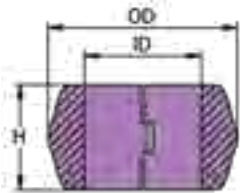

	PID	LB	KG		OD	ID	H	UPC
Al	CMKA618A	0.62	0.28	mm	81	50	45	6 28309 23694 6
Mg	CMKA618M	0.39	0.18					6 28309 23695 3
Zn	CMKA618Z	1.59	0.72					6 28309 22086 0
Al	CMKA619A	0.81	0.37	mm	93	60	48	6 28309 23697 7
Mg	CMKA619M	0.53	0.24					6 28309 23698 4
Zn	CMKA619Z	2.09	0.95					6 28309 23699 1

A SERIES

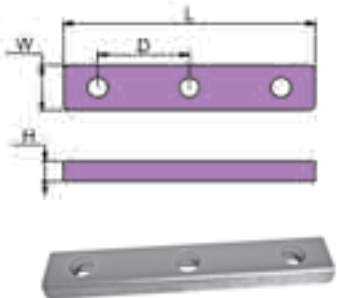

	PID	LB	KG		L	W	D	H	UPC
Al	CMKA620A	4.91	2.23	mm	385	68	140	30	6 28309 22929 0
Mg	CMKA620M	3.73	1.69						6 28309 22960 3
Zn	CMKA620Z	10.14	4.60						6 28309 22927 6
Al	CMKA621A	10.54	4.78	mm	600	100	220	37	6 28309 23700 4
Mg	CMKA621M	7.05	3.2						6 28309 23701 1
Zn	CMKA621Z	25.794	11.700						6 28309 23702 8

KAMEWA TYPE

Martyr®
KAMEWA™ ANODES

KAMEWA™ ANODES

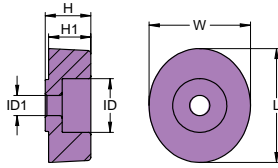

	PID	LB	KG		L	W	H	H1	ID	ID1	UPC
Al	CMKA622A	0.372	0.169	mm	68	60	27	25	32	12	6 28309 23703 5
Mg	CMKA622M	0.236	0.107		6 28309 23704 2						
Zn	CMKA622Z	0.970	0.440	in	2.7	2.4	1.1	1	1.3	0.48	6 28309 22087 7

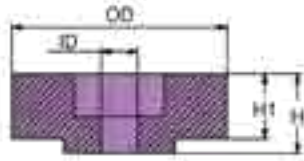

	PID	LB	KG		OD	ID	H	H1	UPC
Al	CMKA623A	0.372	0.278	mm	77	12	25	23	6 28309 23706 6
Mg	CMKA623M	0.236	0.176		6 28309 23707 3				
Zn	CMKA623Z	0.970	0.725	in	3	0.48	0.98	0.9	6 28309 22088 4

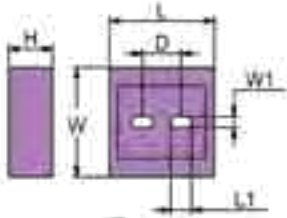

	PID	LB	KG		L	L1	W	W1	D	H	UPC
Al	CMKA624A	0.39	0.176	mm	60	12	60	7	18	25	6 28309 23067 8
Mg	CMKA624M	0.24	0.112		6 28309 23083 8						
Zn	CMKA624Z	1	0.46	in	2.4	0.47	2.4	0.28	0.71	1	6 28309 23051 7

JET FF 375s - CLASS v2000

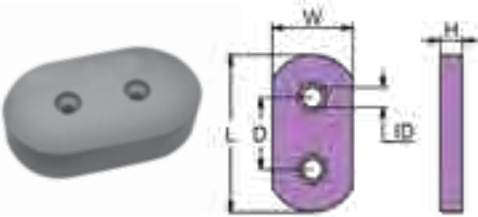

	PID	LB	KG		L	W	H	D	ID	UPC
Al	SGPL573A	2.220	1.007	mm	175	90	25	80	13	6 28309 18342 4
Mg	SGPL573M	1.547	0.702		6 28309 18393 6					
Zn	SGPL573Z	5.081	2.305	in	6.9	3.54	1	3.15	0.51	6 28309 18292 2

LOMBARDINI™ ANODES

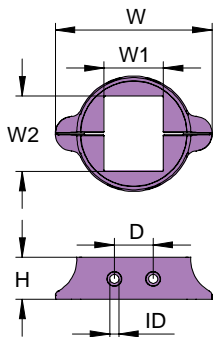

	PID	LB	KG		H	W	W1	W2	D	ID	UPC
Al	CM9135033A	0.524	0.238	mm	33	121	46	59	30	7	6 28309 21162 2
Mg	CM9135033M	0.330	0.150		6 28309 21184 4						
Zn	CM9135033Z	1.366	0.620	in	1.30	4.76	1.81	2.32	1.18	0.27	6 28309 21138 7
Al	CM9135034A	0.974	0.442	mm	33	152	46	59	30	7	6 28309 21163 9
Mg	CM9135034M	0.617	0.280		6 28309 21186 8						
Zn	CM9135034Z	2.542	1.153	in	1.30	5.98	1.81	2.32	1.18	0.27	6 28309 21139 4

KAMEWA™ / LOMBARDINI™ ANODES

Choose
Aluminum

Al premium
SALT AND BRACKISH WATER

Anodes for
salt and brackish
water and
Magnesium

Mg fresh
FRESH WATER ONLY
for freshwater.

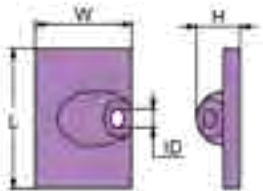
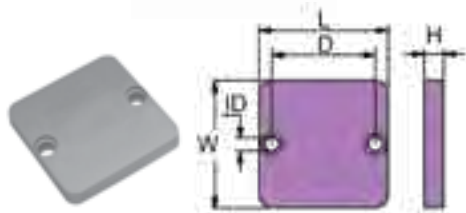
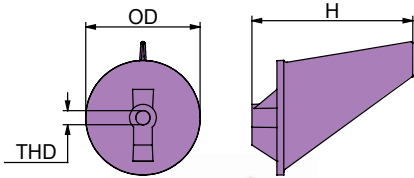
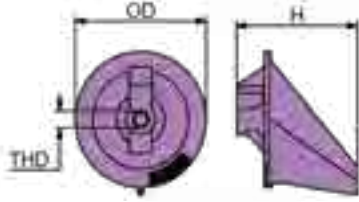
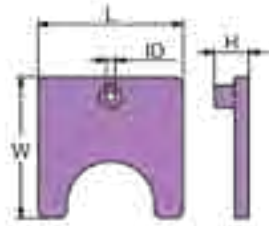

MERCURY™ / MERCUISER™ ANODES

	PID	LB	KG		L	W	H	ID	UPC
Al	CM09411A	0.035	0.016	mm	50	50	12	7	6 28309 23323 5
Mg	CM09411M	0.022	0.010						6 28309 23324 2
Zn	CM09411Z	0.094	0.043	in	2	2	0.5	0.27	6 28309 23325 9

MERCURY 4,5-7 HP

	PID	LB	KG		OD	H	THD	UPC
Al	CM31640A	0.46	0.21	mm	92	84	7/16 - 14 UNC	6 28309 11548 7
Mg	CM31640M	0.3	0.14					6 28309 10010 0
Zn	CM31640Z	1.21	0.55	in	3.6	3.3		6 28309 10011 7

MERCURY 50HP

	PID	LB	KG		OD	H	THD	UPC
Al	CM34127A	0.49	0.22	mm	90.4	127	7/16 - 14 UNC	6 28309 12698 8
Mg	CM34127M	0.32	0.15					6 28309 19284 6
Zn	CM34127Z	1.3	0.59	in	3.56	5		6 28309 10019 3

MERCUISER 80 - 140 HP

	PID	LB	KG		L	W	H	D	ID	UPC
Al	CM34762A	0.207	0.094	mm	64	64	10	51	6	6 28309 12697 1
Mg	CM34762M	0.132	0.059							6 28309 19285 3
Zn	CM34762Z	0.540	0.245	in	2.5	2.5	0.38	2	0.25	6 28309 10020 9

	PID	LB	KG		L	W	H	ID	UPC
Al	CM42121A	0.024	0.011	mm	42	29	11	7	6 28309 20954 4
Mg	CM42121M	0.015	0.007						6 28309 20975 9
Zn	CM42121Z	0.059	0.027	in	1.66	1.1	0.42	0.28	6 28309 20933 9

MERCURY 6-9.9 HP

Martyr®
MERCURY™ / MERCUISER™ ANODES

MERCURY™ / MERCURISER™ ANODES

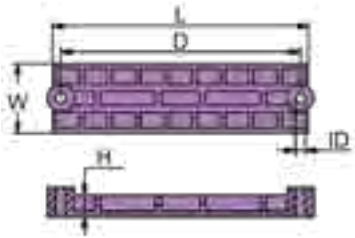

	PID	LB	KG		L	W	H	D	ID	UPA
Al	CM43396A	0.55	0.25	mm	192	52	15.7	178	7.4	6 28309 12694 0
Mg	CM43396M	0.34	0.15							6 28309 24275 6
Zn	CM43396Z	1.45	0.66	in	7.56	2	0.6	7	0.29	6 28309 10051 3

MERCURY 25 HP /50/60/75 - MERCURISER E.B. 90 /
100 SINO 91 115/190 - SUPERAMERICA 80/115

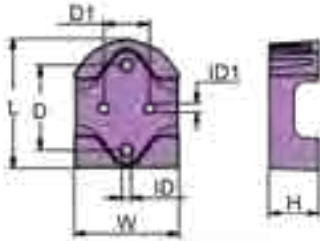
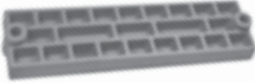

	PID	LB	KG		L	W	H	D	D1	ID	ID1	UPC
Al	CM43994A	0.813	0.369	mm	101	79	38	66	34.5	7	7	6 28309 12696 4
Mg	CM43994M	0.516	0.234									6 28309 10053 7
Zn	CM43994Z	2.121	0.962	in	4	3.1	1.5	2.6	1.36	0.28	0.26	6 28309 10054 4

MERCURY F.BB - MERCURISER E.B. / ALPHA GEN 2 + BRAVO

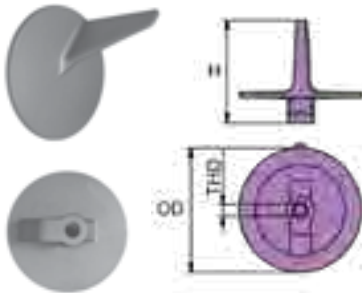

	PID	LB	KG		OD	H	THD	UPC
Al	CM46399A	0.311	0.141	mm	90.4	82.3	7/16 - 14 UNC	6 28309 12695 7
Mg	CM46399M	0.196	0.089					6 28309 19294 5
Zn	CM46399Z	0.807	0.366	in	3.56	3.24		6 28309 10055 1

50 - 140 HP

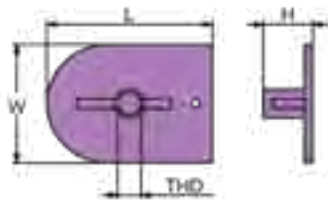

	PID	LB	KG		L	W	H	THD	UPC
Al	CM47820A1A	0.275	0.125	mm	97	74	30	5/16 - 18 UNC	6 28309 23350 1
Mg	CM47820A1M	0.174	0.079						6 28309 23351 8
Zn	CM47820A1Z	0.716	0.325	in	3.82	2.9			1.2

OUTBOARD 20 HP

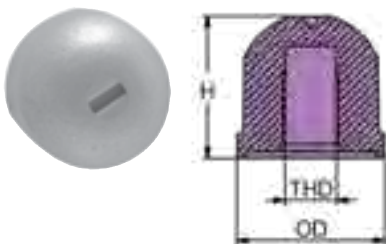

	PID	LB	KG		OD	H	THD	UPC
Al	CM55989A	0.090	0.041	mm	31	30	½ - 13 UNC	6 28309 11540 1
Mg	CM55989M	0.057	0.026					6 28309 10061 2
Zn	CM55989Z	0.225	0.102	in	1.2	1.2		6 28309 10062 9

Protect your boat, respect our waters.

MERCURY™ / MERCUISER™ ANODES

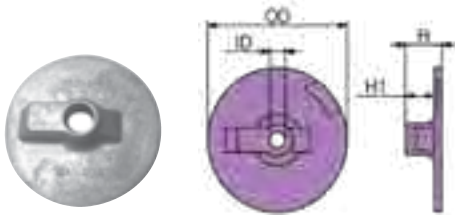

	PID	LB	KG		OD	ID	H	H1	UPC
Al	CM762144A	0.25	0.115	mm	91.95	12.7	23.88	19.05	6 28309 12316 1
Mg	CM762144M	0.16	0.073						6 28309 12314 7
Zn	CM762144Z	0.66	0.3	in	3.62	0.5	0.94	0.75	6 28309 12315 4

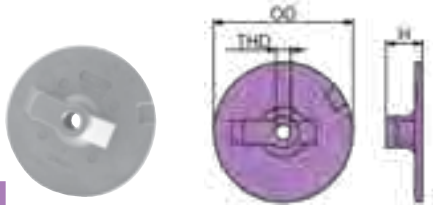

	PID	LB	KG		OD	H	THD	UPC
Al	CM762145A	0.244	0.111	mm	92	24	7/16	6 28309 11542 5
Mg	CM762145M	0.163	0.074				- 14	6 28309 12310 9
Zn	CM762145Z	0.652	0.296	in	3.6	0.9	UNC	6 28309 11368 1

MERCURY ALPHA

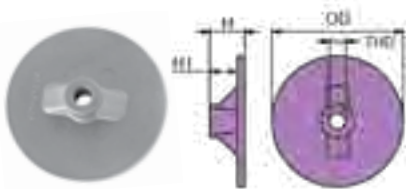

	PID	LB	KG		OD	H	H1	THD	UPC
Al	CM76214A	0.238	0.108	mm	90	24	19	7/16	6 28309 15937 5
Mg	CM76214M	0.149	0.068					- 14	6 28309 11323 0
Zn	CM76214Z	0.593	0.269	in	3.54	0.94	0.75	UNC	6 28309 10085 8

VERADO AND BRAVO

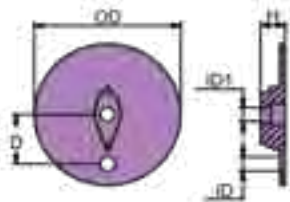

	PID	LB	KG		OD	ID	H	D	ID1	UPC
Al	CM76214Q5A	0.289	0.131	mm	112	11.2	19	39	11	6 28309 21160 8
Mg	CM76214Q5M	0.185	0.084							6 28309 21181 3
Zn	CM76214Q5Z	0.732	0.332	in	4.4	0.44	0.7	1.54	0.43	6 28309 21136 3

BRAVO4 225-250 HP

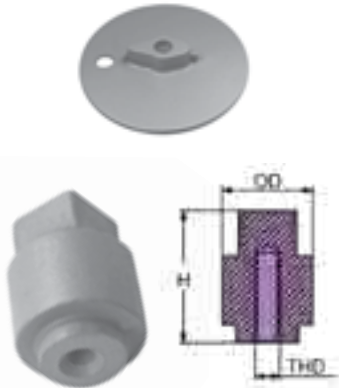

	PID	LB	KG		OD	H	THD	UPC
Al	CM804079002A	0.055	0.025	mm	22	32	M6 x 1	6 28309 21161 5
Mg	CM804079002M	0.035	0.016					6 28309 21182 0
Zn	CM804079002Z	0.123	0.056	in	0.9	1.3		6 28309 21137 0

YAMAHA 80 - 90 -100 -115 -200 - 225 -250 -300 HP

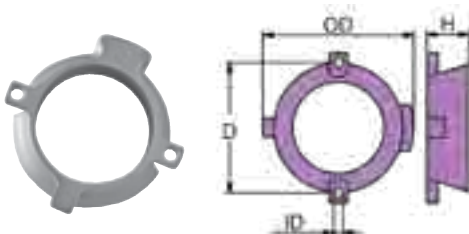

	PID	LB	KG		OD	ID	H	D	UPC
Al	CM806105A	0.192	0.087	mm	85	5	24	74	6 28309 11545 6
Mg	CM806105M	0.121	0.055						6 28309 11497 8
Zn	CM806105Z	0.476	0.216	in	3.3	0.2	0.9	2.9	6 28309 10089 6

MERCUISER ALPHA ONE - ALPHA 2 GEN.

MERCURY™ / MERCRUISER™ ANODES

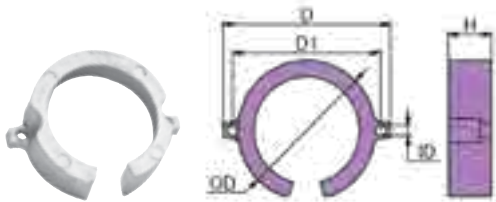

	PID	LB	KG		OD	ID	D	D1	H	UPC
Al	CM806188A	0.132	0.060	mm	70	5	84	74	23	6 28309 11537 1
Mg	CM806188M	0.088	0.040							6 28309 12258 4
Zn	CM806188Z	0.330	0.150	in	2.75	0.2	3.3	2.91	0.9	6 28309 11520 3

BRAVO 1 AND BRAVO 3

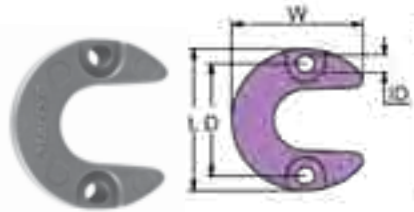

	PID	LB	KG		L	W	H	D	ID	UPC
Al	CM806189A	0.086	0.039	mm	49	44	14	38	5	6 28309 11538 8
Mg	CM806189M	0.057	0.026							6 28309 10095 7
Zn	CM806189Z	0.222	0.101	in	1.9	1.7	0.5	1.5	0.2	6 28309 10096 4

PISTONS MERCRUISER ALPHA

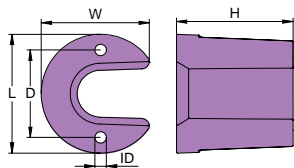

	PID	LB	KG		L	W	H	D	ID	UPC
Al	CM806190A	0.289	0.131	mm	52	46	51	38	5	6 28309 11541 8
Mg	CM806190M	0.183	0.083							6 28309 11496 1
Zn	CM806190Z	0.749	0.340	in	2.047	1.8	0.2	1.5	0.197	6 28309 10099 5

PISTONS MERCRUISER BRAVO

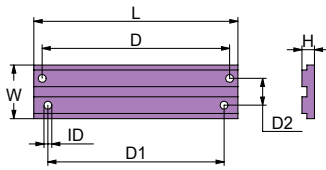

	PID	LB	KG		L	W	H	D	D1	D2	ID	UPC
Al	CM818298A	0.582	0.264	mm	194	51	12	178	167	25	7	6 28309 11547 0
Mg	CM818298M	0.386	0.175									6 28309 12313 0
Zn	CM818298Z	1.510	0.685	in	7.62	2.00	0.47	7.00	6.58	1.00	0.27	6 28309 10020 9

40 HP A V6 135/ 150 /175 VERADO

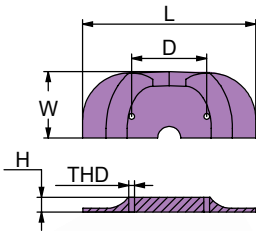

	PID	LB	KG		L	W	H	D	THD	UPC
Al	CM821629CA	0.66	0.3	mm	191	73	16	83	¼ - 20 UNC	6 28309 11546 3
Mg	CM821629CM	0.44	0.2							6 28309 11379 7
Zn	CM821629CZ	1.72	0.78	in	7.5	2.88	0.64	3.25		6 28309 10110 7

ALPHA ONE - ALPHA 2 GEN.

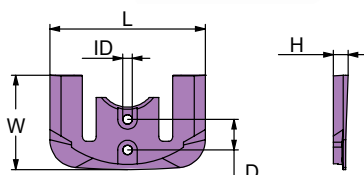

	PID	LB	KG		L	W	H	D	ID	UPC
Al	CM821630C2A	0.86	0.39	mm	178	108	14	35	11	6 28309 11539 5
Mg	CM821630C2M	0.57	0.26							6 28309 11498 5
Zn	CM821630C2Z	2.2	1	in	7	4.25	0.56	1.38	0.44	6 28309 10113 8

BRAVO 1 / 2 / 3



MERCURY™ / MERCRUISER™ ANODES

Choose Aluminum

Al premium
SALT AND BRACKISH WATER

Anodes for salt and brackish water and Magnesium

Mg fresh
FRESH WATER ONLY
for freshwater.

MERCURY™ / MERCUISER™ ANODES

	PID	LB	KG		L	W	H	D	ID	UPC
Al	CM821631A	0.750	0.340	mm	102	76	38	35	7	6 28309 11549 4
Mg	CM821631M	0.498	0.226							6 28309 10053 7
Zn	CM821631Z	1.96	0.89	in	4	3	1.5	1.38	0.27	6 28309 10054 4

MERCURY F.BB - MERCUISER E.B.

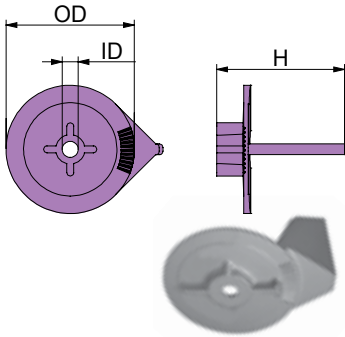
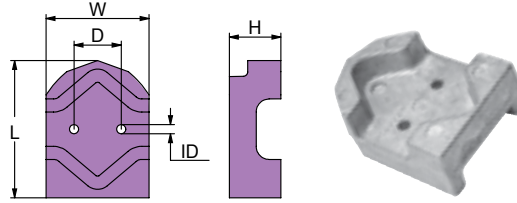

	PID	LB	KG		OD	ID	H	UPC
Al	CM822157C2A	0.390	0.177	mm	93	9	82	6 28309 19598 4
Mg	CM822157C2M	0.247	0.112					6 28309 19601 1
Zn	CM822157C2Z	1.014	0.460	in	3.65	0.36	3.2	6 28309 11371 1

F25- F50

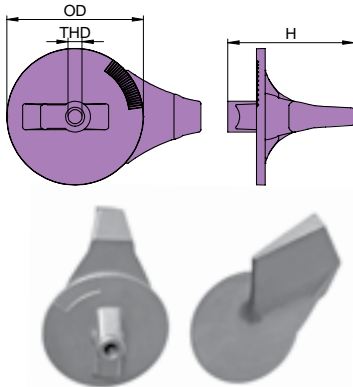

	PID	LB	KG		OD	H	THD	UPC
Al	CM822777A	0.650	0.295	mm	91.4	83.8	7/16 - 14	6 28309 24179 7
Mg	CM822777M	0.412	0.187					6 28309 24289 3
Zn	CM822777Z	1.697	0.770	in	3.6	3.3	UNC	6 28309 24112 4

35 HP - V6 MCM

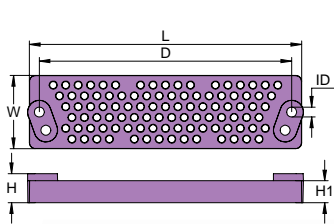

	PID	LB	KG		L	W	H	H1	D	ID	UPC
Al	CM8239121A	0.716	0.325	mm	192	52	20	16	178	7	6 28309 23494 2
Mg	CM8239121M	0.452	0.205								6 28309 23495 9
Zn	CM8239121Z	1.867	0.847	in	7.56	2.05	0.79	0.63	7.01	0.27	6 28309 23496 6

MERCURY 50-75 HP MERCUISER 90-100 HP
SUPER AMERICA 80-155 HP
NISSAN - TOHATSU 4,5 HP

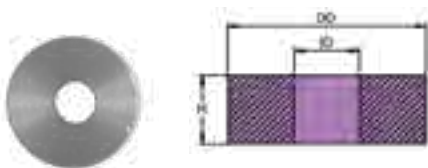

	PID	LB	KG		OD	H	ID	UPC
Al	CM823912A	0.011	0.005	mm	20.06	7.11	6.60	6 28309 23497 3
Mg	CM823912M	0.006	0.003					6 28309 23498 0
Zn	CM823912Z	0.031	0.014	in	0.79	0.28	0.26	6 28309 23499 7

Martyr®
MERCURY™ / MERCUISER™ ANODES

MERCURY™ / MERCURISER™ ANODES

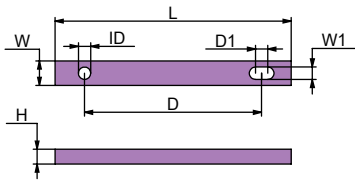

	PID	LB	KG		L	W	W1	H	D	D1	ID	UPC
Al	CM825271A	0.247	0.112	mm	193	19	6	12	167	8	6.9	6 28309 20958 2
Mg	CM825271M	0.156	0.071									6 28309 20979 7
Zn	CM825271Z	0.617	0.280	in	7.6	0.75	0.25	0.5	6.58	0.32	0.27	6 28309 20937 7



25-30-40 HP 4T

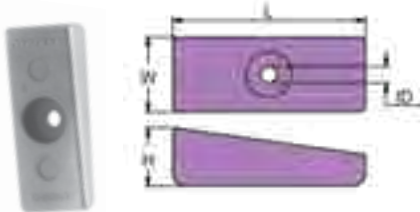

	PID	LB	KG		L	W	H	ID	UPC
Al	CM826134A	0.209	0.095	mm	76	30	23	6	6 28309 11543 2
Mg	CM826134M	0.130	0.059						6 28309 12354 3
Zn	CM826134Z	0.542	0.246	in	3	1.16	0.9	0.25	6 28309 10123 7

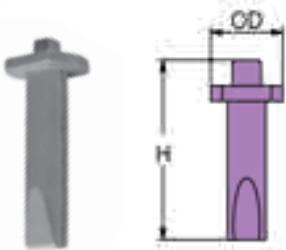

	PID	LB	KG		OD	H	UPC
Al	CM826887MA	0.011	0.005	mm	16	40	6 28309 24180 3
Mg	CM826887MM	0.006	0.003				6 28309 24290 9
Zn	CM826887MZ	0.028	0.013	in	0.6	1.6	6 28309 24113 1

ALSO APPLY TO YAMAHA, PARSUN

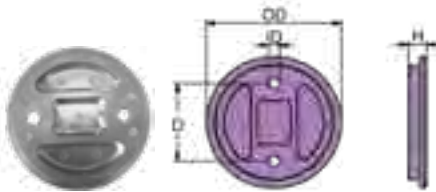

	PID	LB	KG		OD	ID	H	D	UPC
Al	CM847635001A	0.853	0.387	mm	129.28	10.41	17.52	76.2	6 28309 25542 8
Mg	CM847635001M	0.540	0.245						6 28309 25547 3
Zn	CM847635001Z	2.222	1.008	in	5.09	0.41	0.69	3	6 28309 25537 4

MERCURY RACING OB TRIM; VERADO 350 CI - 6 CYLINDER - 4 TIMES

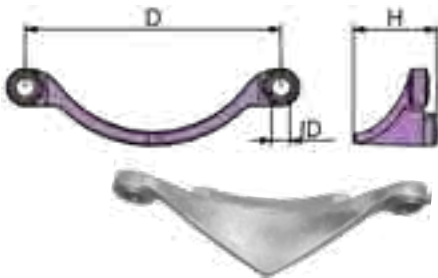

	PID	LB	KG		ID	D	H	UPC
Al	CM856581CA	0.253	0.115	mm	11.17	152.4	49.82	6 28309 25996 9
Mg	CM856581CM	0.174	0.079					6 28309 26020 0
Zn	CM856581CZ	0.597	0.271	in	0.44	6	1.96	6 28309 25973 0

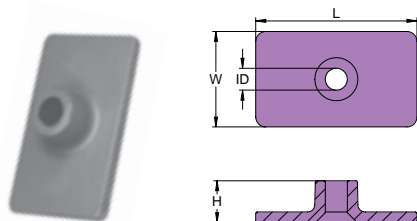

	PID	LB	KG		L	W	H	ID	UPC
Al	CM85824A3A	0.026	0.012	mm	48.5	28.75	12.6	6.6	6 28309 23517 8
Mg	CM85824A3M	0.017	0.008						6 28309 23518 5
Zn	CM85824A3Z	0.070	0.032	in	1.91	1.13	0.5	0.26	6 28309 23519 2

MERCURY 4.5-9.9 HP

MERCURY™ / MERCURISER™ ANODES

MERCURY™ / MERCUISER™ ANODES

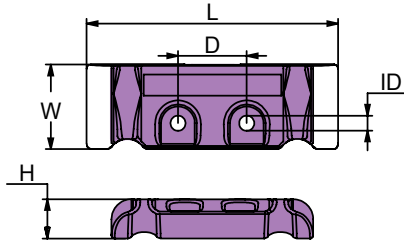

	PID	LB	KG		L	W	H	D	ID	UPC
Al	CM880653A	0.44	0.2	mm	128	43	25	35	7	6 28309 12319 2
Mg	CM880653M	0.28	0.13							6 28309 15989 4
Zn	CM880653Z	1.1	0.5	in	5	1.7	1	1.4	0.27	6 28309 12322 2

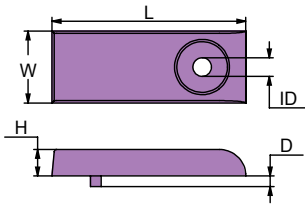

	PID	LB	KG		L	W	H	D	ID	UPC
Al	CM892227A	0.094	0.043	mm	74	27	10	4	7	6 28309 12321 5
Mg	CM892227M	0.064	0.029							6 28309 12320 8
Zn	CM892227Z	0.236	0.107	in	2.9	1.1	0.4	0.2	0.26	6 28309 15990 0

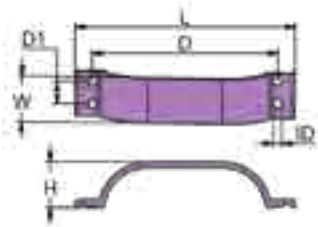

	PID	LB	KG		L	W	H	D	D1	ID	UPC
Al	CM89949A	0.92	0.42	mm	283	59	60	239	29	10.7	6 28309 12579 0
Mg	CM89949M	0.62	0.28								6 28309 19302 7
Zn	CM89949Z	2.36	1.07	in	11.14	2.3	2.35	9.4	1.15	0.42	6 28309 11369 8

150 / 200 HP

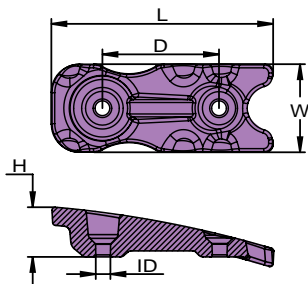

	PID	LB	KG		L	W	H	D	ID	UPC
Al	CM8M0001734A	0.264	0.120	mm	110.5	44	24.9	58	7.25	6 28309 25600 5
Mg	CM8M0001734M	0.167	0.076							6 28309 25602 9
Zn	CM8M0001734Z	0.688	0.312	in	4.35	1.73	0.98	2.28	0.28	6 28309 25598 5



Martyr®
MERCURY™ / MERCUISER™ ANODES

MERCURY™ / MERCURISER™ ANODES

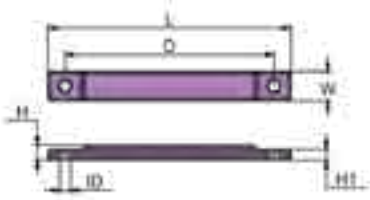

	PID	LB	KG		L	W	H	H1	D	ID	UPC
Al	CM8M0012083A	0.284	0.129	mm	195	24	12	8.7	167	8.8	6 28309 25543 5
Mg	CM8M0012083M	0.181	0.082								6 28309 25548 0
Zn	CM8M0012083Z	0.743	0.337	in	7.67	0.94	0.47	0.34	6.57	0.34	6 28309 25538 1



	PID	LB	KG		D	D1	D2	THD	L	W	H	UPC
Al	CM8M0039340A	1.953	0.886	mm	115	74	126.5	M8	161.5	150	13	6 28309 25997 6
Mg	CM8M0039340M	1.342	0.609									6 28309 26021 7
Zn	CM8M0039340Z	4.627	2.099	in	4.53	2.91	4.98	M8	6.36	5.90	0.51	6 28309 25974 7

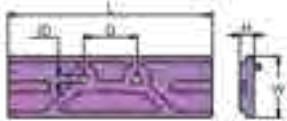
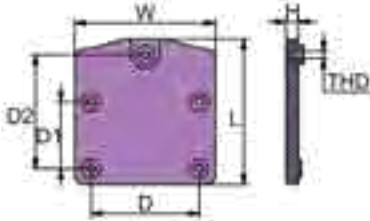

	PID	LB	KG		H	L	D	ID	W	UPC
Al	CM8M0057772A	0.476	0.216	mm	12	170	44.45	6.8	51	6 28309 25035 5
Mg	CM8M0057772M	0.302	0.137							6 28309 25036 2
Zn	CM8M0057772Z	1.239	0.562	in	0.47	6.69	1.75	0.26	2.01	6 28309 25034 8

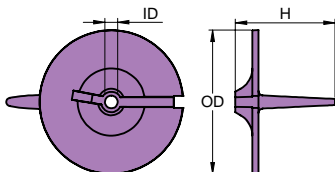

	PID	LB	KG		OD	ID	H	UPC
Al	CM94286T1A	0.247	0.112	mm	95	9	65	6 28309 23523 9
Mg	CM94286T1M	0.156	0.071					6 28309 23524 6
Zn	CM94286T1Z	0.643	0.292	in	3.7	0.33	2.6	6 28309 23525 3

OUTBOARD 25 HP

MERCURY™ / MERCURISER™ ANODES

Choose Aluminum

Al premium
SALT AND BRACKISH WATER

Anodes for salt and brackish water and Magnesium

Mg fresh
FRESH WATER ONLY
for freshwater.

MERCURY™ / MERCUISER™ ANODES

	PID	LB	KG		OD	H	THD	UPC
Al	CM984325A	0.374	0.170	mm	91	100	M8 x 1.25	6 28309 12699 5
Mg	CM984325M	0.238	0.108					6 28309 19303 4
Zn	CM984325Z	0.976	0.443	in	3.6	3.95		6 28309 11519 7

AMERICA 25 HP (FROM 1990)

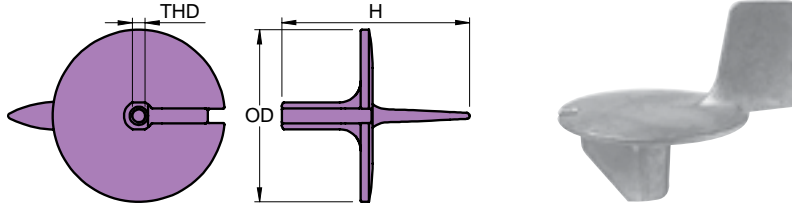

	PID	LB	KG		Shaft	L	OD	THD	Fastener	UPC
Al	CMPNCAF16	0.871	0.395	mm	28.5	73.7	50.8	3/4"-16 UNF	Fastener 5/16- 18x1 socket head w/ patch	6 28309 12373 4
Mg	CMPNCMF16	0.707	0.321							6 28309 11345 2
Zn	CMPNCZF16	1.558	0.707	in	1.12	2.9	2.0			6 28309 10832 8

FITS PROP SHAFTS FOR ALPHA I & BRAVO I

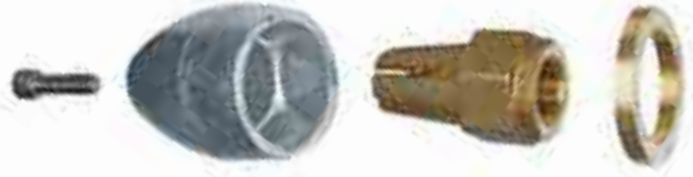
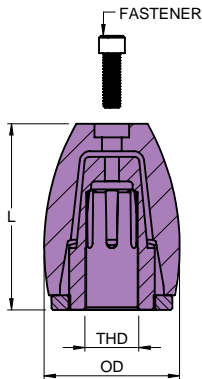

	PID	LB	KG		Shaft	L	OD	THD	Fastener	UPC
Al	CMPNEAF14	1.540	0.698	mm	34.8	86.4	63.5	1"- 14 UNS	Fastener 5/16-18x1 socket head w/ patch	6 28309 12566 0
Mg	CMPNEMF14	1.280	0.580							6 28309 12054 2
Zn	CMPNEZF14	2.620	1.188	in	1.37	3.4	2.5			6 28309 11510 4

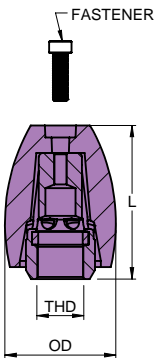

	PID	LB	KG		Shaft	L	OD	THD	Fastener	UPC
Al	CMPNDAF14UNS	1.130	0.512	mm	25.4	81.3	58.4	1"-14 UNS	Fastener 5/16- 18x1 socket head w/ patch	6 28309 12259 1
Mg	CMPNDMF14UNS	0.900	0.408							6 28309 12264 5
Zn	CMPNDZF14UNS	2.140	0.970	in	1	3.2	2.3			6 28309 12231 7

FITS PROP SHAFTS FOR BRAVO III 2003 AND OLDER



Martyr®
MERCURY™ / MERCUISER™ ANODES

NEW MERCURY™ ANODE KITS



	PID	LB	KG	Contains	Fits	UPC
Al	CM8M0039340KITA	4.241	1.924	CM8M0039340 x 2	ZEUS POD TRIMTAB	6 28309 26903 6
Mg	CM8M0039340KITM	3.020	1.370			6 28309 26904 3
Zn	CM8M0039340KITZ	9.590	4.350			6 28309 26902 9



	PID	LB	KG	Contains	Fits	UPC
Al	CM8M0107548KITA	1.54	0.70	CM8M0057772 x 1 CM826134 x 2 CM762145 x 1	MERCURY 8M0107548	6 28309 25580 0
Mg	CM8M0107548KITM	1.14	0.52			6 28309 25584 8
Zn	CM8M0107548KITZ	3.42	1.55			6 28309 25576 3



	PID	LB	KG	Contains	Fits	UPC
Al	CM8M0116590KITA	1.85	0.84	CM826134 x 2 CM762145 x 1 CM892227 x 2 CM8M0012083 x 1 CM8M0001734 x 1	MERCURY VERADO MMP	6 28309 25601 2
Mg	CM8M0116590KITM	1.45	0.66			6 28309 25603 6
Zn	CM8M0116590KITZ	3.66	1.66			6 28309 25599 2



	PID	LB	KG	Contains	Fits	UPC
Al	CMM3060KITA	1.71	0.776	CM17264C1 x 1 CM826134 x 2 CM818298 x 1	MERCURY F30-F40-F60	6 28309 26008 8
Mg	CMM3060KITM	1.19	0.548			6 28309 26030 9
Zn	CMM3060KITZ	4.03	1.832			6 28309 25984 6



	PID	LB	KG	Contains	Fits	UPC
Al	CMM75115KITA	1.83	0.83	CM31640 x 1 CM826134 x 2 CM818298 x 1	Fits MERCURY 75-80-90-100- 115	6 28309 26009 5
Mg	CMM75115KITM	1.32	0.60			6 28309 26031 6
Zn	CMM75115KITZ	4.19	1.90			6 28309 25985 3

MERCURY™ / MERCURUISER™ ANODES

MERCURY™ ANODE KITS

PLEASE NOTE: KITS IN PICTURES SHOWN IN ALUMINUM ALLOY.
SEE THE CATALOG LISTING FOR ALL ALLOYS AVAILABLE.



	PID	LB	KG	Contains	Fits	UPC
Al	CMALPHAKITA	2.58	1.17	CM762145 X 1 CM806105 X 1 CM821629 X 1 CM821631 X 1 CM806189 X 2	Alpha I Generation II Engine 1991 - present	6 28309 11552 4
Mg	CMALPHAKITM	1.83	0.83			6 28309 12263 8
Zn	CMALPHAKITZ	5.61	2.55			6 28309 12611 7



	PID	LB	KG	Contains	Fits	UPC
Al	CMBRAVO1KITA	2.568	1.165	CM762145 X 1 CM806188 X 1 CM821630C2 X 1 CM806190 X 2	Bravo I Engine 1988 - present	6 28309 11553 1
Mg	CMBRAVO1KITM	1.838	0.834			6 28309 12261 4
Zn	CMBRAVO1KITZ	5.820	2.640			6 28309 12612 4



	PID	LB	KG	Contains	Fits	UPC
Al	CMBRAVO23KITA	2.315	1.050	CM762145 X 1 CM821630C2 X 1 CM806190 X 2	Bravo II 1989 - present & Bravo III 1989 - 2003	6 28309 11554 8
Mg	CMBRAVO23KITM	1.534	0.696			6 28309 12262 1
Zn	CMBRAVO23KITZ	5.247	2.380			6 28309 12613 1



	PID	LB	KG	Contains	Fits	UPC
Al	CMBRAVO3KITA	2.875	1.304	CM762144 X 1 CM762145 X 1 CM865182C X 1 CM821630C2 X 1 CM806190 X 2	Bravo III Engine 2004 - present	6 28309 12473 1
Mg	CMBRAVO3KITM	2.268	1.029			6 28309 12578 3
Zn	CMBRAVO3KITZ	6.702	3.040			6 28309 12614 8



	PID	LB	KG	Fits	UPC
Al	CM31640KITA	0.705	0.320	Alpha I Generation I Engine	6 28309 12291 1
Mg	CM31640KITM	0.397	0.180		6 28309 12307 9



	PID	LB	KG	Fits	UPC
Al	CM55989KITA	0.341	0.155	Alpha I Generation I Engine	6 28309 12301 7
Mg	CM55989KITM	0.286	0.130		6 28309 12281 2

MERCURY™ ANODE KITS

PLEASE NOTE: KITS IN PICTURES SHOWN IN ALUMINUM ALLOY.
SEE THE CATALOG LISTING FOR ALL ALLOYS AVAILABLE.



	PID	LB	KG	Contains	Fits	UPC
Al	CMM3060KITA	1.71	0.776	CM17264C1 X 1 CM826134 X 2 CM818298 X 1	F30-F40-F60 HP	6 28309 26008 8
Mg	CMM3060KITM	1.21	0.548			6 28309 26030 9
Zn	CMM3060KITZ	4.04	1.832			6 28309 25984 6



	PID	LB	KG	Contains	Fits	UPC
Al	CMM75115KITA	1.83	0.832	CM818298 X 1 CM31640 X 1 CM826134 X 2	75-80-90-100- 115 HP	6 28309 26009 5
Mg	CMM75115KITM	1.31	0.594			6 28309 26031 6
Zn	CMM75115KITZ	4.19	1.9			6 28309 25985 3



	PID	LB	KG	Contains	Fits	UPC
Al	CMALPHAGEN1KITA	1.649	0.748	CM31640 X 1 CM55989 X 2 CM821631 X 1	Alpha I Generation I Engine 1983 - 1990	6 28309 12807 4
Mg	CMALPHAGEN1KITM	1.179	0.535			6 28309 12808 1
Zn	CMALPHAGEN1KITZ	3.931	1.783			6 28309 12809 8



	PID	LB	KG	Contains	Fits	UPC
Al	CMVERADO4KITA	1.72	0.78	CM818298 X 1 CM826134 X 2 CM762145 X 1	Verado 4 / OPTIMAX Engine	6 28309 12272 0
Mg	CMVERADO4KITM	1.23	0.56			6 28309 16576 5



	PID	LB	KG	Contains	Fits	UPC
Al	CMVERADO6KITA	1.96	0.89	CM880653 X 1 CM892227 X 4 CM826134 X 2 CM762145 X 1	Verado 6 Engine	6 28309 12273 7
Mg	CMVERADO6KITM	1.41	0.64			6 28309 16577 2

MERCURY™ / MERCURUISER™ ANODES

Choose
Aluminum

Al premium
SALT AND BRACKISH WATER

Anodes for
salt and brackish
water and
Magnesium

Mg fresh
FRESH WATER ONLY

for freshwater.



MERCURY™ ANODE KITS

PLEASE NOTE: KITS IN PICTURES SHOWN IN ALUMINUM ALLOY. SEE THE CATALOG LISTING FOR ALL ALLOYS.

PID		LB	KG	Fits	UPC
Al	CM818298KITA	0.8	0.36	Verado 4 / OPTIMAX Engine	6 28309 12303 1
Mg	CM818298KITM	0.58	0.26		6 28309 12283 6



PID		LB	KG	Fits	UPC
Al	CM821629KITA	0.928	0.421	Alpha I Generation II Engine	6 28309 12299 7
Mg	CM821629KITM	0.701	0.318		6 28309 12279 9



PID		LB	KG	Fits	UPC
Al	CM821630KITA	1.08	0.49	Bravo I 1988 - present, Bravo II 1989 - present & Bravo III 1989 - 2003	6 28309 12300 0
Mg	CM821630KITM	0.79	0.36		6 28309 12280 5



PID		LB	KG	Fits	UPC
Al	CM821631KITA	1	0.45	Alpha I Generation I Engine, Alpha I Generation II Engine	6 28309 12292 8
Mg	CM821631KITM	0.71	0.32		6 28309 12308 6



PID		LB	KG	Fits	UPC
Al	CM826134KITA	0.62	0.28	Mercury Mariner 30-0125HP (1987-Present), V-6 and OPTIMAX Outboard and Verado 4	6 28309 12302 4
Mg	CM826134KITM	0.46	0.21		6 28309 12282 9



PID		LB	KG	Fits	UPC
Al	CM865182KITA	0.635	0.288	Bravo III Engine 2004 - present	6 28309 12345 1
Mg	CM865182KITM	0.496	0.225		6 28309 12346 8

Martyr®
MERCURY™ / MERCURISER™ ANODES

MERCURY™ ANODE KITS

**PLEASE NOTE: KITS IN PICTURES SHOWN IN ALUMINUM ALLOY.
SEE THE CATALOG LISTING FOR ALL ALLOYS AVAILABLE.**



	PID	LB	KG	Fits	UPC
Al	CM762144KITA	0.586	0.266	Bravo III Engine 2004 - present	6 28309 12293 5
Mg	CM762144KITM	0.425	0.193		6 28309 12309 3



	PID	LB	KG	Fits	UPC
Al	CM762145KITA	0.586	0.266	Alpha I Generation II Engine, Bravo I, Bravo II, Bravo III, Verado 4, 6	6 28309 12294 2
Mg	CM762145KITM	0.425	0.193		6 28309 11544 9



	PID	LB	KG	Fits	UPC
Al	CM806105KITA	0.38	0.17	Alpha I Generation II Engine	6 28309 12297 3
Mg	CM806105KITM	0.31	0.14		6 28309 12277 5



	PID	LB	KG	Fits	UPC
Al	CM806188KITA	0.304	0.138	Bravo I 1988 - present	6 28309 12298 0
Mg	CM806188KITM	0.260	0.118		6 28309 12278 2



	PID	LB	KG	Fits	UPC
Al	CM806189KITA	0.36	0.16	Alpha I Generation II Engine	6 28309 12295 9
Mg	CM806189KITM	0.3	0.14		6 28309 12305 5



	PID	LB	KG	Fits	UPC
Al	CM806190KITA	0.8	0.36	Bravo I 1988 - present, Bravo II 1989 - present & Bravo III 1989 - 2003	6 28309 12296 6
Mg	CM806190KITM	0.58	0.26		6 28309 12306 2

MERCURY™ / MERCRCRUISER™ ANODES

NISSAN™ TOHATSU™ ANODES

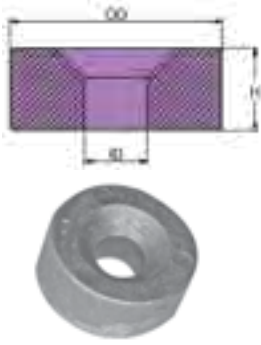

	PID	LB	KG		OD	ID	H	UPC
Al	CM338602182A	0.0149	0.0067	mm	22	6.5	8.5	6 28309 22961 0
Mg	CM338602182M	0.0095	0.0043					6 28309 23165 1
Zn	CM338602182Z	0.0386	0.0175	in	0.86	0.25	0.33	6 28309 23140 8

	PID	LB	KG		L	W	W1	H	D	D1	ID	UPC
Al	CM3C7602181A0A	0.407	0.184	mm	196	40	6	14	178	4	8	6 28309 24166 7
Mg	CM3C7602181A0M	0.288	0.130									6 28309 24272 5
Zn	CM3C7602181A0Z	1.069	0.485	in	7.7	1.6	0.25	0.5	7	0.16	0.31	6 28309 24100 1

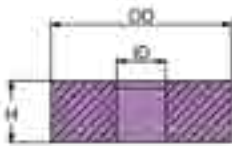
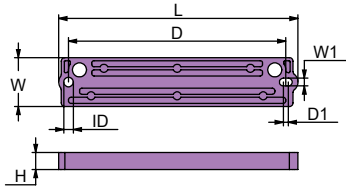

	PID	LB	KG		OD	ID	H	UPC
Al	CM5338602182A0A	0.017	0.008	mm	24	7	8	6 28309 17567 2
Mg	CM5338602182A0M	0.011	0.005					6 28309 23924 4
Zn	CM5338602182A0Z	0.044	0.020	in	0.9	0.3	0.3	6 28309 17445 3

ALSO APPLY TO HIDEA

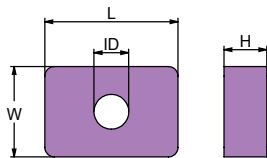

	PID	LB	KG		L	W	H	ID	UPC
Al	CM3H660218000A	0.022	0.0100	mm	28	19	9	6	6 28309 17442 2
Mg	CM3H660218000M	0.014	0.0063						6 28309 18317 2
Zn	CM3H660218000Z	0.057	0.0260	in	1.1	0.7	0.4	0.25	6 28309 17562 7

ALSO APPLY TO PARSUN & SHENFENG

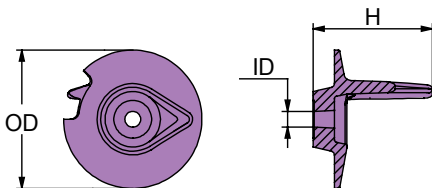

	PID	LB	KG		OD	ID	H	UPC
Al	CM3V1602170A	0.077	0.035	mm	55	6	48	6 28309 17563 4
Mg	CM3V1602170M	0.048	0.022					6 28309 19290 7
Zn	CM3V1602170Z	0.203	0.092	in	2.2	0.25	1.9	6 28309 17443 9

140 HP

ALSO APPLY TO HIDEA



Martyr®
NISSAN™ TOHATSU™ ANODES

NISSAN™ TOHATSU™ ANODES

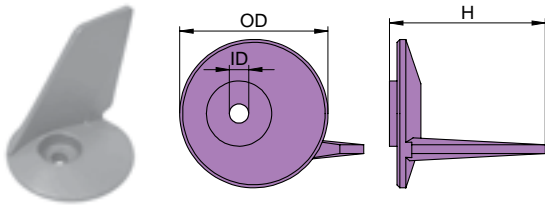

	PID	LB	KG		OD	ID	H	UPC
Al	CM348602170A	0.106	0.048	mm	50	6	50	6 28309 23153 8
Mg	CM348602170M	0.066	0.030					6 28309 23167 5
Zn	CM348602170Z	0.275	0.125	in	2	0.25	2	6 28309 23141 5

FIN 25-40 HP

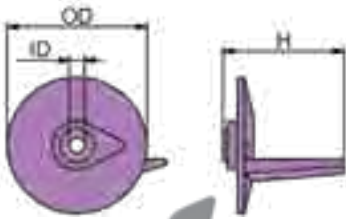

	PID	LB	KG		OD	ID	H	UPC
Al	CM3C86021700A	0.117	0.053	mm	59	6	51	6 28309 21150 9
Mg	CM3C86021700M	0.075	0.034					6 28309 21171 4
Zn	CM3C86021700Z	0.302	0.137	in	2.3	0.25	2	6 28309 21126 4

MEGA 25-50 HP

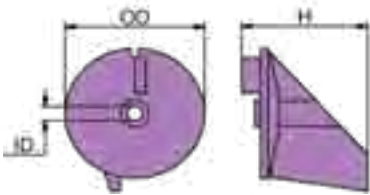

	PID	LB	KG		OD	ID	H	UPC
Al	CM3B76021700A	0.31	0.14	mm	77	8	70	6 28309 21149 3
Mg	CM3B76021700M	0.20	0.09					6 28309 21170 7
Zn	CM3B76021700Z	0.76	0.35	in	3	0.3	2.76	6 28309 21125 7

60-70-90-120-140 HP

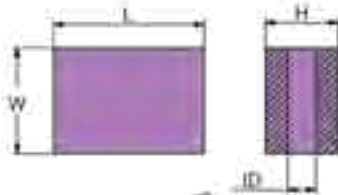

	PID	LB	KG		L	W	H	ID	UPC
Al	CM3B7602181A	0.035	0.016	mm	28	20	13	5.95	6 28309 23154 5
Mg	CM3B7602181M	0.022	0.010						6 28309 23168 2
Zn	CM3B7602181Z	0.093	0.042	in	1.1	0.8	0.5	0.23	6 28309 23142 2

MEGA ENGINES

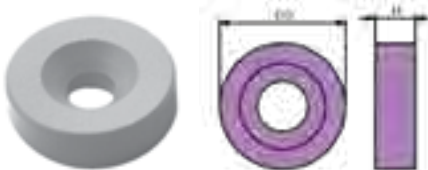

	PID	LB	KG		OD	H	UPC
Zn	CM369602181Z	0.04	0.02	mm	25	8	6 28309 24099 8
				in	1	0.3	

2.5-8 HP

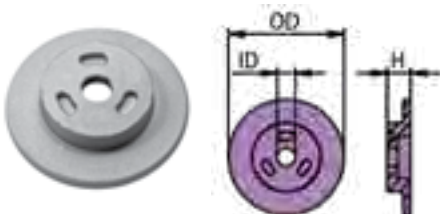

	PID	LB	KG		OD	ID	H	UPC
Al	CM3M2602181A	0.039	0.018	mm	45	7	9	6 28309 23155 2
Mg	CM3M2602181M	0.026	0.012					6 28309 23169 9
Zn	CM3M2602181Z	0.106	0.048	in	1.8	0.26	0.4	6 28309 23143 9

40-140 HP

Choose
Aluminum

Al premium
SALT AND BRACKISH WATER

Anodes for
salt and brackish
water and
Magnesium

Mg fresh
FRESH WATER ONLY
for freshwater.

PAINIER™ ANODES

	PID	LB	KG		OD	ID	H	UPC
Al	CM6634525100A	0.03	0.02	mm	24	7	14	6 28309 19531 1
Mg	CM6634525100M	0.02	0.01					6 28309 19532 8
Zn	CM6634525100Z	0.09	0.04	in	0.9	0.3	0.6	6 28309 19533 5

YAMAHA 40 - 50 - 70 - 90 - HP UP TO 1987

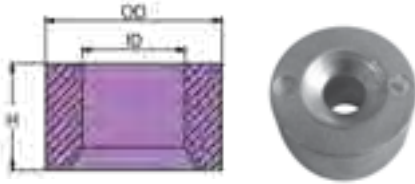

	PID	LB	KG		L	W	H	D	ID	UPC
Al	CM63D4525101A	0.483	0.219	mm	86	62	32	47	7	6 28309 19528 1
Mg	CM63D4525101M	2.205	0.139							6 28309 19529 8
Zn	CM63D4525101Z	1.259	0.571	in	3.4	2.4	1.3	1.9	0.3	6 28309 19530 4

YAMAHA 40 - 50 HP

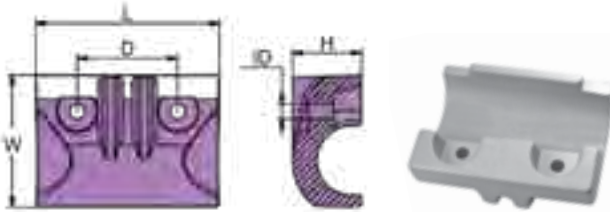

	PID	LB	KG		L	OD	OD1	D	UPC
Al	CM6H31132501A	0.017	0.008	mm	68	16	8	12.6	6 28309 19534 2
Mg	CM6H31132501M	0.011	0.005						6 28309 19535 9
Zn	CM6H31132501Z	0.044	0.020	in	2.7	0.6	0.3	0.5	6 28309 19536 6

YAMAHA 200 - 225 - 250 HP UP TO 2003

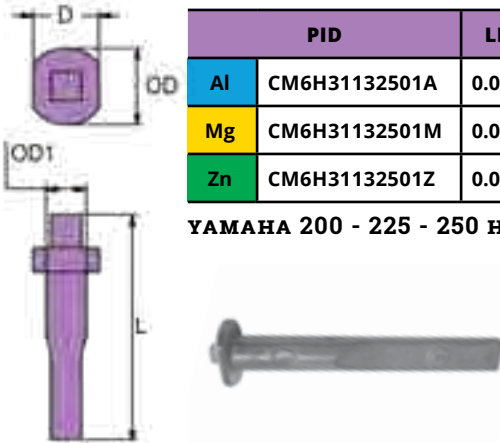

PARSUN™ ANODES

	PID	LB	KG		OD	ID	H	UPC
Al	CM6G81132500A	0.0088	0.004	mm	13.95	5.2	15	6 28309 23163 7
Mg	CM6G81132500M	0.0055	0.0025					6 28309 23177 4
Zn	CM6G81132500Z	0.0229	0.0104	in	0.55	0.2	0.6	6 28309 23151 4

ALSO APPLY TO YAMAHA 4 - 6 - 8 - 9 - 9,9 - 15 - 20 - 25 - 30 - 40 - 50 - 60 - 70 HP,
ALLPASS, HIDEA, TIGER & PAINIER

Martyr
PAINIER™ ANODES

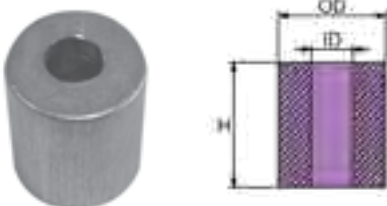

PARSUN™ ANODES

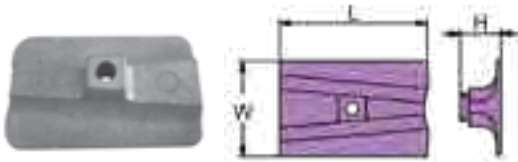

	PID	LB	KG		L	W	H	UPC
Al	CM8018A	0.119	0.054	mm	80	50	22	6 28309 19540 3
Mg	CM8018M	0.075	0.034					6 28309 19541 0
Zn	CM8018Z	0.311	0.141	in	3.1	2	0.9	6 28309 19542 7

ALSO APPLY TO YAMAHA



	PID	LB	KG		L	OD	THD	UPC
Al	CM66M1132500A	0.011	0.005	mm	32	11	M5 x 0.8	6 28309 23156 9
Mg	CM66M1132500M	0.006	0.003					6 28309 23170 5
Zn	CM66M1132500Z	0.028	0.013	in	1.3	0.4		6 28309 23144 6

ALSO APPLY TO YAMAHA 9,9 - 15 - 200 - 225 -250 - 300 HP, ALLPASS, HIDEA & TIGER

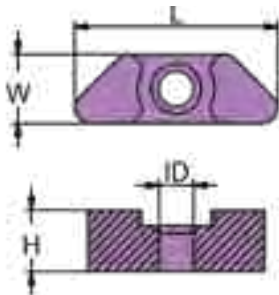

	PID	LB	KG		L	W	H	ID	UPC
Al	CM6E51132500A	0.009	0.0040	mm	27	9	10	5	6 28309 23162 0
Mg	CM6E51132500M	0.005	0.0025						6 28309 23176 7
Zn	CM6E51132500Z	0.023	0.0104	in	1.1	0.4	0.2		6 28309 23150 7

ALSO APPLY TO YAMAHA 6 - 9,9 - 15 -20 - 75 -90 - 115 - 130 - 150 - 175 - 200 - 225 - 250 - 300 - 350 HP, ALLPASS, HIDEA, TIGER & PAINIER

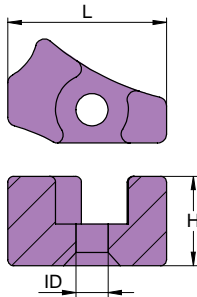

	PID	LB	KG		L	H	ID	UPC
Al	CM6821132500A	0.017	0.008	mm	27	15	5.4	6 28309 23159 0
Mg	CM6821132500M	0.011	0.005					6 28309 23173 6
Zn	CM6821132500Z	0.04	0.02	in	1.1	0.6		0.21

YAMAHA 9,9 - 15 HP

ALSO APPLY TO ALLPASS, HIDEA, TIGER & PAINIER

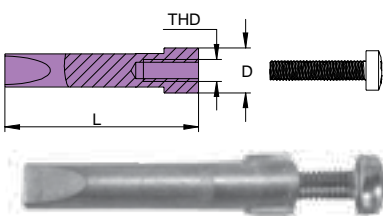

	PID	LB	KG		L	D	THD	UPC
Al	CM62Y1132500A	0.024	0.011	mm	49	11.4	M5 x 0.8	6 28309 21133 2
Mg	CM62Y1132500M	0.019	0.009					6 28309 21157 8
Zn	CM62Y1132500Z	0.046	0.021	in	1.9	0.45		6 28309 21178 3

ALSO APPLY TO YAMAHA 25 - 30 - 40 -50 - 60 -70 - 150 - 175 - 200 - 225 -250 HP

PARSUN™ ANODES

PARSUN™ ANODES

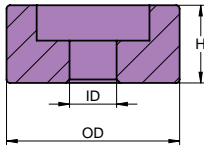

	PID	LB	KG		OD	ID	H	UPC
Al	CM6764525100A	0.022	0.0100	mm	24.5	6.7	11	6 28309 23158 3
Mg	CM6764525100M	0.014	0.0063					6 28309 23172 9
Zn	CM6764525100Z	0.05	0.026	in	1	0.26	0.43	6 28309 23146 0

ALSO APPLY TO YAMAHA, ALLPASS, HIDEA, TIGER & PAINIER

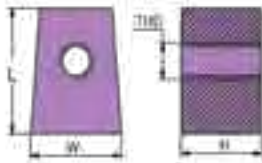

	PID	LB	KG		L	W	H	THD	UPC
Al	CM67C4525100A	0.103	0.047	mm	34.5	26.5	23.5	M8 x1.25	6 28309 20957 5
Mg	CM67C4525100M	0.066	0.030						6 28309 20978 0
Zn	CM67C4525100Z	0.260	0.118	in	1.36	1.04	0.93		6 28309 20936 0

ALSO APPLY TO YAMAHA, ALLPASS, HIDEA, TIGER & PAINIER

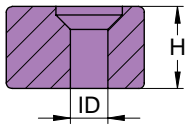
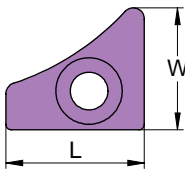

	PID	LB	KG		L	W	H	ID	UPC
Al	CM6761132500A	0.02	0.011	mm	25	22	15	7	6 28309 23157 6
Mg	CM6761132500M	0.01	0.007						6 28309 23171 2
Zn	CM6761132500Z	0.06	0.028	in	1	0.9	0.6	0.3	6 28309 23145 3

YAMAHA 40 HP; ALSO APPLY TO HIDEA, TIGER & PAINIER

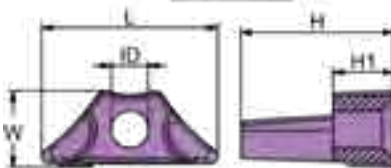

	PID	LB	KG		L	W	H	H1	ID	UPC
Al	CM6881132500A	0.008	0.0036	mm	23	10	20	8	5	6 28309 23160 6
Mg	CM6881132500M	0.005	0.0023							6 28309 23174 3
Zn	CM6881132500Z	0.020	0.0092	in	0.9	0.4	0.8	0.3	0.2	6 28309 23148 4

ALSO APPLY TO YAMAHA 40 - 50 - 75 - 80 - 85 - 90 HP

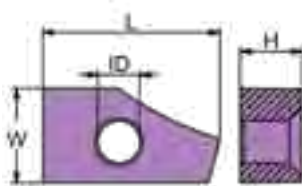

	PID	LB	KG		L	W	H	ID	UPC
Al	CM6891132500A	0.015	0.0069	mm	28	15	10	6.6	6 28309 23161 3
Mg	CM6891132500M	0.009	0.0044						6 28309 23175 0
Zn	CM6891132500Z	0.039	0.018	in	1.1	0.59	0.39	0.26	6 28309 23148 4

ALSO APPLY TO YAMAHA 25 - 30 HP UP TO 1997, ALLPASS, HIDEA & PAINIER

Martyr®
PARSUN™ ANODES

RENAULT™ ANODES

NUT FOR SHAFT

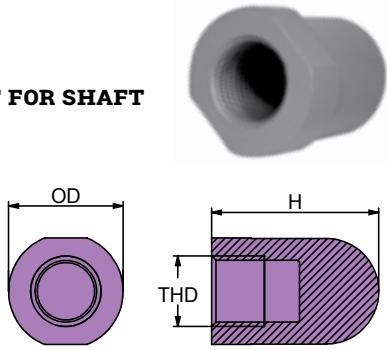

PID		LB	KG		OD	H	THD	UPC	
Al	CMRE16A	0.075	0.034	mm	26	38	M16 x 2	6 28309 20970 4	
Mg	CMRE16M	0.048	0.022					6 28309 20991 9	
Zn	CMRE16Z	0.174	0.079	in	1	1.5		6 28309 20949 0	
Al	CMRE20A	0.136	0.062	mm	35	50	M20 x 2.5	6 28309 20971 1	
Mg	CMRE20M	0.086	0.039					6 28309 20992 6	
Zn	CMRE20Z	0.308	0.140	in	1.4	2		6 28309 20950 6	

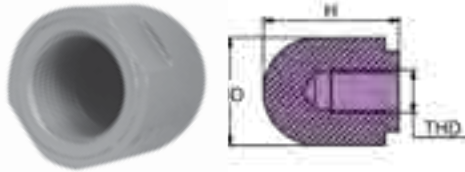

PID		LB	KG		OD	H	THD	UPC	
Al	CMRE28A	0.183	0.083	mm	40	49	M28 x2.5	6 28309 20972 8	
Mg	CMRE28M	0.117	0.053					6 28309 20993 3	
Zn	CMRE28Z	0.476	0.216	in	1.6	1.9		6 28309 20951 3	

NUT FOR SHAFT

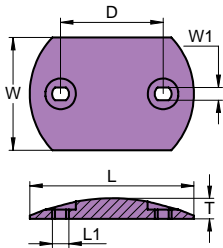

PID		LB	KG		L	L1	W	W1	D	T	UPC	
Al	CMRE50A	0.141	0.064	mm	80	8.2	55	6.2	48	10	6 28309 23783 7	
Mg	CMRE50M	0.090	0.041								6 28309 23784 4	
Zn	CMRE50Z	0.368	0.167	in	3.15	0.32	2.17	0.24	1.89	0.39	6 28309 23785 1	

W/ BRASS PLUG

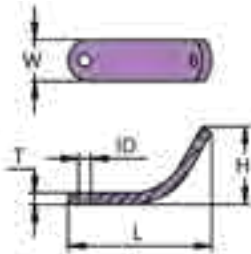

PID		LB	KG		L	W	H	ID	T	UPC	
Al	CM9005660A	0.020	0.0091	mm	52	15	28	4.4	4	6 28309 23218 4	
Mg	CM9005660M	0.012	0.0057							6 28309 23232 0	
Zn	CM9005660Z	0.052	0.0237	in	2	0.6	1.1	0.173	0.16	6 28309 23201 6	

FB SERIES CURVE

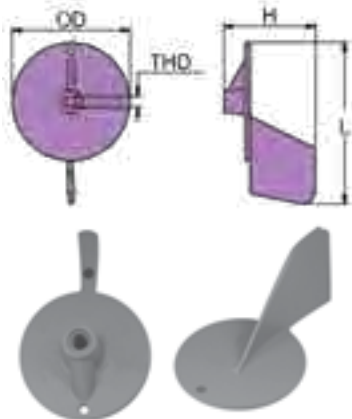

PID		LB	KG		L	H	OD	THD	UPC	
Al	CM2500050A	0.174	0.079	mm	88	70	59	M8 x 1.25	6 28309 23207 8	
Mg	CM2500050M	0.110	0.050						6 28309 23221 4	
Zn	CM2500050Z	0.452	0.205	in	3.46	2.76	2.32		6 28309 23190 3	

BEST 800-s1000

Choose
Aluminum

Al premium
SALT AND BRACKISH WATER

Anodes for
salt and brackish
water and
Magnesium

Mg fresh
FRESH WATER ONLY
for freshwater.

SELVA™ ANODES

	PID	LB	KG		L	OD	ID	H	UPC
Zn	CM2500065Z	0.22	0.1	mm	47	40	7	48	6 28309 23191 0
				in	1.85	1.6	0.26	1.9	

25-40 HP

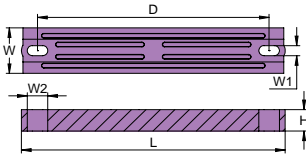

	PID	LB	KG		L	W	H	D	W1	W2	UPC
Al	CM2504015A	0.483	0.219	mm	205	36	17	180	8	16	6 28309 23209 2
Mg	CM2504015M	0.306	0.139								6 28309 23223 8
Zn	CM2504015Z	1.261	0.572	in	8.07	1.42	0.67	7.09	0.31	0.63	6 28309 23192 7

S600 SERIES



Martyr
SELVA™ ANODES

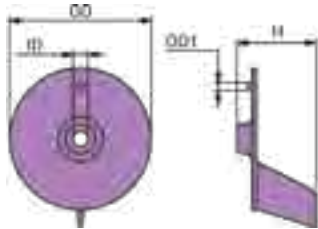

	PID	LB	KG		OD	OD1	ID	H	UPC
Al	CM82795MA	0.185	0.084	mm	95	4.9	9	53	6 28309 20959 9
Mg	CM82795MM	0.128	0.058						6 28309 20980 3
Zn	CM82795MZ	0.483	0.219	in	3.7	0.19	0.33	2.1	6 28309 20938 4

YAMAHA 25-30 HP, MANTA / BARRACUDA

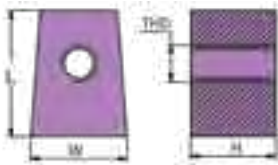

	PID	LB	KG		L	W	H	THD	UPC
Al	CM67C4525100A	0.103	0.047	mm	34.5	26.5	23.5	M8 x1.25	6 28309 20957 5
Mg	CM67C4525100M	0.066	0.030						6 28309 20978 0
Zn	CM67C4525100Z	0.260	0.118	in	1.36	1.04	0.93		6 28309 20936 0

YAMAHA T25 - F30 - F40 - F50 - F60 HP



SUZUKI™ ANODES

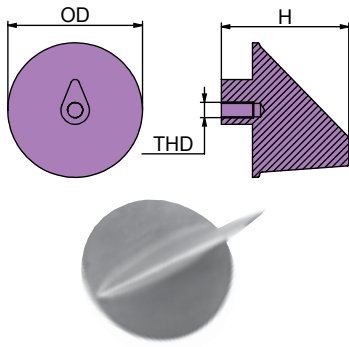

	PID	LB	KG		OD	H	THD	UPC
Al	CM5512587D00A	0.286	0.130	mm	89	84	M10	6 28309 24171 1
Mg	CM5512587D00M	0.183	0.083					6 28309 24279 4
Zn	CM5512587D00Z	0.749	0.340	in	3.5	3.3	1.25	6 28309 10057 5

SUZUKI 50 - 70 HP DT150 - DT175 - DT200 - DT225 4 T

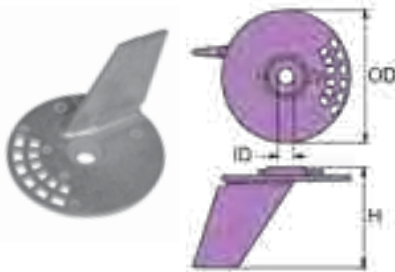

	PID	LB	KG		OD	ID	H	UPC
Al	CM551259630A	0.100	0.045	mm	70	8	53	6 28309 19258 7
Mg	CM551259630M	0.064	0.029					6 28309 19295 2
Zn	CM551259630Z	0.260	0.118	in	2.7	0.3	2.1	6 28309 10058 2

DF60 - DF70

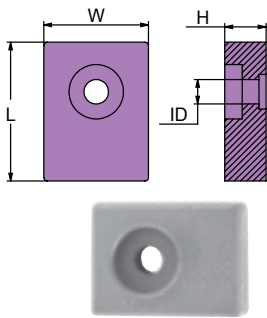

	PID	LB	KG		L	W	H	ID	UPC
Al	CM5532095310A	0.070	0.032	mm	40	30	12	7	6 28309 19259 4
Mg	CM5532095310M	0.046	0.021						6 28309 19296 9
Zn	CM5532095310Z	0.176	0.080	in	1.6	1.2	0.5	0.26	6 28309 10059 9

	PID	LB	KG		L	W	W1	H	D	D1	ID	UPC
Al	CM5532194900A	0.407	0.184	mm	196	40	6	14	178	4	8	6 28309 24173 5
Mg	CM5532194900M	0.288	0.130									6 28309 24282 4
Zn	CM5532194900Z	1.069	0.485	in	7.7	1.6	0.25	0.5	7	0.16	0.31	6 28309 24106 3

70 - 90 - 115 - 140 - 150 CV. ALSO FITS BRP™ & MERCURY™

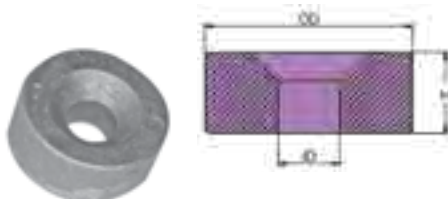
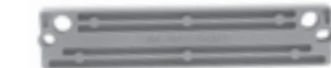
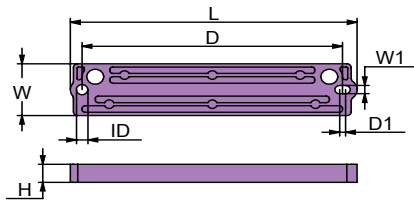

	PID	LB	KG		OD	ID	H	UPC
Al	CM1113094600A	0.0149	0.0067	mm	22	6.5	8.5	6 28309 20952 0
Mg	CM1113094600M	0.0095	0.0043					6 28309 20973 5
Zn	CM1113094600Z	0.0386	0.0175	in	0.86	0.25	0.33	6 28309 20931 5

YAMAHA 40 HP UP TO 1997
SUZUKI FB

SUZUKI™ ANODES

SUZUKI™ ANODES

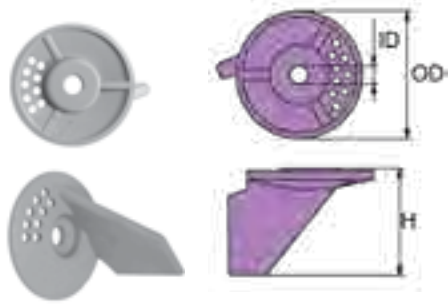

	PID	LB	KG		OD	ID	H	UPC
Al	CM5512595301A	0.114	0.052	mm	60	8.4	50	6 28309 20955 1
Mg	CM5512595301M	0.072	0.033					6 28309 20976 6
Zn	CM5512595301Z	0.297	0.135	in	2.4	0.33	2	6 28309 20934 6

SUZUKI 55-65 HP

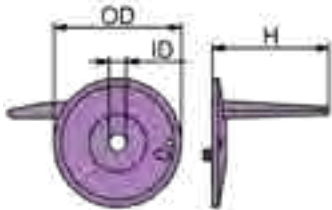

	PID	LB	KG		OD	H	ID	UPC
Al	CM5512595500A	0.149	0.068	mm	62	57	9	6 28309 21153 0
Mg	CM5512595500M	0.094	0.043					6 28309 21174 5
Zn	CM5512595500Z	0.352	0.160	in	2.4	2.24	0.33	6 28309 21129 5

75-85 HP

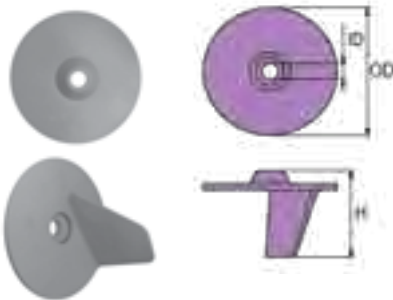

	PID	LB	KG		OD	ID	H	UPC
Al	CM5512594502A	0.262	0.119	mm	99	11	67	6 28309 23359 4
Mg	CM5512594502M	0.167	0.076					6 28309 23360 0
Zn	CM5512594502Z	0.688	0.312	in	3.9	0.44	2.6	6 28309 23361 7

SUZUKI 115 HP

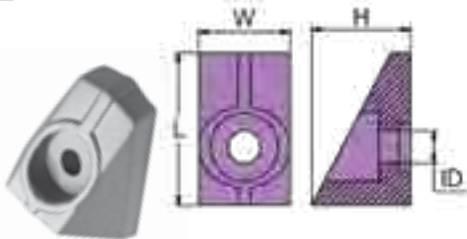

	PID	LB	KG		L	W	H	ID	UPC
Al	CM5532098600A	0.075	0.034	mm	38	39	23	6.4	6 28309 23365 5
Mg	CM5532098600M	0.048	0.022						6 28309 23366 2
Zn	CM5532098600Z	0.196	0.089	in	0.8	1.54	0.9	0.25	6 28309 23367 9

**OUTBOARD
SUZUKI FB**

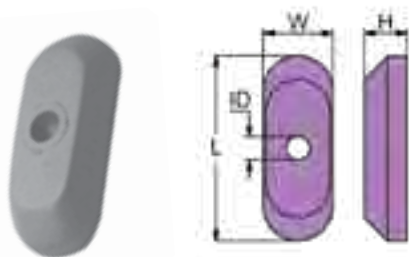

	PID	LB	KG		L	W	H	ID	UPC
Al	CM5532098400A	0.046	0.021	mm	48	18	11	6	6 28309 21154 7
Mg	CM5532098400M	0.028	0.013						6 28309 21175 2
Zn	CM5532098400Z	0.112	0.051	in	1.9	0.7	0.4	0.2	6 28309 21130 1

SUZUKI 2 HP

Martyr
SUZUKI™ ANODES

SUZUKI™ ANODES

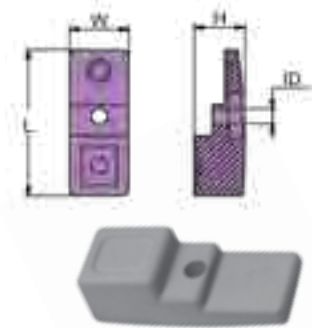

	PID	LB	KG		L	W	H	ID	UPC
Al	CM5532190J01A	0.079	0.036	mm	55	22	19	6	6 28309 21155 4
Mg	CM5532190J01M	0.050	0.023						6 28309 21176 9
Zn	CM5532190J01Z	0.200	0.091	in	2.2	0.9	0.7	0.2	6 28309 21131 8

DF 90 - 115 -140

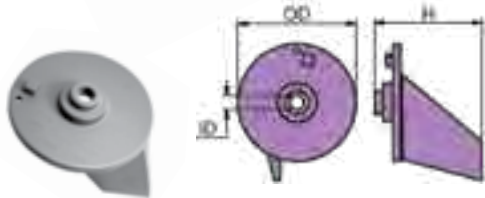

	PID	LB	KG		OD	H	ID	UPC
Al	CM5512587E01A	0.191	0.087	mm	73	66	9	6 28309 24172 8
Mg	CM5512587E01M	0.123	0.056					6 28309 24280 0
Zn	CM5512587E01Z	0.456	0.207	in	2.9	2.6	0.33	6 28309 24105 6

70-90-115-140 HP

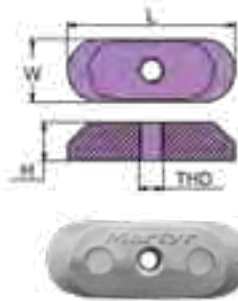

	PID	LB	KG		L	W	H	THD	UPC
Al	CM4181198500A	0.046	0.021	mm	48	18	11	M6 x 1	6 28309 23213 9
Mg	CM4181198500M	0.028	0.013						6 28309 23227 6
Zn	CM4181198500Z	0.112	0.051	in	1.9	0.7	0.4		6 28309 23196 5

2.2-4 HP

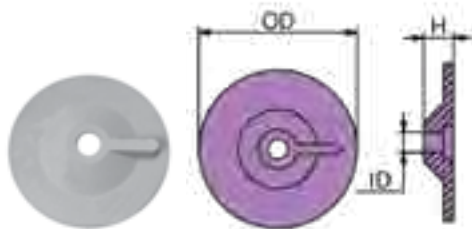

	PID	LB	KG		OD	H	ID	UPC
Al	CM5532193900A	0.046	0.021	mm	48	9	7	6 28309 20956 8
Mg	CM5532193900M	0.028	0.013					6 28309 20935 3
Zn	CM5532193900Z	0.121	0.055	in	1.9	0.4	0.26	6 28309 20977 3

9.9-15 HP 4T

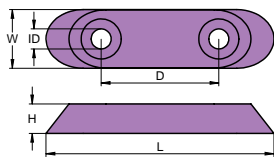

	PID	LB	KG		L	W	H	D	ID	UPC
Al	CM5530095500A	0.05	0.023	mm	78	20	10	40	7	6 28309 23927 5
Mg	CM5530095500M	0.04	0.019							6 28309 23928 2
Zn	CM5530095500Z	0.17	0.08	in	3.1	0.79	0.4	1.6	0.26	6 28309 23926 8

2-8 HP

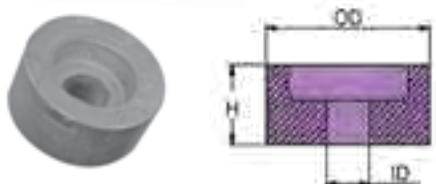

	PID	LB	KG		OD	H	ID	UPC
Al	CM5532187J00A	0.015	0.007	mm	21	10	6	6 28309 12963 7
Mg	CM5532187J00M	0.009	0.004					6 28309 24281 7
Zn	CM5532187J00Z	0.039	0.018	in	0.83	0.39	0.24	6 28309 19252 5

ENGINES 3,5 - 5 - 6 HP 4T

SUZUKI™ ANODES

Choose
Aluminum

Al premium
SALT AND BRACKISH WATER

Anodes for
salt and brackish
water and
Magnesium

Mg fresh
FRESH WATER ONLY
for freshwater.

SUZUKI™ ANODE KITS

ALL KITS INCLUDE FASTENING HARDWARE, INSTALLATION INSTRUCTIONS,
AND ALL OF THE ANODES REQUIRED FOR 100% PROTECTION.



	PID	LB	KG	Contains	Fits	UPC
Al	CMSZ4050KITA	0.859	0.390	CM5532095310 X 2	Suzuki 40-50 HP	6 28309 24967 0
Mg	CMSZ4050KITM	0.546	0.248	CM5532187J00 X 4		6 28309 24968 7
Zn	CMSZ4050KITZ	1.190	0.540	CM5512595500 X 1		6 28309 24969 4



	PID	LB	KG	Contains	Fits	UPC
Al	CMSZ90140KITA	0.848	0.385	CM5532190J01 X 1	Suzuki 90-100-115 -140 HP	6 28309 24962 5
Mg	CMSZ90140KITM	0.688	0.312	CM5532187J00 X 4		6 28309 24963 2
Zn	CMSZ90140KITZ	1.724	0.782	CM3C7602181A0 X 1		6 28309 24964 9



	PID	LB	KG	Contains	Fits	UPC
Al	CMSZ150350KITA	0.346	0.47	CM3C7602181A0 X 1	Suzuki 150-350 HP	6 28309 27228 9
Mg	CMSZ150350KITM	0.763	0.346	CM5532187J00 X 8		6 28309 27229 6
Zn	CMSZ150350KITZ	2.117	0.96	CM5532095310 X 3		6 28309 27227 2

Martyr®
SUZUKI™ / VOLVO PENTA™ ANODES

NEW
PRODUCTS

VOLVO PENTA™ ANODES

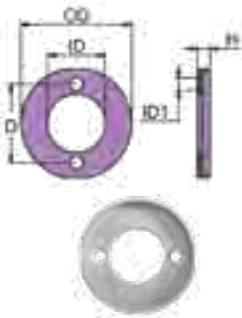

	PID	LB	KG		OD	D	ID	ID1	H	UPC
Al	CMV15A (CM875810A)	0.172	0.078	mm	98.8	69.5	51.2	11	11.5	6 28309 12355 0
Mg	CMV15M (CM875810M)	0.110	0.050							6 28309 19320 1
Zn	CMV15 (CM875810Z)	0.452	0.205	in	3.89	2.74	2.02	0.43	0.45	6 28309 10360 6

50-100 SERIES

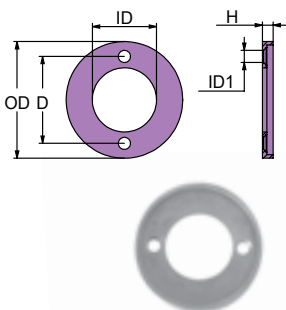

	PID	LB	KG		OD	D	ID	ID1	H	UPC
Al	CMV16A (CM875809A)	0.176	0.080	mm	106	79	58.3	11	10	6 28309 12356 7
Mg	CMV16M (CM875809M)	0.112	0.051							6 28309 19321 8
Zn	CMV16 (CM875809Z)	0.458	0.208	in	4.2	3.1	2.3	0.43	0.4	6 28309 10361 3

50-200 SERIES

VOLVO PENTA™ ANODES

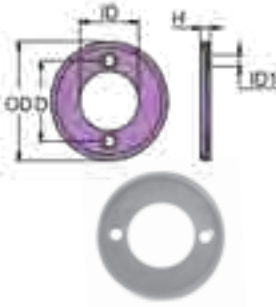

	PID	LB	KG		OD	D	ID	ID1	H	UPC
Al	CMV17A (CM875806-4A)	0.231	0.105	mm	116.5	79	58.3	11	10	6 28309 12357 4
Mg	CMV17M (CM875806-4M)	0.145	0.066							6 28309 19322 5
Zn	CMV17 (CM875806-4Z)	0.606	0.275	in	4.59	3.11	2.3	0.43	0.39	6 28309 10362 0

50-250-270-275-280-285 SERIES



	PID	LB	KG		L	H	D	OD	ID	ID1	UPC
Al	CMV18A (CM875815-3A)	0.64	0.29	mm	155	33.5	80	120	61	9	6 28309 12266 9
Mg	CMV18M (CM875815-3M)	0.4	0.18								6 28309 10364 4
Zn	CMV18 (CM875815-3Z)	1.16	0.73	in	6.1	1.32	3.15	4.72	2.4	0.35	6 28309 10363 7

280-290 E SINGLE DROP SERIES

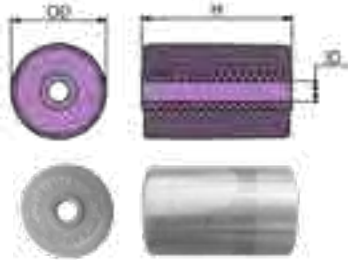

	PID	LB	KG		OD	H	ID	UPC
Al	CM21718129A	0.465	0.211	mm	38.9	61.5	8.3	6 28309 25162 8
Mg	CM21718129M	0.339	0.154					6 28309 25163 5
Zn	CM21718129Z	1.020	0.463	in	1.53	2.42	0.33	6 28309 25161 1

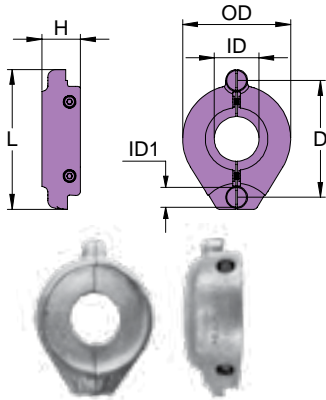

	PID	LB	KG		L	H	D	ID	ID1	OD	UPC
Zn	CM22651246Z	3.213	1.457	mm	141.1	39	118	45	20	109	6 28309 27309 5
				in	5.56	1.54	4.65	1.77	0.79	4.29	

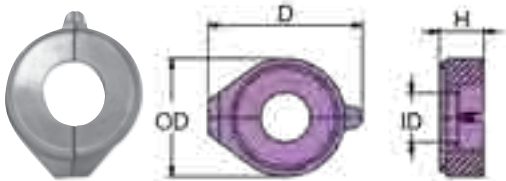

	PID	LB	KG		D	OD	ID	H	UPC
Al	CM358407A	1.338	0.607	mm	139	108	45	40	6 28309 12394 9
Mg	CM358407M	0.893	0.405						6 28309 12404 5
Zn	CM358407Z	3.355	1.522	in	5.47	4.25	1.77	1.57	6 28309 12325 3

SD 130/150 2002 2003 SERIES

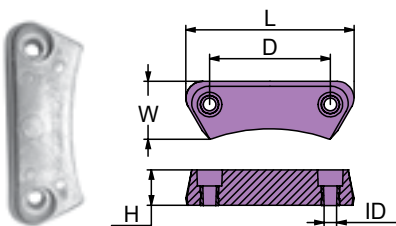

	PID	LB	KG		L	W	H	D	ID	UPC
Al	CM3588745A	0.445	0.202	mm	118	41	25	85	9	6 28309 17066 0
Mg	CM3588745M	0.284	0.129							6 28309 17067 7
Zn	CM3588745Z	1.082	0.491	in	4.6	1.6	1	3.4	0.35	6 28309 17068 4

DUO PROP

Protect your boat, respect our waters.

VOLVO PENTA™ ANODES

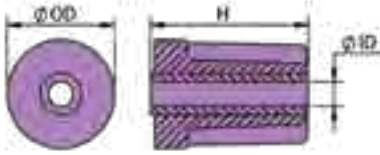

	PID	LB	KG		OD	ID	H	UPC
Al	CM3593881A	0.75	0.34	mm	49.1	10.5	72	6 28309 17069 1
Mg	CM3593881M	0.57	0.26					6 28309 19286 0
Zn	CM3593881Z	1.61	0.73	in	1.93	0.41	2.83	6 28309 17070 7

IPS

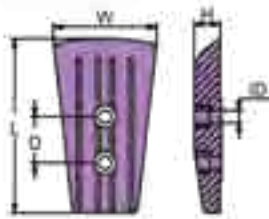

	PID	LB	KG		L	H	W	D	ID	UPC
Al	CM3589875A	0.72	0.33	mm	132.3	19.6	78	35	9.6	6 28309 21147 9
Mg	CM3589875M	0.50	0.23							6 28309 21169 1
Zn	CM3589875Z	1.82	0.83	in	5.20	0.77	3.07	1.38	0.38	6 28309 21148 6

VOLVO PENTA DPR PLATE

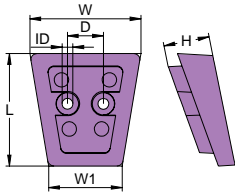
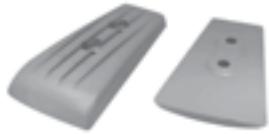

	PID	LB	KG		L	W	W1	H	D	ID	UPC
Al	CM3841427A	0.974	0.442	mm	94	93	61	38	30	9	6 28309 12636 0
Mg	CM3841427M	0.639	0.290								6 28309 15986 3
Zn	CM3841427Z	2.425	1.100	in	3.7	3.7	2.4	1.5	1.18	0.35	6 28309 12734 3

SX-A/APS-A

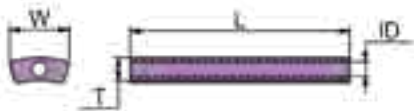

	PID	LB	KG		L	W	ID	T	UPC
Al	CM3852970A	0.150	0.068	mm	104	28	7	11	6 28309 12577 6
Mg	CM3852970M	0.095	0.043						6 28309 19287 7
Zn	CM3852970Z	0.389	0.176	in	4	1.1	0.26	0.42	6 28309 19250 1

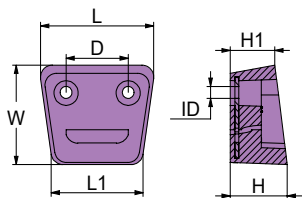

	PID	LB	KG		L	L1	W	H	H1	D	ID	UPC
Al	CM3854130A	0.930	0.422	mm	96	73	80	47	37	51	10	6 28309 12270 6
Mg	CM3854130M	0.613	0.278									6 28309 12608 7
Zn	CM3854130Z	2.319	1.052	in	3.76	2.86	3.14	1.84	1.44	2	0.38	6 28309 11378 0

S. DRIVE - SX DRIVE



Martyr® VOLVO PENTA™ ANODES

VOLVO PENTA™ ANODES

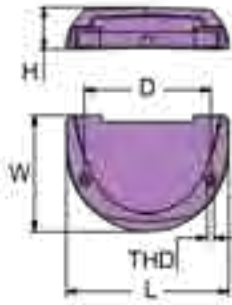

	PID	LB	KG		L	W	H	D	THD	UPC
Al	CM3855411A	0.992	0.450	mm	145	103	37	113	¼ - 20 UNC	6 28309 12269 0
Mg	CM3855411M	0.628	0.285							6 28309 12634 6
Zn	CM3855411Z	2.469	1.120	in	5.7	4	1.4	4.4		6 28309 11372 8

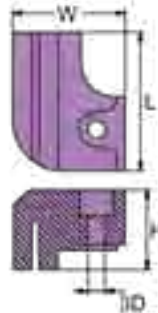

	PID	LB	KG		L	W	H	ID	UPC
Al	CM3861636A	0.214	0.097	mm	52	43	30	6.1	6 28309 17074 5
Mg	CM3861636M	0.136	0.062						6 28309 17075 2
Zn	CM3861636Z	0.520	0.236	in	2	1.7	1.2		0.24

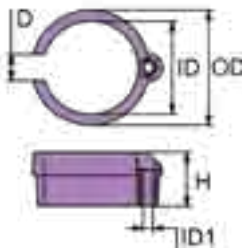

	PID	LB	KG		OD	ID	ID1	D	H	UPC
Al	CM3861634A	0.262	0.119	mm	78	64	6.1	18	37	6 28309 17071 4
Mg	CM3861634M	0.169	0.077							6 28309 17072 1
Zn	CM3861634Z	0.672	0.305	in	3.1	2.52	0.24	0.71		1.5

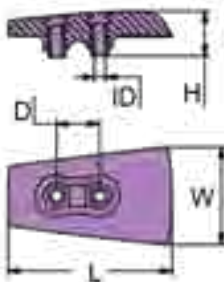

	PID	LB	KG		L	W	H	D	ID	UPC
Al	CM3863206A	0.771	0.350	mm	132	78	36	35	9	6 28309 12722 0
Mg	CM3863206M	0.485	0.220							6 28309 17606 8
Zn	CM3863206Z	1.962	0.890	in	5.2	3.1	1.4	1.4		0.35

DPH/DPR SERIES

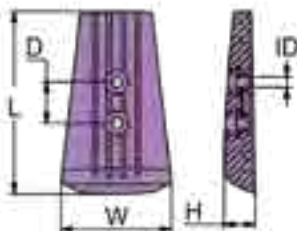

	PID	LB	KG		L	W	H	D	ID	UPC
Al	CM3883728A	1.1	0.5	mm	153	91	27	34.6	9	6 28309 12720 6
Mg	CM3883728M	0.71	0.32							6 28309 15987 0
Zn	CM3883728Z	2.89	1.31	in	6	3.6	1.1	1.36		0.4



VOLVO PENTA™ ANODES

**NEW
PRODUCT**

VOLVO PENTA™ ANODES

Choose Aluminum
Al premium
SALT AND BRACKISH WATER

Anodes for salt and brackish water and Magnesium

Mg fresh
FRESH WATER ONLY
for freshwater.

	PID	LB	KG		L	ID	W	H	W1	D	D1	UPC
Al	CM40005206A	4.63	2.10	mm	346	7.7	72	30	10.6	150	5.5	6 28309 25521 3
Mg	CM40005206M	2.99	1.36									6 28309 25526 8
Zn	CM40005206Z	11.81	5.36	in	13.62	0.30	2.83	1.18	0.42	5.90	0.21	6 28309 25516 9

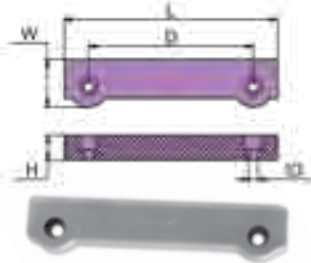
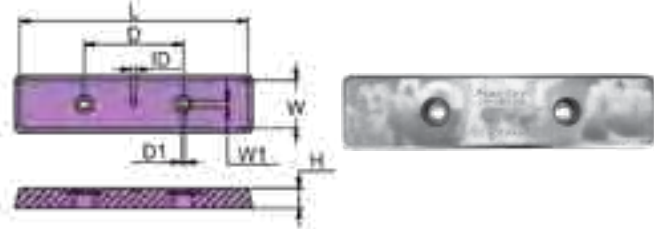

	PID	LB	KG		L	W	H	D	ID	UPC
Al	CM832598A	0.81	0.37	mm	188	41	22	145	8	6 28309 12265 2
Mg	CM832598M	0.52	0.24							6 28309 10125 1
Zn	CM832598Z	2.09	0.95	in	7.4	1.6	0.9	5.7	0.3	6 28309 10126 8

250-270-275-280-285 SERIES

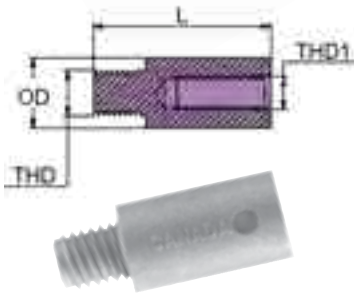

	PID	LB	KG		L	OD	THD	THD1	UPC
Al	CM838929A	0.040	0.018	mm	43	17	7/16	M8	6 28309 12328 4
Mg	CM838929M	0.025	0.011				- 14		6 28309 19298 3
Zn	CM838929Z	0.090	0.041	in	1.7	0.67	UNC		6 28309 10128 2

200-250-270 SERIES

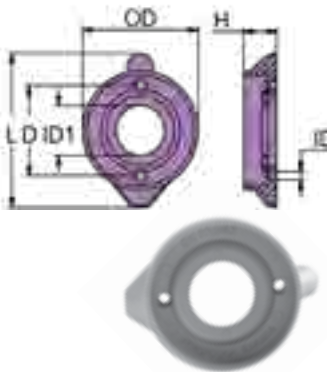

	PID	LB	KG		L	D	OD	ID	ID1	H	UPC
Al	CM851983A	0.441	0.200	mm	124	72.5	96	7	40	27	6 28309 12326 0
Mg	CM851983M	0.286	0.130								6 28309 12190 7
Zn	CM851983Z	1.080	0.490	in	4.9	2.85	3.8	0.26	1.57	1.1	6 28309 10134 3

S. DRIVE 120 SERIES

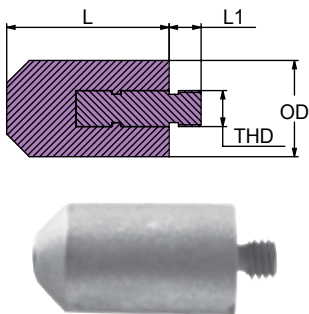

	PID	LB	KG		L	L1	OD	THD	UPC
Al	CM823661A	0.145	0.066	mm	43	9.4	26	3/8 - 16 UNC	6 28309 10118 3
Mg	CM823661M	0.106	0.048						6 28309 12327 7
Zn	CM823661Z	0.308	0.140	in	1.7	0.4	1		6 28309 12374 1

Martyr
VOLVO PENTA™ ANODES

VOLVO PENTA™ ANODES

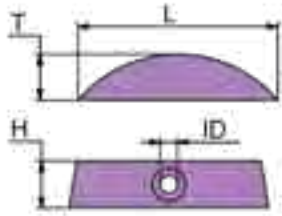

	PID	LB	KG		L	H	T	ID	UPC
Al	CM852018A (CM850982A)	0.044	0.020	mm	64	15	15	5.84	6 28309 11522 7
Mg	CM852018M (CM850982M)	0.028	0.013						6 28309 12330 7
Zn	CM852018Z (CM850982Z)	0.112	0.051	in	2.5	0.59	0.57	0.23	6 28309 19299 0

110-120, S-B, S-C SERIES

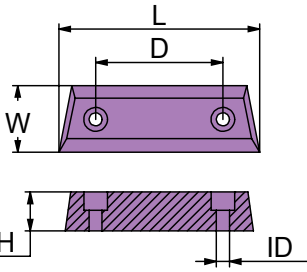

	PID	LB	KG		L	W	H	D	ID	UPC
Al	CM852835A	0.639	0.290	mm	136	46	26	86	9	6 28309 12268 3
Mg	CM852835M	0.423	0.192							6 28309 10135 0
Zn	CM852835Z	1.785	0.810	in	5.35	1.81	1	3.4	0.33	6 28309 10136 7

DUO PROP 290 SERIES

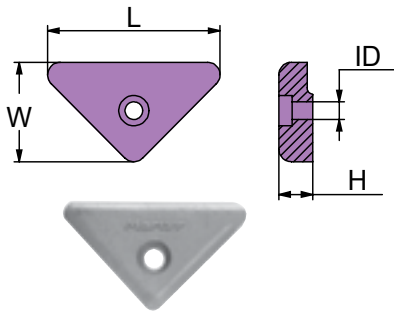

	PID	LB	KG		L	W	H	ID	UPC
Al	CM872793A	0.100	0.045	mm	66	38	13	6	6 28309 12332 1
Mg	CM872793M	0.060	0.027						6 28309 17046 2
Zn	CM872793Z	0.240	0.109	in	2.6	1.5	0.5	0.25	6 28309 11367 4

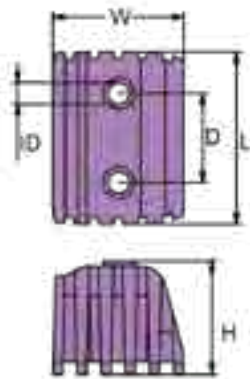

	PID	LB	KG		L	W	H	D	ID	UPC
Al	CM873395A	0.236	0.107	mm	54	41	36	28	6.7	6 28309 12637 7
Mg	CM873395M	0.158	0.072							6 28309 15988 7
Zn	CM873395Z	0.613	0.278	in	2.1	1.6	1.4	1.1	0.24	6 28309 12736 7

DPX SERIES

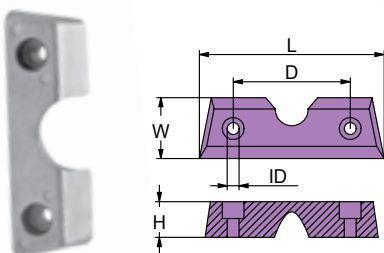

	PID	LB	KG		L	W	H	D	ID	UPC
Al	CM872139A	0.595	0.270	mm	136	46	26	86	9	6 28309 12331 4
Mg	CM872139M	0.374	0.170							6 28309 19301 0
Zn	CM872139Z	1.543	0.700	in	5.35	1.8	1	3.4	0.33	6 28309 11366 7

DPX SERIES

VOLVO PENTA™ ANODES

Protect your boat, respect our waters.

VOLVO PENTA™ ANODES

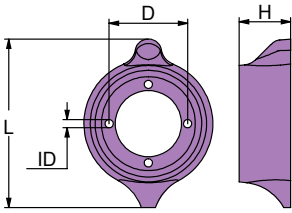

	PID	LB	KG		L	H	D	ID	UPC
Al	CM875812A	0.778	0.353	mm	140	43	65	6	6 28309 12333 8
Mg	CM875812M	0.489	0.222						6 28309 10141 1
Zn	CM875812Z	2.019	0.916	in	5.5	1.7	2.55	0.25	6 28309 10140 4

S. DRIVE 110 SERIES

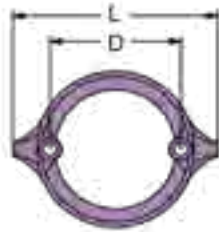

	PID	LB	KG		L	H	D	ID	UPC
Al	CM875821A	0.447	0.203	mm	145	29	92	9	6 28309 12267 6
Mg	CM875821M	0.289	0.131						6 28309 10141 1
Zn	CM875821Z	1.144	0.519	in	5.7	1.2	3.63	0.34	6 28309 10142 8

DUO PROP 290 SERIES



Martyr®
VOLVO PENTA™ ANODES



	PID	LB	KG		L	W	H	D	D1	W1	UPC
Al	CM40005875A	3.19	1.45	mm	268	85	30	138	5	10	6 28309 17079 0
Mg	CM40005875M	1.96	0.89								6 28309 17077 6
Zn	CM40005875Z	8.04	3.65	in	10.5	3.3	1.2	5.4	0.21	0.41	6 28309 17078 3

IPS

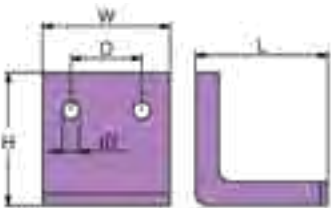
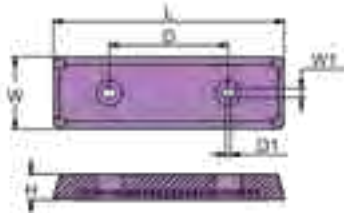

	PID	LB	KG		L	W	H	D	ID	UPC
Al	CM832934A	0.55	0.25	mm	56	56	54	26	9	6 28309 23500 0
Mg	CM832934M	0.35	0.16							6 28309 23501 7
Zn	CM832934Z	1.46	0.66	in	2.2	2.2	2.1	1	0.35	6 28309 23502 4

BRACKET TRIM 270



VOLVO PENTA™ ANODES

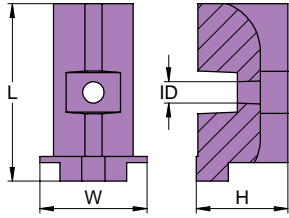

	PID	LB	KG		L	W	H	ID	UPC
Al	CM855105A	0.125	0.057	mm	58	35	29.5	7	6 28309 20943 8
Mg	CM855105M	0.0793	0.036						6 28309 20964 3
Zn	CM855105Z	0.328	0.149	in	2.28	1.38	1.16	0.28	6 28309 20985 8

S. DRIVE SERIES



	PID	LB	KG		OD	H	THD	Shaft	UPC
Al	CM833913A	0.249	0.113	mm	37	70	3/4 - 10 UNC	22-25	6 28309 20961 2
Mg	CM833913M	0.158	0.072						6 28309 20982 7
Zn	CM833913Z	0.643	0.292	in	1.46	2.76			6 28309 20940 7
Al	CM833915A	0.233	0.106	mm	37	70	7/8 - 9 UNC	30	6 28309 20962 9
Mg	CM833915M	0.147	0.067						6 28309 20983 4
Zn	CM833915Z	0.604	0.274	in	1.46	2.76			6 28309 20941 4
Al	CM828140A	0.394	0.179	mm	46	80	1 - 8 UNC	40-45	6 28309 20960 5
Mg	CM828140M	0.251	0.114						6 28309 20981 0
Zn	CM828140Z	1.025	0.465	in	1.81	3.15			6 28309 20939 1

DPX SERIES

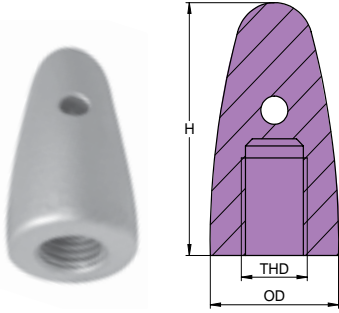

	PID	LB	KG		L	W	H	ID	D	UPC
Al	CM876638A	0.163	0.074	mm	56	60	13	7	27	6 28309 24181 0
Mg	CM876638M	0.139	0.063							6 28309 24291 6
Zn	CM876638Z	0.571	0.259	in	2.2	2.36	0.51	0.28	1.06	6 28309 24114 8

DPX SERIES

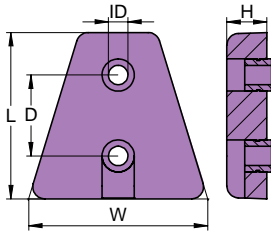

	PID	LB	KG		L	W	H	ID	UPC
Al	SGSP71180A	0.039	0.018	mm	37	22	15	7	6 28309 22627 5
Mg	SGSP71180M	0.024	0.011						6 28309 22847 7
Zn	SGSP71180Z	0.101	0.046	in	1.5	0.9	0.6	0.3	6 28309 22311 3

BOW THRUST



	PID	LB	KG		OD	H	THD	UPC
Al	CM41100098A	0.048	0.022	mm	30	22	M4	6 28309 20953 7
Mg	CM41100098M	0.031	0.014					6 28309 20974 2
Zn	CM41100098Z	0.128	0.058	in	1.2	0.9		6 28309 20932 2

OGIVE BOW THRUST

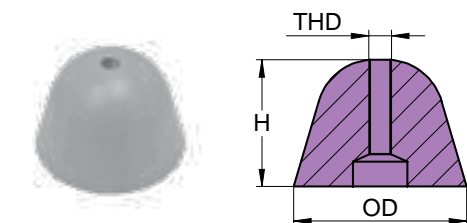
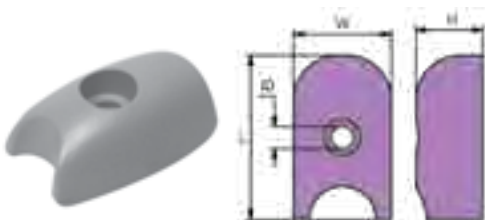

VOLVO PENTA™ ANODES

Choose
Aluminum

Al premium
SALT AND BRACKISH WATER

Anodes for
salt and brackish
water and
Magnesium

Mg fresh
FRESH WATER ONLY
for freshwater.

VOLVO PENTA™ ANODES

	PID	LB	KG		L	W	ID	T	UPC
Al	CM41100276A	0.072	0.033	mm	51	25	7	16	6 28309 23341 9
Mg	CM41100276M	0.046	0.021						6 28309 23342 6
Zn	CM41100276Z	0.187	0.085	in	2	1	0.26	0.62	6 28309 23343 3

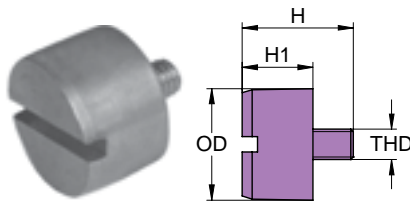
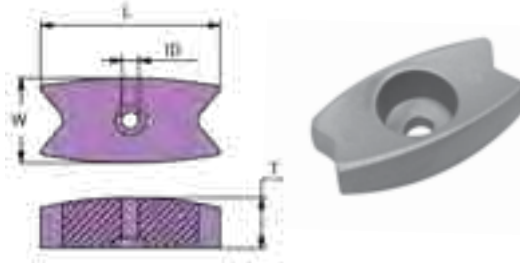

	PID	LB	KG		OD	H	H1	THD	UPC
Al	CM8520219A	0.037	0.017	mm	22	22	14	M6 x 1	6 28309 20963 6
Mg	CM8520219M	0.028	0.013						6 28309 20984 1
Zn	CM8520219Z	0.079	0.036	in	0.9	0.9	0.5		6 28309 20942 1

SEAL DRIVE 100

VOLVO PENTA™ ANODE KITS



	PID	LB	KG	Contains	Fits	UPC
Al	CM280KITA	1.651	0.749	CMV18 X 1 CM832598 X 1	Volvo 280 Engine	6 28309 12286 7
Mg	CM280KITM	1.177	0.534			6 28309 12797 8
Zn	CM280KITZ	3.922	1.779			6 28309 12802 9



	PID	LB	KG	Contains	Fits	UPC
Al	CM280DPKITA	1.708	0.775	CM875821 X 1 CM832598 X 1	Volvo 280 Dual Prop Engine	6 28309 12287 4
Mg	CM280DPKITM	1.300	0.590			6 28309 12798 5
Zn	CM280DPKITZ	3.708	1.682			6 28309 12803 6



	PID	LB	KG	Contains	Fits	UPC
Al	CM290KITA	1.653	0.750	CMV18 X 1	Volvo 290	6 28309 12288 1
Mg	CM290KITM	1.208	0.548			6 28309 12799 2
Zn	CM290KITZ	3.686	1.672	CM852835 X 1	Engine	6 28309 12804 3

Martyr®
VOLVO PENTA™ ANODES

VOLVO PENTA™ ANODE KITS



	PID	LB	KG	Contains	Fits	UPC
Al	CM290DPKITA	1.44	0.65	CM875821 X 1 CM852835 X 1	Volvo 290 Dual Prop Engine	6 28309 12289 8
Mg	CM290DPKITM	1.067	0.484			6 28309 12800 5
Zn	CM290DPKITZ	3.285	1.490			6 28309 12805 0



	PID	LB	KG	Contains	Fits	UPC
Al	CMDPHKITA	1.748	0.793	CM3588745 X 1 CM3863206 X 1	Volvo DPH Engine	6 28309 17047 9
Mg	CMDPHKITM	1.340	0.608			6 28309 17048 6
Zn	CMDPHKITZ	3.532	1.602			6 28309 17049 3



	PID	LB	KG	Contains	Fits	UPC
Al	CMSXKITA	2.27	1.03	CM3855411 X 1 CM3854130 X 1	Volvo SX Engine	6 28309 12290 4
Mg	CMSXKITM	1.633	0.741			6 28309 12801 2
Zn	CMSXKITZ	5.176	2.348			6 28309 12806 7



	PID	LB	KG	Contains	Fits	UPC
Al	CMSXAKITA	2.38	1.08	CM3841427 X 1 CM3883728 X 1	Volvo SX-A/DPS Engine	6 28309 17050 9
Mg	CMSXAKITM	1.67	0.76			6 28309 17051 6
Zn	CMSXAKITZ	5.62	2.55			6 28309 17052 3



	PID	LB	KG	Contains	Fits	UPC
Al	CM3858399KITA	0.401	0.182	CM3858286 X 3	Volvo Folding Prop 3-blade Engine D2-55A, B, C, D, E, F	6 28309 15934 4
Mg	CM3858399KITM	0.324	0.147			6 28309 15935 1
Zn	CM3858399KITZ	0.782	0.355			6 28309 15933 7

VOLVO PENTA™ ANODES

Protect your boat, respect our waters.

VOLVO PENTA™ ANODE KITS



	PID	LB	KG	Contains	Fits	UPC
Al	CM290EUKITA	1.85	0.84	CMV18 X 1 CM852835 X 1 CM872793 X 2	Fits Volvo Penta 290	6 28309 25508 4
Mg	CM290EUKITM	1.32	0.60			6 28309 25509 1
Zn	CM290EUKITZ	3.74	1.70			6 28309 25510 7



	PID	LB	KG	Contains	Fits	UPC
Al	CM290DPEUKITA	1.67	0.76	CM875821 X 1 CM852835 X 1 CM872793 X 1	Fits Volvo Penta 290DP	6 28309 25505 3
Mg	CM290DPEUKITM	1.23	0.56			6 28309 25506 0
Zn	CM290DPEUKITZ	2.2	0.54			6 28309 25507 7



	PID	LB	KG	Contains	Fits	UPC
Al	CM3584442KITA	0.410	0.186	CM3584442D X 3	Volvo 4-Blade Folding Prop	6 28309 25511 4
Mg	CM3584442KITM	0.313	0.142			6 28309 25512 1
Zn	CM3584442KITZ	0.796	0.361			6 28309 25513 8



	PID	LB	KG	Contains	Fits	UPC
Al	CM872793KITA	0.2	0.09	CM872793 X 2	Fits Volvo Penta 290, 290DP, XDP & DPX	6 28309 18957 0
Mg	CM872793KITM	0.12	0.054			6 28309 18958 7
Zn	CM872793KITZ	0.48	0.22			6 28309 18959 4



	PID	LB	KG	Contains	Fits	UPC
Al	CMVPIPSKITA	4.18	1.90	CM3593881 X 1 CM40005875 X 1	Volvo Penta IPS SternDrive	6 28309 26012 5
Mg	CMVPIPSKITM	2.77	1.26			6 28309 26034 7
Zn	CMVPIPSKITZ	9.86	4.48			6 28309 25988 4

YAMAHA™ ANODES

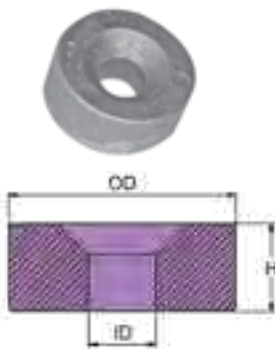

	PID	LB	KG		OD	ID	H	UPC
Al	CM41106ZW000A	0.0149	0.0067	mm	22	6.5	8.5	6 28309 23347 1
Mg	CM41106ZW000M	0.0095	0.0043					6 28309 23348 8
Zn	CM41106ZW000Z	0.0386	0.0175	in	0.86	0.25	0.33	6 28309 23349 5

2 - 115 HP / MARINER 2 - 25 HP / YAMAHA 2 - 25 HP

YAMAHA™ ANODES

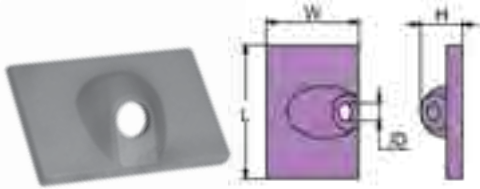

	PID	LB	KG		L	W	H	ID	UPC
Al	CM42121A	0.024	0.011	mm	42	29	11	7	6 28309 20954 4
Mg	CM42121M	0.015	0.007						6 28309 20975 9
Zn	CM42121Z	0.059	0.027	in	1.66	1.1	0.42	0.28	6 28309 20933 9

6-9.9 HP MARINER

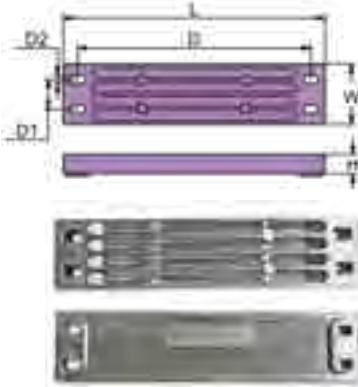

	PID	LB	KG		L	W	H	D	D1	D2	UPC
Al	CM6AW4525100A	0.56	0.25	mm	203	47	15	180.35	23	6.2	6 28309 25540 4
Mg	CM6AW4525100M	0.35	0.16								6 28309 25545 9
Zn	CM6AW4525100Z	1.46	0.66	in	7.99	1.85	0.59	7.1	0.90	0.24	6 28309 25535 0

YAMAHA OB ENGINE ANODE 6AW-45251-00

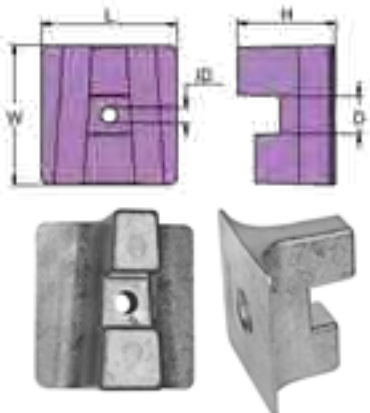

	PID	LB	KG		L	W	H	ID	D	UPC
Al	CM6AW4537300A	0.93	0.42	mm	90	93	35.5	11	25	6 28309 25541 1
Mg	CM6AW4537300M	0.59	0.27							6 28309 25546 6
Zn	CM6AW4537300Z	2.42	1.09	in	3.54	3.66	1.39	0.43	0.98	6 28309 25536 7

YAMAHA OB ENGINE ANODE 6AW-45373-00

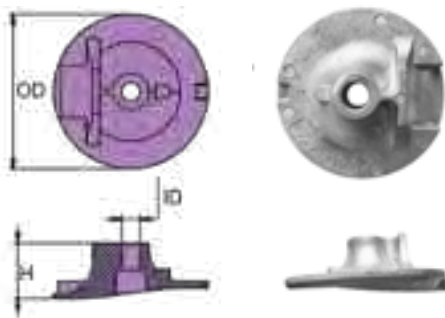

	PID	LB	KG		OD	ID	H	UPC
Al	CM6AW4561900A	0.227	0.103	mm	88.9	10.5	32	6 28309 25995 2
Mg	CM6AW4561900M	0.145	0.066					6 28309 26019 4
Zn	CM6AW4561900Z	0.595	0.27	in	3.5	0.41	1.26	6 28309 25972 3

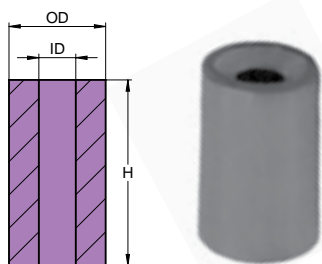

	PID	LB	KG		OD	ID	H	UPC
Al	CM6BL1132500A	0.015	0.007	mm	13	5	25	6 28309 23215 3
Mg	CM6BL1132500M	0.009	0.004					6 28309 23229 0
Zn	CM6BL1132500Z	0.04	0.02	in	0.51	0.2	1	6 28309 23198 9

YAMAHA™ ANODES

**NEW
PRODUCTS**

Choose
Aluminum

Al premium
SALT AND BRACKISH WATER

Anodes for
salt and brackish
water and
Magnesium

Mg fresh
FRESH WATER ONLY
for freshwater.

YAMAHA™ ANODES

PID		LB	KG		L	W	H	D	THD	UPC
Al	CM6E04525111A	0.086	0.039	mm	64	25	14	26	M6 x 1	28309 12647 6
Mg	CM6E04525111M	0.055	0.025							28309 12648 3
Zn	CM6E04525111Z	0.209	0.095	in	2.5	1	0.5	1		28309 10069 8

YAMAHA 40 HP / YAMAHA 4 - 6 - 8 - 9,9 - 15 HP UP TO 1989
ALSO APPLY TO ALLPASS & PAINIER

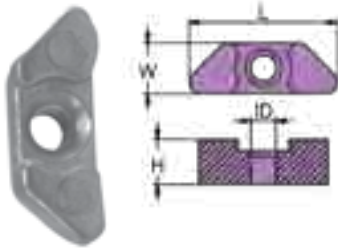
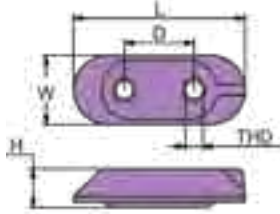

PID		LB	KG		L	W	H	ID	UPC
Al	CM6E51132500A	0.009	0.0040	mm	27	9	10	5	28309 23162 0
Mg	CM6E51132500M	0.006	0.0025						28309 23176 7
Zn	CM6E51132500Z	0.023	0.0104	in	1.1	0.4	0.4	0.2	28309 23150 7

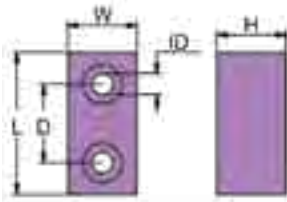

PID		LB	KG		L	W	H	D	ID	UPC
Al	CM6E54525100A	0.112	0.051	mm	47	23	23	23	7	28309 12649 0
Mg	CM6E54525100M	0.077	0.035							28309 12650 6
Zn	CM6E54525100Z	0.291	0.132	in	1.8	0.9	0.9	0.9	0.26	28309 10071 1

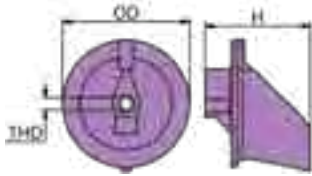

PID		LB	KG		OD	H	THD	UPC
Al	CM6E54537101A	0.346	0.157	mm	92	76	M10x1.25	28309 12651 3
Mg	CM6E54537101M	0.233	0.106					28309 12652 0
Zn	CM6E54537101Z	0.915	0.415	in	3.6	3		28309 10072 8

YAMAHA 150 - 200 HP

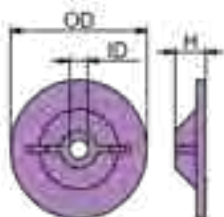

PID		LB	KG		OD	ID	H	UPC
Al	CM6E84525100A	0.048	0.022	mm	45	6.5	11	28309 2388 7
Mg	CM6E84525100M	0.031	0.014					28309 23886 5
Zn	CM6E84525100Z	0.130	0.059	in	1.77	0.26	0.43	28309 23877 3

9.9 HP

Martyr
YAMAHA™ ANODES

YAMAHA™ ANODES

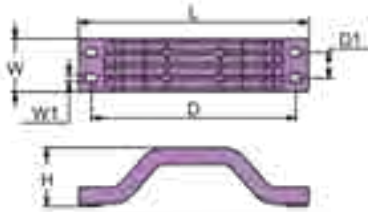

	PID	LB	KG		L	W	W1	H	D	D1	UPC
Al	CM6G54525101A	0.736	0.334	mm	203	47	6.2	52	180.35	23	6 28309 12655 1
Mg	CM6G54525101M	0.465	0.211								6 28309 12656 8
Zn	CM6G54525101Z	1.825	0.828	in	7.99	1.85	0.24	2.05	7.1	0.91	6 28309 10075 9

V6 UP TO 1989 / YAMAHA 115 - 130 - 150 - 175 - 200 - 225 - 250 HP

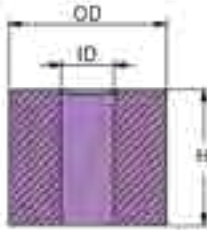

	PID	LB	KG		OD	ID	H	UPC
Al	CM6G81132500A	0.0088	0.004	mm	13.95	5.2	15	6 28309 23163 7
Mg	CM6G81132500M	0.0055	0.0025					6 28309 23177 4
Zn	CM6G81132500Z	0.0229	0.0104	in	0.55	0.2	0.59	6 28309 23151 4

4 - 6 - 8 - 9 - 9,9 - 15 - 20 - 25 - 30 - 40 - 50 - 60 - 70 HP

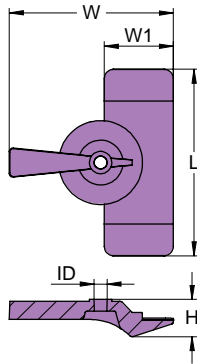

	PID	LB	KG		L	W	W1	H	ID	UPC
Al	CM6G84525101A	0.176	0.080	mm	100	88	37	20	7	6 28309 23428 7
Mg	CM6G84525101M	0.112	0.051							6 28309 23429 4
Zn	CM6G84525101Z	0.458	0.208	in	3.9	3.46	1.46	0.79	0.27	6 28309 23430 0

9.9 HP



	PID	LB	KG		L	W	H	D	ID	UPC
Al	CM6H14525101A	0.513	0.233	mm	205	36	17	188	8	6 28309 21159 2
Mg	CM6H14525101M	0.328	0.149							6 28309 21180 6
Zn	CM6H14525101Z	1.300	0.590	in	8	1.42	0.67	7.4	0.31	6 28309 21135 6

YAMAHA 40 - 50 - 55 - 70 - 85 - 90 HP

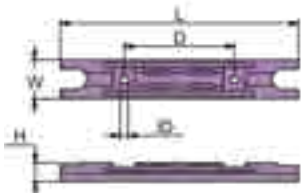

	PID	LB	KG		L	W	H	D	ID	UPC
Al	CM6H14525102A	0.43	0.2	mm	203	36	17	101	7	6 28309 12657 5
Mg	CM6H14525102M	0.27	0.12							6 28309 12658 2
Zn	CM6H14525102Z	1.08	0.49	in	8	1.4	0.7	4	0.28	6 28309 10076 6

YAMAHA 60 - 70 - 75 - 80 - 90 - 100 HP
ALSO APPLY TO PARSUN & ALLPASS



YAMAHA™ ANODES

YAMAHA™ ANODES

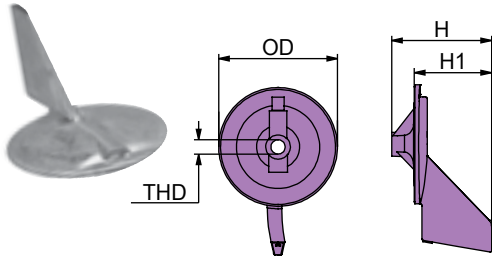

	PID	LB	KG		OD	H	H1	THD	UPC
Al	CM6J94537101A	0.551	0.250	mm	100	84	65	M10x 1.25	6 28309 12659 9
Mg	CM6J94537101M	0.348	0.158						6 28309 12369 7
Zn	CM6J94537101Z	1.369	0.621	in	3.9	3.3	2.6		6 28309 12351 2

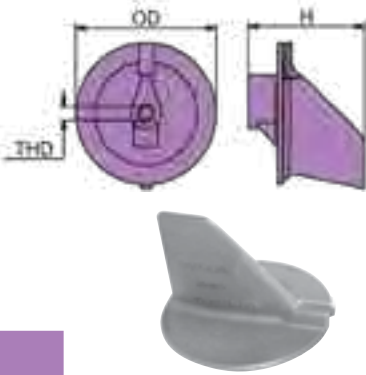

	PID	LB	KG		OD	H	THD	UPC
Al	CM6K14537100A	0.348	0.158	mm	92	76	M10x1.25	6 28309 12653 7
Mg	CM6K14537100M	0.233	0.106					6 28309 12654 4
Zn	CM6K14537100Z	0.897	0.407	in	3.6	3		6 28309 10079 7

COUNTER ROTATION TO CM6E54537101

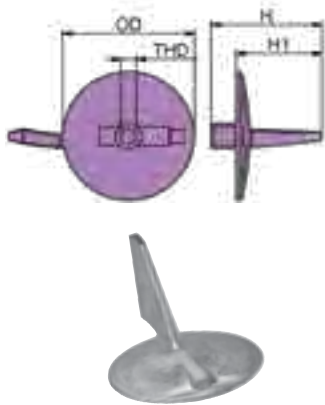

	PID	LB	KG		OD	H	H1	THD	UPC
Al	CM6K14537102A	0.531	0.241	mm	100	84	65	M10 x1.25	6 28309 12660 5
Mg	CM6K14537102M	0.335	0.152						6 28309 12661 2
Zn	CM6K14537102Z	1.380	0.626	in	3.9	3.3	2.6		6 28309 12352 9

COUNTER ROTATION TO CM6J94537101

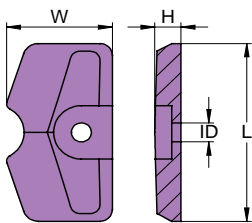

	PID	LB	KG		L	W	H	ID	UPC
Al	CM6L54525102A	0.059	0.027	mm	60	34	8.5	6.4	6 28309 18520 6
Mg	CM6L54525102M	0.037	0.017						6 28309 18521 3
Zn	CM6L54525102Z	0.154	0.070	in	2.36	1.34	0.33	0.25	6 28309 18513 8

ALSO APPLY TO PARSUN

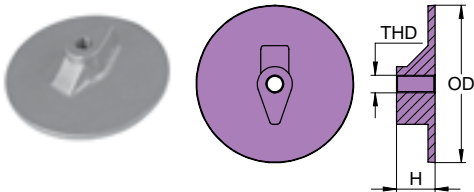

	PID	LB	KG		OD	H	THD	UPC
Al	CM6E54537110A	0.198	0.090	mm	90	22	M10x 1.25	6 28309 23413 3
Mg	CM6E54537110M	0.125	0.057					6 28309 23414 0
Zn	CM6E54537110Z	0.518	0.235	in	3.5	0.87		6 28309 23415 7

YAMAHA 60 -70 -80 -90 - 115 -130 -150 -175 -200 -225 - HP

Martyr®
YAMAHA™ ANODES

YAMAHA™ ANODES

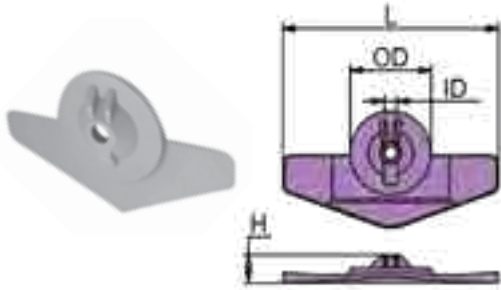

	PID	LB	KG		L	H	ID	OD	UPC
Al	CM6E84525102A	0.132	0.060	mm	100	20	7	45	6 28309 23419 5
Mg	CM6E84525102M	0.083	0.038						6 28309 23420 1
Zn	CM6E84525102Z	0.344	0.156	in	3.93	0.78	0.27	1.8	6 28309 23421 8

9.9-15 HP

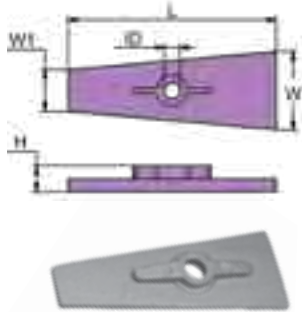

	PID	LB	KG		L	W	W1	H	ID	UPC
Al	CM6G14525102A	0.024	0.011	mm	78	30	14	6	7	6 28309 23422 5
Mg	CM6G14525102M	0.015	0.007							6 28309 23423 2
Zn	CM6G14525102Z	0.066	0.030	in	3.07	1.18	0.55	0.24	0.28	6 28309 23424 9

6-8 HP UP TO 1989

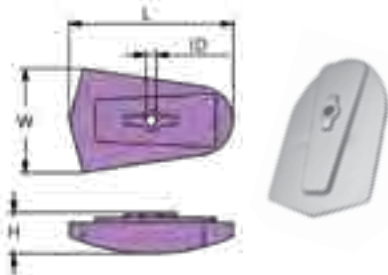

	PID	LB	KG		L	W	H	ID	UPC
Al	CM6G14525103A	0.167	0.076	mm	99	58	12.4	6.4	6 28309 23425 6
Mg	CM6G14525103M	0.106	0.048						6 28309 23426 3
Zn	CM6G14525103Z	0.438	0.199	in	3.9	2.28	0.49	0.25	6 28309 23427 0

YAMAHA 6 HP UP TO 2000 - 8 HP

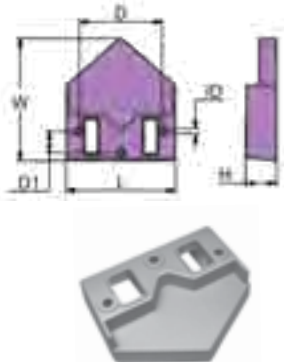

	PID	LB	KG		L	W	H	D	D1	ID	UPC
Al	CM6T44583600A	1.181	0.536	mm	150	130	39	118	25	9	6 28309 24977 9
Mg	CM6T44583600M	0.749	0.340								6 28309 24979 3
Zn	CM6T44583600Z	3.082	1.398	in	5.9	5.1	1.54	4.65	0.98	0.35	6 28309 23460 7

v8

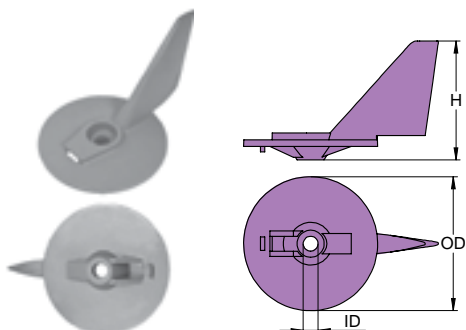

	PID	LB	KG		OD	ID	H	UPC
Al	CM6T54537100A	0.441	0.200	mm	99	11	88	6 28309 24978 6
Mg	CM6T54537100M	0.279	0.127					6 28309 24980 9
Zn	CM6T54537100Z	1.153	0.523	in	3.9	0.43	3.46	6 28309 23463 8

130-160 HP

Choose
Aluminum

Al premium
SALT AND BRACKISH WATER

Anodes for
salt and brackish
water and
Magnesium

Mg fresh
FRESH WATER ONLY
for freshwater.

YAMAHA™ ANODES

	PID	LB	KG		L	W	H	D	THD	UPC
Al	CM6T54537300A	0.84	0.38	mm	138	155	33	64	M8x1.25	6 28309 23464 5
Mg	CM6T54537300M	0.53	0.24							6 28309 23465 2
Zn	CM6T54537300Z	2.18	0.99	in	5.43	6.10	1.30	2.52		6 28309 23466 9

130-260 HP
YAMAHA STERN DRIVE 1989

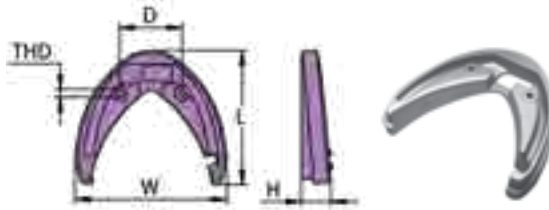

	PID	LB	KG		L	W	H	D	D1	D2	ID	UPC
Al	CM6U04525100A	1.31	0.59	mm	230	130	30	146	35	27	7	6 28309 23216 0
Mg	CM6U04525100M	0.83	0.38									6 28309 23230 6
Zn	CM6U04525100Z	3.3	1.5	in	9	5.1	1.18	5.75	1.37	1.06	0.26	6 28309 23199 6

YAMAHA TD IN OUTBOARDS

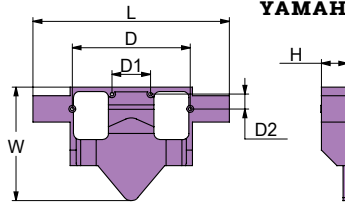

	PID	LB	KG		L	W	H	D	ID	UPC
Al	CM6U34525101A	0.242	0.110	mm	100	45.7	32.5	28	9	6 28309 23467 6
Mg	CM6U34525101M	0.154	0.070							6 28309 23468 3
Zn	CM6U34525101Z	0.630	0.286	in	3.94	1.80	1.28	1.10	0.35	6 28309 23469 0

YAMAHA TD IN OUTBOARDS

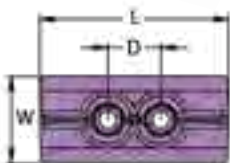

	PID	LB	KG		L	W	H	D	ID	UPC
Al	CM6U44525100A	0.333	0.151	mm	188	45.7	32.5	76	9	6 28309 23470 6
Mg	CM6U44525100M	0.525	0.238							6 28309 23471 3
Zn	CM6U44525100Z	1.369	0.621	in	7.4	1.8	1.28	2.99	0.35	6 28309 23472 0



Martyr®
YAMAHA™ ANODES

YAMAHA™ ANODES

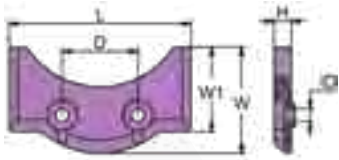

	PID	LB	KG		L	W1	W	H	D	ID	UPC
Al	CM6U44537300A	0.295	0.134	mm	120	56	70	11.5	50	8.5	6 28309 23473 7
Mg	CM6U44537300M	0.187	0.085								6 28309 23474 4
Zn	CM6U44537300Z	0.771	0.350	in	4.72	2.2	2.75	0.45	1.97	0.33	6 28309 23475 1

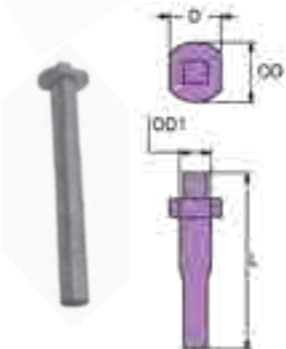

	PID	LB	KG		L	OD	OD1	D	UPC
Al	CM61A1132500A	0.017	0.008	mm	68	16	8	12.6	6 28309 23392 1
Mg	CM61A1132500M	0.011	0.005						6 28309 23393 8
Zn	CM61A1132500Z	0.044	0.020	in	2.68	0.63	0.31	0.5	6 28309 23397 6

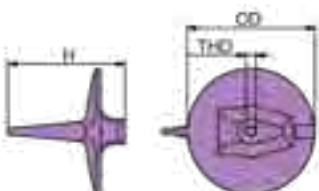

	PID	LB	KG		OD	H	THD	UPC
Al	CM61A4537100A	0.602	0.273	mm	99	91	M10x1.25	6 28309 12641 4
Mg	CM61A4537100M	0.379	0.172					6 28309 12642 1
Zn	CM61A4537100Z	1.492	0.677	in	3.6	3.9		6 28309 11521 0

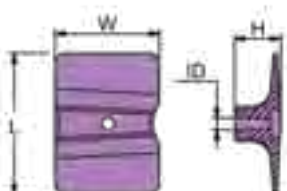

	PID	LB	KG		L	W	H	ID	UPC
Al	CM61N4525101A	0.216	0.098	mm	80	59	26	6.2	6 28309 12666 7
Mg	CM61N4525101M	0.147	0.067						6 28309 12667 4
Zn	CM61N4525101Z	0.579	0.263	in	3.15	2.32	1.02	0.24	6 28309 11518 0



YAMAHA 8 - 9,9 - 13 - 25 - 60 HP
ALSO APPLY TO PARSUN, ALLPASS, HIDEA, TIGER, PAINIER & SHENFENG

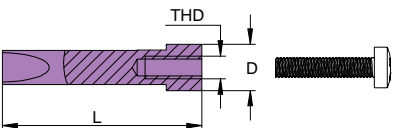

	PID	LB	KG		L	D	THD	UPC
Al	CM62Y1132500A	0.024	0.011	mm	49	11.4	M5 x0.8	6 28309 21133 2
Mg	CM62Y1132500M	0.019	0.009					6 28309 21157 8
Zn	CM62Y1132500Z	0.046	0.021	in	1.9	0.45		6 28309 21178 3



ALSO APPLY TO PARSUN

YAMAHA™ ANODES

YAMAHA™ ANODES

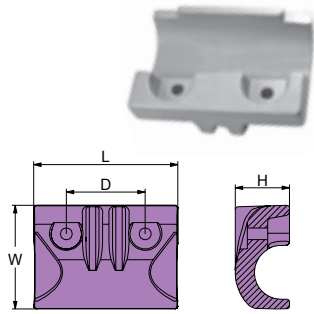

	PID	LB	KG		L	W	H	D	ID	UPC
Al	CM63D4525101A	0.483	0.219	mm	86	62	32	47	7	6 28309 19528 1
Mg	CM63D4525101M	0.306	0.139							6 28309 19529 8
Zn	CM63D4525101Z	1.259	0.571	in	3.4	2.4	1.3	1.9	0.3	6 28309 19530 4



	PID	LB	KG		L	W	H	ID	UPC
Al	CM63P1132501A	0.017	0.008	mm	32	13	10	7	6 28309 23398 3
Mg	CM63P1132501M	0.011	0.005						6 28309 23399 0
Zn	CM63P1132501Z	0.048	0.022	in	1.26	0.51	0.39	0.28	6 28309 23400 3

YAMAHA 150 - 200 - 225 - 250 - 300 - 350 HP

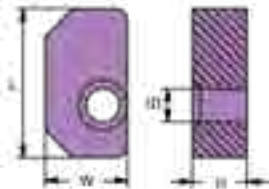

	PID	LB	KG		L	W	H	ID	UPC
Al	CM63P1132511A	0.017	0.008	mm	27	15	10	7	6 28309 23880 3
Mg	CM63P1132511M	0.011	0.005						6 28309 23881 0
Zn	CM63P1132511Z	0.044	0.020	in	1.06	0.59	0.39	0.28	6 28309 23876 6

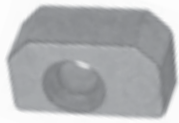

	PID	LB	KG		L	OD	THD	UPC
Al	CM66M1132500A	0.011	0.005	mm	31.6	11	M5 x 0.8	6 28309 23156 9
Mg	CM66M1132500M	0.006	0.003					6 28309 23170 5
Zn	CM66M1132500Z	0.028	0.013	in	1.24	0.43		6 28309 23144 6

YAMAHA 9,9 - 15 - 200 - 225 - 250 - 300 HP

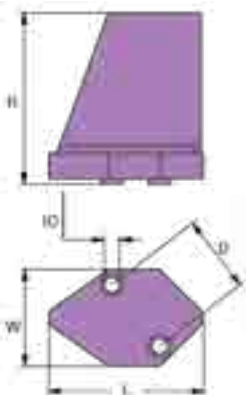

	PID	LB	KG		L	W	H	D	ID	UPC
Al	CM66M4537100A	0.079	0.036	mm	53	38	65	31	7	6 28309 23401 0
Mg	CM66M4537100M	0.050	0.023							6 28309 23402 7
Zn	CM66M4537100Z	0.207	0.094	in	2.1	1.5	2.6	1.22	0.28	6 28309 23403 4

YAMAHA 9,9 - 15 HP



Martyr™
YAMAHA™ ANODES

YAMAHA™ ANODES

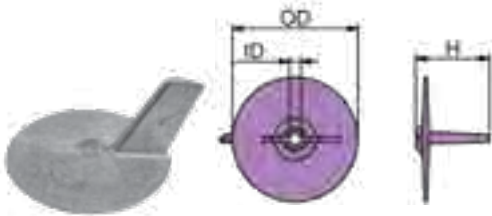

	PID	LB	KG		OD	H	ID	UPC
Al	CM6644537101A	0.238	0.108	mm	96	57	8.5	6 28309 12643 8
Mg	CM6644537101M	0.154	0.070					6 28309 10064 3
Zn	CM6644537101Z	0.639	0.290	in	3.78	2.24	0.33	6 28309 10065 0

ALSO APPLY TO PARSUN, ALLPASS, HIDEA, TIGER, PAINIER & SHENFENG

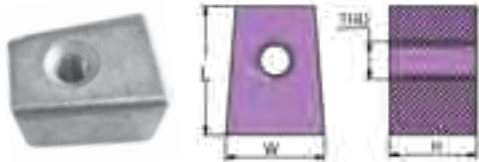

	PID	LB	KG		L	W	H	THD	UPC
Al	CM67C4525100A	0.103	0.047	mm	34.5	26.5	23.5	M8 x1.25	6 28309 20957 5
Mg	CM67C4525100M	0.066	0.030						6 28309 20978 0
Zn	CM67C4525100Z	0.260	0.118	in	1.36	1.04	0.93		6 28309 20936 0

OUTBOARD

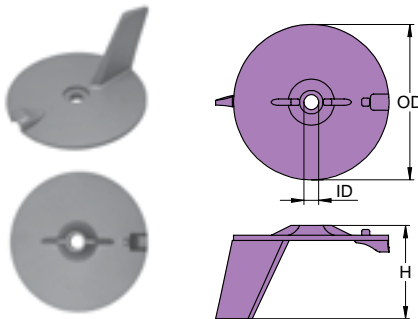

	PID	LB	KG		OD	ID	H	UPC
Al	CM67C4537100A	0.2	0.09	mm	95	9	57	6 28309 21158 5
Mg	CM67C4537100M	0.11	0.05					6 28309 21179 0
Zn	CM67C4537100Z	0.46	0.21	in	3.7	0.35	2.2	6 28309 21134 9

F25 - F30 - F40 - F50 - F60

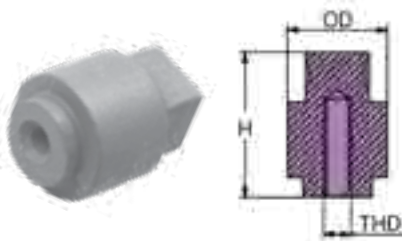

	PID	LB	KG		OD	H	THD	UPC
Al	CM67F1132500A	0.055	0.025	mm	22	32	M6 x 1	6 28309 26356 0
Mg	CM67F1132500M	0.035	0.016					6 28309 26357 7
Zn	CM67F1132500Z	0.123	0.056	in	0.9	1.3		6 28309 23409 6

80-100 HP

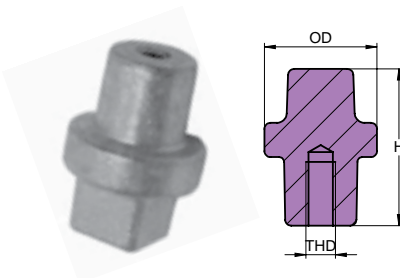

	PID	LB	KG		OD	H	THD	UPC
Al	CM67F1132501A	0.037	0.017	mm	23	32	M6 x 1	6 28309 23407 2
Mg	CM67F1132501M	0.0242	0.011					6 28309 23408 9
Zn	CM67F1132501Z	0.097	0.044	in	0.9	1.26		6 28309 23409 6

YAMAHA™ ANODES

Choose
Aluminum

Al premium
SALT AND BRACKISH WATER

Anodes for
salt and brackish
water and
Magnesium

Mg fresh
FRESH WATER ONLY
for freshwater.

YAMAHA™ ANODES

	PID	LB	KG		OD	H	THD	UPC
Al	CM67F4537100A	0.344	0.156	mm	91	74	M10 x 1.25	6 28309 23410 2
Mg	CM67F4537100M	0.218	0.099					6 28309 23411 9
Zn	CM67F4537100Z	0.897	0.407	in	3.58	2.91		6 28309 23412 6

YAMAHA V6 - 60 - 70 - 75 - 85 - 90 -115 -130 -150 -175 -200 -225 HP

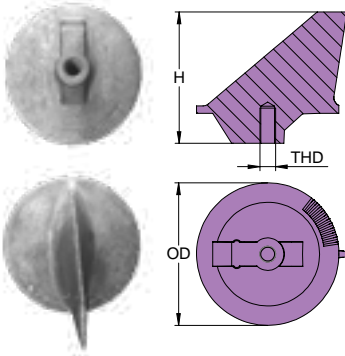
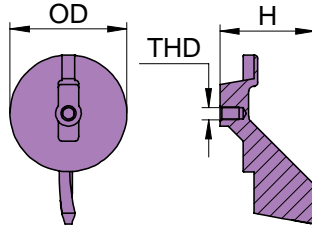

	PID	LB	KG		OD	H	THD	UPC
Al	CM6794525100A	0.470	0.213	mm	90	85	M10 x 1.25	6 28309 23404 1
Mg	CM6794525100M	0.297	0.135					6 28309 23405 8
Zn	CM6794525100Z	1.224	0.555	in	3.6	3.3		6 28309 23406 5

MARINER 40 - 60 HP 10 x 1,25 / MARINER 40 - 60 HP 7/16" /
YAMAHA 55 HP 10 x 1,25

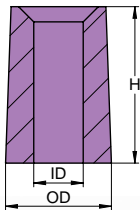

	PID	LB	KG		OD	ID	H	UPC
Al	CM68T1132500A	0.009	0.004	mm	13.5	6.3	20	6 28309 24174 2
Mg	CM68T1132500M	0.006	0.003					6 28309 24284 8
Zn	CM68T1132500Z	0.024	0.011	in	0.53	0.25	0.79	6 28309 24107 0

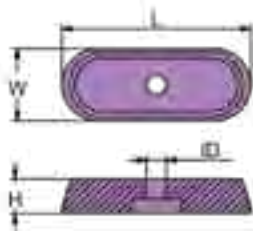

	PID	LB	KG		L	W	H	ID	UPC
Al	CM68T4525100A	0.088	0.040	mm	64	25	12	7	6 28309 19297 6
Mg	CM68T4525100M	0.055	0.025						6 28309 18439 1
Zn	CM68T4525100Z	0.220	0.100	in	2.5	1	0.5	0.3	6 28309 17662 4

YAMAHA F6 - F8 - F9,9
ALSO APPLY TO HIDEA & TIGER

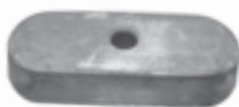

Martyr
YAMAHA™ ANODES

YAMAHA™ ANODES

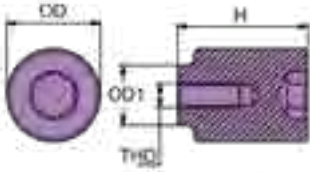

	PID	LB	KG		OD	OD1	H	THD	UPC
Al	CM68V1132501A	0.064	0.029	mm	23	15	32	M6 x 1	6 28309 12256 0
Mg	CM68V1132501M	0.039	0.018						6 28309 21031 1
Zn	CM68V1132501Z	0.167	0.076	in	0.9	0.6	1.26		6 28309 18126 0

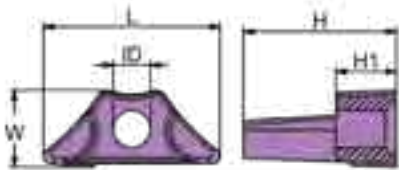

	PID	LB	KG		L	W	H	H1	ID	UPC
Al	CM6881132500A	0.008	0.0036	mm	23	10	20	8	5	6 28309 23161 3
Mg	CM6881132500M	0.005	0.0023							6 28309 23175 0
Zn	CM6881132500Z	0.020	0.0092	in	0.9	0.4	0.8	0.3	0.2	6 28309 18524 4

YAMAHA 40 - 50 - 75 - 80 - 85 - 90 HP

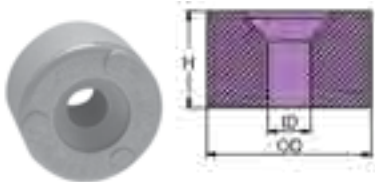

	PID	LB	KG		OD	ID	H	UPC
Al	CM6884525101A	0.028	0.013	mm	24	6.4	14	6 28309 12644 5
Mg	CM6884525101M	0.019	0.009					6 28309 12645 2
Zn	CM6884525101Z	0.079	0.036	in	0.9	0.25	0.55	6 28309 10066 7

2 - 115 HP / MARINER 40 HP / YAMAHA 70 - 85 HP

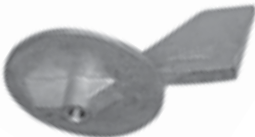
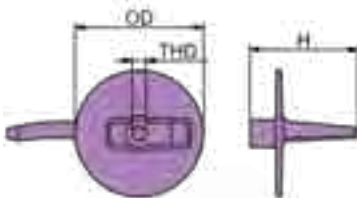

	PID	LB	KG		OD	H	THD	UPC
Al	CM6884537102A	0.392	0.178	mm	92	77	M10x1.25	6 28309 12646 9
Mg	CM6884537102M	0.247	0.112					6 28309 10067 4
Zn	CM6884537102Z	0.976	0.443	in	3.6	3		6 28309 10068 1

YAMAHA 50 - 60 - 70 - 75 - 80 - 85 - 90 HP
ALSO APPLY TO PARSUN & PAINIER

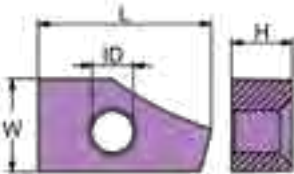

	PID	LB	KG		L	W	H	ID	UPC
Al	CM6891132500A	0.015	0.0069	mm	28	15	10	6.6	6 28309 23161 3
Mg	CM6891132500M	0.009	0.0044						6 28309 23175 0
Zn	CM6891132500Z	0.039	0.018	in	1.1	0.59	0.39	0.26	6 28309 23149 1

ALSO APPLY TO PARSUN

YAMAHA™ ANODES

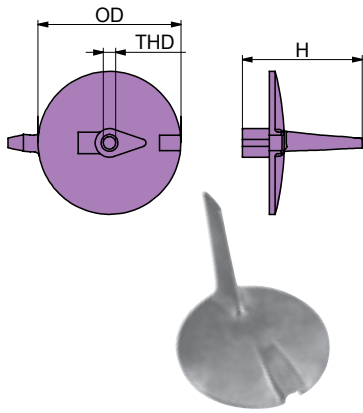

YAMAHA™ ANODES

	PID	LB	KG		OD	H	THD	UPC
Al	CM69L4537100A	0.485	0.220	mm	99	91	M10 x1.25	6 28309 12318 5
Mg	CM69L4537100M	0.315	0.143					6 28309 12669 8
Zn	CM69L4537100Z	1.265	0.574	in	3.9	3.6		6 28309 12317 8

YAMAHA 200 - 225 - 250 - 300 HP

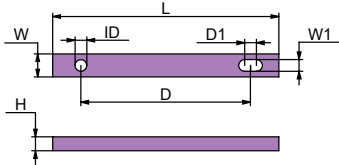

	PID	LB	KG		L	W	W1	H	D	D1	ID	UPC
Al	CM825271A	0.247	0.112	mm	193	19.05	6.35	12.7	167	8.13	6.86	6 28309 20958 2
Mg	CM825271M	0.156	0.071									6 28309 20979 7
Zn	CM825271Z	0.617	0.280	in	7.6	0.75	0.25	0.5	6.58	0.32	0.27	6 28309 20937 7

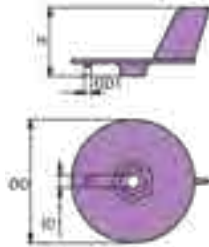

	PID	LB	KG		OD	OD1	ID	H	UPC
Al	CM82795MA	0.185	0.084	mm	95	4.9	8.5	53	6 28309 20959 9
Mg	CM82795MM	0.128	0.058						6 28309 20980 3
Zn	CM82795MZ	0.483	0.219	in	3.74	0.19	0.33	2.09	6 28309 20938 4

25-30 HP YAMAHA

Martyr®
YAMAHA™ ANODES

YAMAHA™ ANODE KITS

PLEASE NOTE: KITS IN PICTURES SHOWN IN ALUMINUM ALLOY.
SEE THE CATALOG LISTING FOR ALL ALLOYS AVAILABLE.



	PID	LB	KG	Contains	Fits	UPC
Al	CMY150KITA	1.757	0.797	CM6G54525101 X 1	Yamaha 150-200 HP Outboards	6 28309 12663 6
Mg	CMY150KITM	1.281	0.581	CM6J94537101 X 1		6 28309 15994 8



	PID	LB	KG	Contains	Fits	UPC
Al	CMY150CRKITA	1.757	0.797	CM6G54525101 X 1	Yamaha 150-200 HP Outboards (Counter Rotation)	6 28309 12664 3
Mg	CMY150CRKITM	1.289	0.585	CM6K14537102 X 1		6 28309 24697 6

YAMAHA™ ANODE KITS



	PID	LB	KG	Contains	Fits	UPC
Al	CMY200250KITA	1.777	0.806	CM6G54525101 X 1 CM61A4537100 X 1	Yamaha 200-250 HP Outboards	6 28309 12662 9
Mg	CMY200250KITM	1.283	0.582			6 28309 15995 5



	PID	LB	KG	Contains	Fits	UPC
Al	CMYHP200300KITA	1.733	0.786	CM6G54525101 X 1 CM69L4537100 X 1	Yamaha High Performance 200 - 300 HP Outboards	6 28309 12665 0
Mg	CMYHP200300KITM	1.177	0.534			6 28309 23322 8



	PID	LB	KG	Contains	Fits	UPC
Al	CMY300350KITA	1.296	0.588	CM6AW4525100 X 1 CM6AW4537300 X 1	300-350 HP Outboard	6 28309 26013 2
Mg	CMY300350KITM	0.981	0.445			6 28309 26035 4
Zn	CMY300350KITZ	2.769	1.256			6 28309 25989 1



	PID	LB	KG	Contains	Fits	UPC
Al	CMY300350XPKITA	2.16	0.98	CM6AW4561900 X 1 CM6AW4537300 X 1 CM6AW4525100 X 1	Yamaha 300- 350XP	6 28309 26014 9
Mg	CMY300350XPKITM	1.56	0.71			6 28309 26036 1
Zn	CMY300350XPKITZ	4.91	2.23			6 28309 25990 7

**NEW
PRODUCTS**

YAMAHA™ ANODES

YAMAHA MARINER™ ANODE KITS



	PID	LB	KG	Contains	Fits	UPC
Al	CMY4050KITA	1.08	0.49	CM6644537101 X 1 CM65W4525100 X 1 CM63D4525101 X 1 CM67C4525100 X 1 CM6881132500 X 1	Yamaha 40-50HP	6 28309 26015 6
Mg	CMY4050KITM	0.75	0.34			6 28309 26037 8
Zn	CMY4050KITZ	2.49	1.13			6 28309 25991 4



	PID	LB	KG	Contains	Fits	UPC
Al	CMY4060KITA	0.92	0.42	CM65W4525100 X 3 CM67C4525100 X 1 CM67C4537100 X 1	Yamaha 4T 40-60 HP	6 28309 24970 0
Mg	CMY4060KITM	0.74	0.34			6 28309 24971 7
Zn	CMY4060KITZ	1.79	0.81			6 28309 24972 4

Choose
Aluminum

Al premium
SALT AND BRACKISH WATER

Anodes for
salt and brackish
water and
Magnesium

Mg fresh
FRESH WATER ONLY
for freshwater.

YAMAHA MARINER™ ANODE KITS

	PID	LB	KG	Contains	Fits	UPC
Al	CMY6090KITA	1.16	0.52	CM6884537102 X 1 CM6H14525102 X 1	Yamaha 60-90HP	6 28309 24973 1
Mg	CMY6090KITM	0.87	0.39			6 28309 24974 8
Zn	CMY6090KITZ	2.43	1.10			6 28309 24975 5



	PID	LB	KG	Contains	Fits	UPC
Al	CMY80100KITA	1.170	0.531	CM6H14525102 X 1 CM67F4537100 X 1 CM67F1132500 X 1	Yamaha 80-100HP	6 28309 26016 3
Mg	CMY80100KITM	0.873	0.396			6 28309 26038 5
Zn	CMY80100KITZ	2.456	1.114			6 28309 25992 1

Martyn
YAMAHA™ ANODES

BENNETT TRIM TAB™ ANODES AND KITS

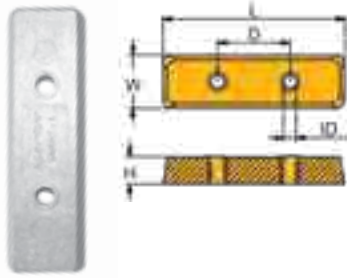

PID		LB	KG		L	W	H	D	ID	UPC
Al	CMBNT1AA	0.187	0.085	mm	96	25	15	38	6.85	6 28309 17570 2
Mg	CMBNT1AM	0.119	0.054							6 28309 24300 5
Zn	CMBNT1AZ	0.483	0.219	in	3.78	1.1	0.57	1.5	0.27	6 28309 11622 4

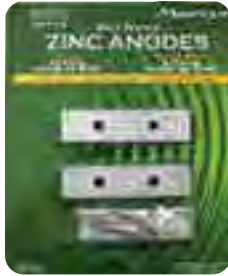

PID		LB	KG	Contains		UPC
Al	CMBNT1AKITA	0.602	0.273	CMBNT1A X 2		6 28309 24188 9
Mg	CMBNT1AKITM	0.465	0.211			6 28309 24299 2
Zn	CMBNT1AKITZ	1.192	0.541			6 28309 12474 8

DE-ICER/AERATOR ANODES

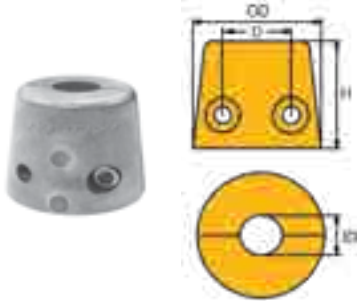

PID		LB	KG		OD	ID	D	H	UPC
Al	CMDEICERA	0.147	0.067	mm	38	13	20	32	6 28309 12856 2
Mg	CMDEICERM	0.099	0.045						6 28309 12961 3
Zn	CMDEICERZ	0.335	0.152	in	1.5	0.5	0.8	1.26	6 28309 12987 3

FRIGO-BOAT™ ANODES

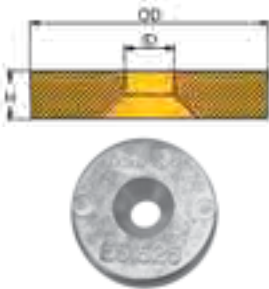

PID		LB	KG		OD	ID	H	UPC
Al	CM51525A	0.033	0.015	mm	34.5	7	7	6 28309 19595 3
Mg	CM51525M	0.022	0.010					6 28309 24278 7
Zn	CM51525Z	0.088	0.040	in	1.36	0.28	0.28	6 28309 17081 3

GROUND PLATE ANODES

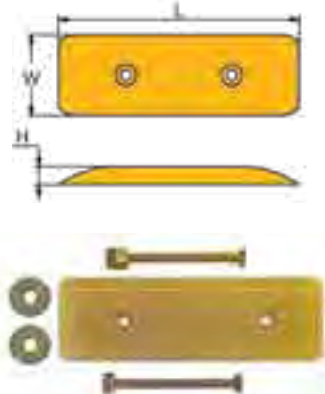

PID	LB	KG		L	W	H	Fastener	UPC
10421419	1.404	0.637	mm	152	50	12	¼ - 20	6 28309 21419 7
			in	6	1.97	0.47		
10421420	2.089	0.948	mm	203	62	12	¼ - 20	6 28309 21420 3
			in	8	2.44	0.47		
10421421	3.853	1.748	mm	304	75	12	¾ - 16	6 28309 21421 0
			in	11.97	2.95	0.47		
10421422	10.996	4.988	mm	456	151	12	¾ - 16	6 28309 21422 7
			in	18	5.94	0.47		

WASHER MATERIAL: BRONZE/GOLD-PLATED
BOLT MATERIAL: BRONZE/GOLD-PLATED
NUT MATERIAL: BRONZE/GOLD-PLATED

MISCELLANEOUS ANODES

Choose
Aluminum

Al premium
SALT AND BRACKISH WATER

Anodes for
salt and brackish
water and
Magnesium

Mg fresh
FRESH WATER ONLY
for freshwater.

LINE CUTTER ANODES

		PID	LB	KG		L	W	H	D	ID	UPC
Al	Model A	CMLCAA	0.014	0.006	mm	24	17.8	17	8	5	6 28309 24219 0
Mg		CMLCAM	0.009	0.0045		in	0.9	0.7	0.67	0.3	0.2
Zn		CMLCAZ	0.031	0.014	in	0.9	0.7	0.67	0.3	0.2	6 28309 17085 1
Al	Model B	CMLCBA	0.014	0.006	mm	24	17.8	17	8	5	6 28309 24220 6
Mg		CMLCBM	0.009	0.0044		in	0.9	0.7	0.67	0.3	0.2
Zn		CMLCBZ	0.031	0.014	in	0.9	0.7	0.67	0.3	0.2	6 28309 17086 8
Al	Model C,D,E	CMLCCDEA	0.038	0.017	mm	30	25.8	31	13	5.2	6 28309 24221 3
Mg		CMLCCDEM	0.026	0.012		in	1.2	1.01	1.2	0.5	0.2
Zn		CMLCCDEZ	0.092	0.042	in	1.2	1.01	1.2	0.5	0.2	6 28309 17087 5
Al	Model F1	CMLCF1A	0.094	0.043	mm	49	25.8	44	25	5	6 28309 24222 0
Mg		CMLCF1M	0.061	0.028		in	1.93	1.01	1.73	1	0.2
Zn		CMLCF1Z	0.240	0.109	in	1.93	1.01	1.73	1	0.2	6 28309 17478 1

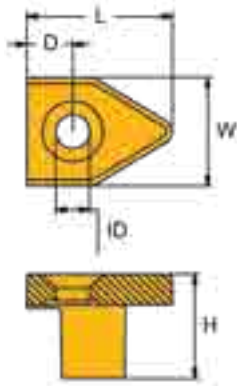

SEA STRAINER ANODES

		PID	LB	KG		L	W	H	D	ID	UPC
Al	Model F1	CMSZ1A	0.236	0.107	mm	97	38	14	38	8.3	6 28309 17574 0
Mg		CMSZ1M	0.145	0.066		in	3.8	1.5	0.5	1.5	0.32
Zn		CMSZ1Z	0.584	0.265	in	3.8	1.5	0.5	1.5	0.32	6 28309 17094 3

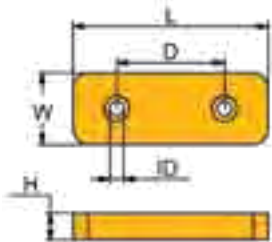
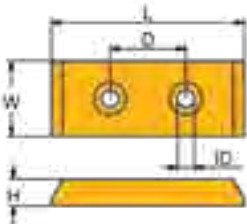

		PID	LB	KG		L	W	H	D	ID	UPC
Al	Model F1	CM656934A (DOKA)	0.149	0.068	mm	83	31	11	46	6	6 28309 11551 7
Mg		CM656934M (DOKA)	0.092	0.042		in	3.25	1.20	0.45	1.80	0.23
Zn		CM656934Z (DOKA)	0.374	0.170	in	3.25	1.20	0.45	1.80	0.23	6 28309 11306 3



Martyr
MISCELLANEOUS ANODES

TWIN DISC™ ANODES



PID		LB	KG		L	W	H	D	ID	UPC
Al	ARNSMALLA	0.551	0.250	mm	156	32	30.73	89	8	6 28309 12343 7
Mg	ARNSMALLM	0.366	0.166							6 28309 17599 3
Zn	ARNSMALL	1.327	0.602	in	6.13	1.25	1.21	3.50	0.30	6 28309 11376 6
Al	ARNLARGEA	1.505	0.683	mm	188	45.72	46.48	127	10	6 28309 12342 0
Mg	ARNLARGE M	0.992	0.450							6 28309 17598 6
Zn	ARNLARGE	3.754	1.703	in	7.40	1.80	1.83	5.00	0.40	6 28309 11377 3

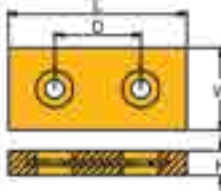

PID		LB	KG		L	W	H	D	UPC
Al	CMFL465A	1.192	0.541	mm	145	67	20	70	6 28309 23655 7
Mg	CMFL465M	0.879	0.399						6 28309 23656 4
Zn	CMFL465Z	2.570	1.166	in	5.71	2.64	0.79	2.76	6 28309 23657 1

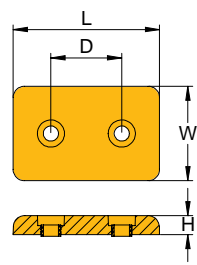

PID		LB	KG		L	W	D	H	UPC
Al	CMAR580A	1.658	0.752	mm	155	100	75	20	6 28309 23547 5
Mg	CMAR580M	1.071	0.486						6 28309 23548 2
Zn	CMAR580Z	4.228	1.918	in	6.10	3.94	2.95	0.79	6 28309 23549 9

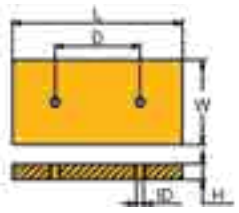

PID		LB	KG		L	W	D	ID	H	UPC
Al	CMAR670A	7.262	3.294	mm	300	150	125	12.95	28	6 28309 23550 5
Mg	CMAR670M	4.643	2.106							6 28309 23551 2
Zn	CMAR670Z	18.759	8.509	in	11.81	5.91	4.92	0.51	1.10	6 28309 23552 9

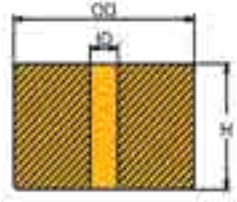

PID		LB	KG		OD	H	ID	UPC
Zn	CMAR671Z	2.09	0.95	mm	65	43	10	6 28309 23555 0
				in	2.56	1.69	0.39	

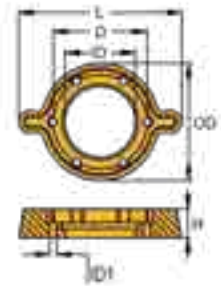

PID		LB	KG		L	H	D	OD	ID	ID1	UPC
Al	CMAR672A	0.491	0.223	mm	139	24	80	100	60	7	6 28309 23556 7
Mg	CMAR672M	0.311	0.141								6 28309 23557 4
Zn	CMAR672Z	1.281	0.581	in	5.12	0.94	3.15	3.94	2.36	0.28	6 28309 23558 1

TECHNODRIVE SP60 SAILDRIVE

MISCELLANEOUS ANODES

Protect your boat, respect our waters.

ENGINE COOLING SYSTEM ANODES with plug



Martyr®
ENGINE COOLING SYSTEM ANODES

	PID	LB	KG		L	OD	THD	UPC
Zn	CME00	0.042	0.019	mm	52	6.4	1/8 NPT	6 28309 10319 4
				in	2.06	1/4		
Zn	CME0	0.095	0.043	mm	45	9.5	1/4 NPT	6 28309 10318 7
				in	1¾	3/8		
Zn	CME1	0.165	0.075	mm	51	12.7	3/8 NPT	6 28309 10320 0
				in	2	1/2		
Zn	CME1D	0.154	0.070	mm	45	12.7	3/8 NPT	6 28309 10321 7
				in	1¾	1/2		
Zn	CME1E	0.143	0.065	mm	38	12.7	3/8 NPT	6 28309 10322 4
				in	1½	1/2		
Zn	CME1F	0.130	0.059	mm	32	12.7	3/8 NPT	6 28309 10323 1
				in	1¼	1/2		
Zn	CME1G	0.117	0.053	mm	25	12.7	3/8 NPT	6 28309 10324 8
				in	1	1/2		
Zn	CME1H	0.123	0.056	mm	51	9.5	3/8 NPT	6 28309 10325 5
				in	2	3/8		
Zn	CME2	0.279	0.127	mm	51	16	1/2 NPT	6 28309 10326 2
				in	2	5/8		
Zn	CME2S	0.220	0.100	mm	38.1	16	1/2 NPT	6 28309 10327 9
				in	1 1/2	5/8		
Zn	CME3	0.440	0.200	mm	51	19	3/4 NPT	6 28309 10328 6
				in	2	3/4		
Zn	CME3S	0.330	0.150	mm	19	19	3/4 NPT	6 28309 11326 1
				in	3/4	3/4		
Zn	CME4	0.609	0.277	mm	86	19	3/4 NPT	6 28309 10329 3
				in	3 3/8	3/4		
Zn	CME5	0.638	0.290	mm	92	19	3/4 NPT	6 28309 10330 9
				in	3 5/8	3/4		
Zn	CME2BSP	0.279	0.127	mm	51	16	1/2 BSPT	6 28309 12176 1
				in	2	5/8		
Zn	CME3BSP	0.453	0.206	mm	51	19	3/4 BSPT	6 28309 12177 8
				in	2	3/4		
Zn	CME0AZ	0.125	0.057	mm	63	9.5	1/4 NPT	6 28309 17459 0
				in	2 ½	3/8		
Zn	CME2BZ	0.356	0.162	mm	76	16	1/2 NPT	6 28309 17460 6
				in	3	5/8		

ENGINE COOLING SYSTEM BRASS PLUGS replacement



BRASS PLUG REPLACEMENT

	PID	LB	KG	THD	THD1	UPC
Plug	CMEP00	0.016	0.007	1/8 NPT	1/4 UNC	6 28309 15844 6
Plug	CMEP0	0.050	0.023	1/4 NPT	5/16 UNC	6 28309 15843 9
Plug	CMEP1	0.060	0.027	3/8 NPT	3/8 UNC	6 28309 15846 0
Plug	CMEP2	0.120	0.054	1/2 NPT	7/16 UNC	6 28309 15847 7
Plug	CMEP3	0.250	0.113	3/4 NPT	1/2 UNC	6 28309 15849 1
Plug	CMEP2BSP	0.140	0.063	1/2 BSPT	7/16 UNC	6 28309 15848 4
Plug	CMEP3BSP	0.240	0.109	3/4 BSPT	1/2 UNC	6 28309 15850 7

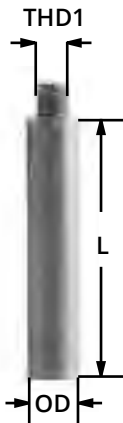

ANODE REPLACEMENT

ENGINE COOLING SYSTEM ANODES replacement

	PID	LB	KG		L	OD	THD1	UPC
Zn	CMEZ00	0.026	0.012	mm	52	6.4	1/4 UNC	6 28309 10338 5
				in	2.06	1/4		
Zn	CMEZ0	0.053	0.024	mm	45	9.5	5/16 UNC	6 28309 10337 8
				in	1¾	3/8		
Zn	CMEZ1	0.103	0.047	mm	51	12.7	3/8 UNC	6 28309 10339 2
				in	2	1/2		
Zn	CMEZ1D	0.095	0.043	mm	45	12.7	3/8 UNC	6 28309 10340 8
				in	1¾	1/2		
Zn	CMEZ1E	0.084	0.038	mm	38	12.7	3/8 UNC	6 28309 10341 5
				in	1½	1/2		
Zn	CMEZ1F	0.070	0.032	mm	32	12.7	3/8 UNC	6 28309 10342 2
				in	1¼	1/2		
Zn	CMEZ1G	0.059	0.027	mm	25	9.5	3/8 UNC	6 28309 10343 9
				in	1	1/2		
Zn	CMEZ1H	0.062	0.028	mm	51	10	3/8 UNC	6 28309 10344 6
				in	2	3/8		
Zn	CMEZ2	0.165	0.075	mm	51	16	7/16 UNC	6 28309 10345 3
				in	2	5/8		
Zn	CMEZ2S	0.127	0.058	mm	38	16	7/16 UNC	6 28309 10346 0
				in	1½	5/8		
Zn	CMEZ3	0.231	0.105	mm	51	19	1/2 UNC	6 28309 10347 7
				in	2	3/4		
Zn	CMEZ3S	0.101	0.046	mm	19	19	1/2 UNC	6 28309 12233 1
				in	3/4	3/4		
Zn	CMEZ4	0.381	0.173	mm	86	19	1/2 UNC	6 28309 10348 4
				in	3 ⅜	3/4		
Zn	CMEZ5	0.409	0.186	mm	92	19	1/2 UNC	6 28309 10349 1
				in	3 ⅝	3/4		
Zn	CMEZ0AZ	0.079	0.036	mm	63.5	9.52	5/16 UNC	6 28309 18243 4
				in	2 1/2	3/8		
Zn	CMEZ2BZ	0.238	0.108	mm	76.2	16	7/16 UNC	6 28309 18244 1
				in	3	5/8		

Choose
Aluminum

Al premium
SALT AND BRACKISH WATER

Anodes for
salt and brackish
water and
Magnesium

Mg fresh
FRESH WATER ONLY
for freshwater.

Martyr

ENGINE COOLING SYSTEM ANODES

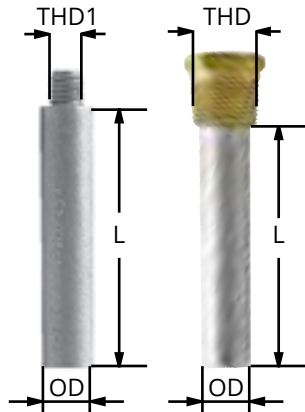
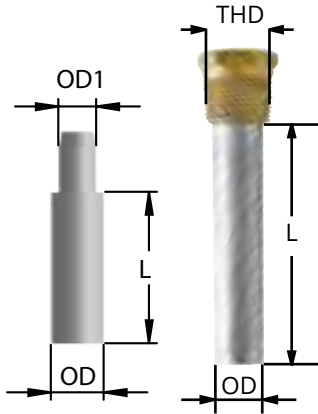

ENGINE COOLING SYSTEM ANODES with plug/ anodes replacement/brass plug

ENGINE	PID	LB	KG		L	OD	THD	OD1	UPC
Zn	AIFO	CM8105277Z	0.059	0.027	mm in	26 1.02	13 0.51	-- Ø10 0.39	6 28309 23487 4
Zn	AIFO	CM8105277PZ	0.143	0.065	mm in	26 1.02	13 0.51	M18 x1.5 --	6 28309 23486 7
Plug	AIFO	CMEBP1018	0.083	0.038	mm in	-- --	-- --	M18 x1.5 Ø10 0.39	6 28309 23887 2
Zn	AIFO	CM8101772Z	0.119	0.054	mm in	20 0.79	20 0.79	-- Ø14 0.55	6 28309 23481 2
Zn	AIFO	CM8101772PZ	0.350	0.159	mm in	20 0.79	20 0.79	M28 x1.5 --	6 28309 23480 5
Plug	AIFO	CMEBP1428	0.229	0.104	mm in	-- --	-- --	M28 x1.5" Ø14 0.55	6 28309 23889 6
Zn	AIFO	CMAF920Z	0.021	0.0097	mm in	20 0.79	9 0.35	-- Ø4.5 0.18	6 28309 23543 7
Zn	AIFO	CMAF920PZ	0.079	0.036	mm in	20 0.79	9 0.35	M12 x1.5 --	6 28309 23542 0
Plug	AIFO	CMEBP4512	0.059	0.027	mm in	-- --	-- --	M12 x1.5 Ø4.5 0.18	6 28309 23892 6
Zn	AIFO	CM8109743Z	0.027	0.0124	mm in	18 0.71	10 0.39	-- Ø7 0.28	6 28309 23493 5
Zn	AIFO	CM8109743PZ	0.066	0.030	mm in	18 0.71	10 0.39	M12 x1.5 --	6 28309 23492 8
Plug	AIFO	CMEBP712	0.039	0.018	mm in	-- --	-- --	M12 x1.5 Ø7 0.28	6 28309 24428 6
Zn	AIFO	CMAF720Z	0.014	0.0064	mm in	20 0.79	7 0.28	-- Ø5 0.20	6 28309 23537 6
Zn	AIFO	CMEAF720PZ	0.046	0.021	mm in	20 0.79	7 0.28	M10 x1.25 --	6 28309 23621 2
Plug	AIFO	CMEBP510	0.033	0.015	mm in	-- --	-- --	M10 x1.25 Ø5 0.20	6 28309 24427 9

ENGINE	PID	LB	KG		L	OD	THD	THD1	UPC
Zn	BAUDOUIIN	CMEBD20Z	0.225	0.102	mm in	45 1.77	20 0.79	-- M8 x1.25	6 28309 21477 7
Zn	BAUDOUIIN	CMEBD20PZ	0.401	0.182	mm in	45 1.77	20 0.79	M24 x1.5 --	6 28309 21476 0
Plug	BAUDOUIIN	CMEBP824	0.176	0.080	mm in	-- --	-- --	M24 x1.5 M8 x1.25	6 28309 23253 5
Zn	BUKH	CMB00E0450	0.066	0.030	mm in	36 1.42	12 0.47	-- M5 x0.8	6 28309 23561 1

ENGINE COOLING SYSTEM ANODES

with plug/ anodes replacement/brass plug

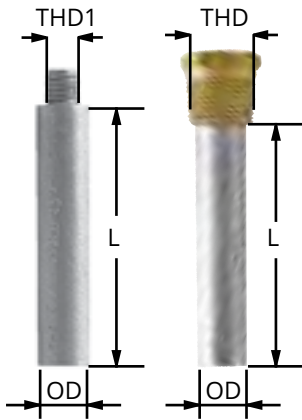

ENGINE	PID	LB	KG		L	OD	THD	THD1	UPC	
Zn	CATERPILLAR	CM8515850Z	0.430	0.195	mm	85.85	19.05	--	5/8 BSW	6 28309 12174 7
					in	3.38	0.75			
Zn	CATERPILLAR	CM6L2288Z	0.209	0.095	mm	63.5	15.75	--	3/8 BSW	6 28309 12179 2
					in	2.50	0.62			
Zn	CATERPILLAR	CM6L2288PZ (2284 SERIES)	0.343	0.155	mm	63.5	15.75	1/2 NPT	--	6 28309 24110 0
					in	2.50	0.62			
Zn	CATERPILLAR	CM6L2289Z	0.242	0.110	mm	76	16	--	3/8 BSW	6 28309 23454 6
					in	2.99	0.63			
Zn	CATERPILLAR	CM6L2289PZ (2289 SERIES)	0.372	0.169	mm	76	16	1/2 NPT	--	6 28309 23453 9
					in	2.99	0.63			
Plug	CATERPILLAR	CMEBP3812	0.134	0.060	mm	--	--	1/2 NPT	3/8 BSW	6 28309 24425 5
					in	--	--			
Zn	CATERPILLAR	CM6L2283Z	0.069	0.031	mm	58.42	9.39	--	1/4 BSW	6 28309 12167 9
					in	2.30	0.37			
Zn	CATERPILLAR	CM6L2283PZ	0.119	0.054	mm	58.42	9.39	1/4 NPT	--	6 28309 24109 4
					in	2.30	0.37			
Zn	CATERPILLAR	CM6L3104Z	0.048	0.022	mm	38	10	--	1/4 UNC	6 28309 23457 7
					in	1.50	0.39			
Zn	CATERPILLAR	CM6L3104PZ	0.097	0.044	mm	38	10	1/4 NPT	--	6 28309 27271 5
					in	1.50	0.39			
Plug	CATERPILLAR	CMEBP1414	0.050	0.022	mm	--	--	1/4 NPT	1/4 BSW	6 28309 24424 8
					in	--	--			
Zn	CATERPILLAR	CM6L2016Z	0.159	0.072	mm	20.00	22.00	--	5/8 UNF	6 28309 12339 0
					in	0.80	0.87			
Zn	CATERPILLAR	CM6L2016PZ	0.369	0.167	mm	20.00	22.00	3/4 NPT	--	6 28309 24108 7
					in	0.80	0.87			
Plug	CATERPILLAR	CMEBP5834	0.210	0.095	mm	--	--	3/4 NPT	5/8 UNF	6 28309 23895 7
					in	--	--			
Zn	CATERPILLAR	CM6L2285Z	0.732	0.332	mm	54	32	--	3/4 BSW	6 28309 23448 5
					in	2.13	1.26			
Zn	CATERPILLAR	CM6L2284Z (2284 SERIES)	0.086	0.039	mm	33	14	--	5/16 UNC	6 28309 23445 4
					in	1.30	0.55			
Zn	CATERPILLAR	CM6L2280GZ	0.083	0.038	mm	38	12	--	7/16 UNF	6 28309 24097 4
					in	1.50	0.47			
Zn	CATERPILLAR	CM6L2280GPZ	0.154	0.070	mm	38	12	3/8 BSPT	--	6 28309 24096 7
					in	1.50	0.47			
Plug	CATERPILLAR	CMEBP71638	0.068	0.031	mm	--	--	3/8 BSPT	7/16 UNF	6 28309 24429 3
					in	--	--			
Zn	CATERPILLAR	CMCA1230Z	0.061	0.028	mm	30	12	--	3/8 BSW	6 28309 23594 9
					in	1.18	0.47			
Zn	CATERPILLAR	CM6L2280PZ	0.093	0.042	mm	41	12	--	3/8 BSW	6 28309 23442 3
					in	1.61	0.47			

ENGINE COOLING SYSTEM ANODES

ENGINE COOLING SYSTEM ANODES

with plug/ anodes replacement/brass plug

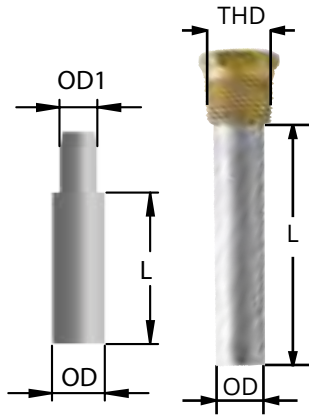
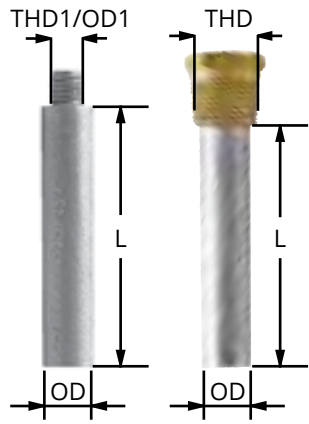

ENGINE	PID	LB	KG		L	OD	THD	THD1 / OD1	UPC	
Zn	CUMMINS	CMCU1650Z	0.169	0.077	mm in	50 1.97	16 0.63	--	Ø12 0.47	6 28309 23615 1
Zn	CUMMINS	CMCU1650PZ	0.279	0.127	mm in	50 1.97	16 0.63	1/2 NPT	--	6 28309 23614 4
Plug	CUMMINS	CMEBP1212	0.110	0.050	mm in	--	--	1/2 NPT	Ø12 0.47	6 28309 23888 9
Zn	CUMMINS	CMECU16Z	0.167	0.076	mm in	50 1.97	16 0.63	--	7/16 UNF	6 28309 21483 8
Zn	CUMMINS	CMECU16PZ	0.277	0.126	mm in	50 1.97	16 0.63	1/2 NPT	--	6 28309 21482 1
Plug	CUMMINS	CMEBP71612	0.110	0.050	mm in	--	--	1/2 NPT	7/16 UNF	6 28309 23252 8
Zn	CUMMINS	CMCU1020Z	0.026	0.012	mm in	20 0.79	10 0.39	--	M6	6 28309 23606 9
Zn	CUMMINS	CMCU1020PZ	0.094	0.043	mm in	20 0.79	10 0.39	3/8 GAS	--	6 28309 23605 2
Plug	CUMMINS	CMEBP638	0.068	0.031	mm in	--	--	3/8 GAS	M6	6 28309 23896 4
Zn	CUMMINS	CMCU1865Z	0.295	0.134	mm in	65 2.56	18 0.71	--	M16X 1.5	6 28309 23618 2
Zn	CUMMINS	CMCU1645Z	0.147	0.067	mm in	45 1.77	16 0.63	--	3/8 BSW	6 28309 23609 0

ENGINE	PID	LB	KG		L	OD	THD	OD1	UPC	
Zn	FORD	CMFO1018Z	0.028	0.013	mm in	18 0.71	10 0.39	--	Ø8.5 0.33	6 28309 23663 2
Zn	FORD	CMFO1018PZ	0.061	0.028	mm in	18 0.71	10 0.39	1/4 NPT	--	6 28309 23662 5
Plug	FORD	CMEBP8514	0.035	0.016	mm in	--	--	1/4 NPT	Ø8.5 0.33	6 28309 23900 8
Zn	FORD	CMFO1332Z	0.072	0.033	mm in	32 1.26	13 0.51	--	Ø9 0.35	6 28309 23666 3

ENGINE	PID	LB	KG		L	OD	THD	THD1	UPC	
Zn	GENERAL MOTORS	CM8517479Z	0.136	0.062	mm in	40 1.57	16 0.63	--	7/16 BSW	6 28309 23513 0
Zn	GENERAL MOTORS	CM8517479PZ	0.264	0.120	mm in	40 1.57	16 0.63	1/2 NPT	--	6 28309 23512 3
Plug	GENERAL MOTORS	CMEBP716B12	0.128	0.058	mm in	--	--	1/2 NPT	7/16 BSW	Please contact us
Zn	GENERAL MOTORS	CMEZ2	0.165	0.075	mm in	51 2	16 0.63	--	7/16 UNC	6 28309 10345 3
Zn	GENERAL MOTORS	CM8517480BSZ	0.280	0.127	mm in	51 2	16 0.63	1/2 BSPT	--	6 28309 22974 0
Plug	GENERAL MOTORS	CMEBP71612L	0.110	0.049	mm in	--	--	1/2 BSPT	7/16 UNC	Please contact us
Zn	GENERAL MOTORS	CMEZ2S	0.127	0.058	mm in	38 1.50	16 0.63	--	7/16 UNC	6 28309 10346 0
Zn	GENERAL MOTORS	CM8517479BSZ	0.220	0.099	mm in	38 1.50	16 0.63	1/2 NPT	--	6 28309 22973 3
Plug	GENERAL MOTORS	CMEBP71612	0.090	0.041	mm in	--	--	1/2 NPT	7/16 UNF	6 28309 23252 8
Zn	GENERAL MOTORS	CMEZ4SL	0.440	0.199	mm in	89 3.50	19 0.75	--	5/8 UNC	6 28309 12116 7
Zn	GENERAL MOTORS	CM8515842BSZ	0.660	0.299	mm in	89 3.50	19 0.75	3/4 BSPT	--	6 28309 22972 6
Plug	GENERAL MOTORS	CMEP5834	0.220	0.099	mm in	--	--	3/4 BSPT	5/8 UNC	6 28309 22979 5
Zn	GENERAL MOTORS	CM8515850Z	0.430	0.195	mm in	86 3.38	19 0.75	--	5/8 BSW	6 28309 12174 7
Zn	GENERAL MOTORS	CM8515851Z	0.386	0.175	mm in	80 3.15	20 0.79	--	5/8 BSW	6 28309 23507 9
Zn	GENERAL MOTORS	CM8515842Z	0.280	0.127	mm in	54 2.12	19 0.75	--	5/8 BSW	6 28309 12175 4
Zn	GENERAL MOTORS	CM8925832Z	0.077	0.035	mm in	40 1.57	12 0.47	--	3/8 BSW	6 28309 23522 2

ENGINE COOLING SYSTEM ANODES

with plug/ anodes replacement/brass plug

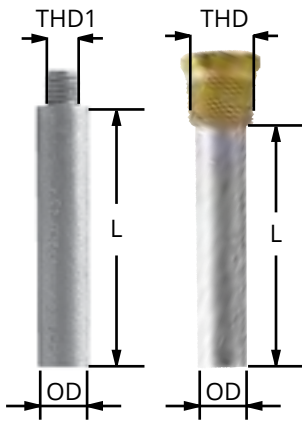

ENGINE	PID		L	OD	THD	THD1	UPC	
Zn	ISOTTA FRASCHINI	CMIF2034Z	mm	34	20	--	M18 x1.5	6 28309 23672 4
			in	1.34	0.79			
Zn	ISOTTA FRASCHINI	CMIF2034PZ	mm	34	20	M24 x1.5	--	6 28309 23671 7
			in	1.34	0.79			

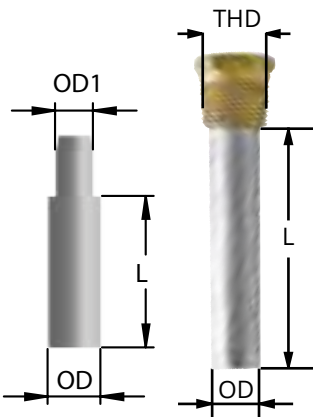

ENGINE	PID	LB	KG		L	OD	THD	OD1	UPC	
Zn	NANNI	CM970494635Z	0.031	0.014	mm	20	10	--	Ø8	6 28309 23531 4
					in	0.79	0.39			
Zn	NANNI	CM970494635PZ	0.088	0.040	mm	20	10	M16 x1.5	--	6 28309 23530 7
					in	0.79	0.39			
Plug	NANNI	CMEBP816	0.057	0.026	mm	--	--	M16 x1.5	Ø8	6 28309 23898 8
					in	--	--			
Zn	NANNI	CMNN2525Z	0.247	0.112	mm	25	25	--	Ø22	6 28309 23758 5
					in	0.98	0.98			
Zn	NANNI	CMNN2525PZ	0.483	0.219	mm	25	25	M30 x1.5	--	6 28309 23757 8
					in	0.98	0.98			
Plug	NANNI	CMEBP2230	0.236	0.107	mm	--	--	M30 x1.5	Ø22	6 28309 23891 9
					in	--	--			

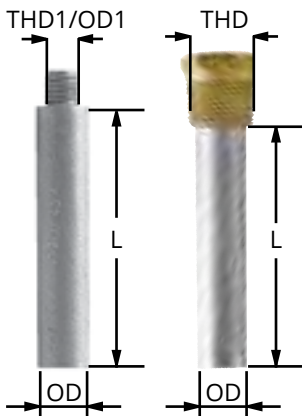

ENGINE	PID	LB	KG		L	OD	THD	THD1/ OD1	UPC	
Zn	ONAN	CMON1030Z	0.039	0.018	mm	30	10	--	Ø8	6 28309 23761 5
					in	1.18	0.39			
Zn	ONAN	CM1301341PZ	0.099	0.045	mm	30	10	3/8 NPT	--	6 28309 23330 3
					in	1.18	0.39			
Plug	ONAN	CMEBPD838	0.059	0.027	mm	--	--	3/8 NPT	Ø8	6 28309 27107 7
					in	--	--			
Zn	ONAN	CMON1131Z	0.050	0.023	mm	31	11	--	M8	6 28309 23767 7
					in	1.22	0.43			
Zn	ONAN	CMON1131PZ	0.1146	0.052	mm	31	11	3/8 NPT	--	6 28309 23766 0
					in	1.22	0.43			
Plug	ONAN	CMEBP838	0.064	0.029	mm	--	--	3/8 NPT	M8	6 28309 23899 5
					in	--	--			
Zn	ONAN	CMON1326Z	0.064	0.029	mm	26	13	--	Ø9.5	6 28309 23770 7
					in	1.02	0.51			

Choose
Aluminum

Al premium
SALT AND BRACKISH WATER

Anodes for
salt and brackish
water and
Magnesium

Mg fresh
FRESH WATER ONLY

for freshwater.

ENGINE COOLING SYSTEM ANODES with plug/ anodes replacement/brass plug

ENGINE	PID	LB	KG		L	OD	THD	OD1	UPC	
Zn	RENAULT	CMERE14Z	0.075	0.034	mm	25	14	--	Ø12	6 28309 21142 4
					in	0.94	0.55		0.47	
Zn	RENAULT	CMERE14PZ	0.158	0.072	mm	25	14	M18 x1.5	--	6 28309 21141 7
					in	0.94	0.55			
Plug	RENAULT	CMEREBP18	0.083	0.038	mm	--	--	M18 x1.5	Ø12	6 28309 23254 2
					in	--	--		0.47	

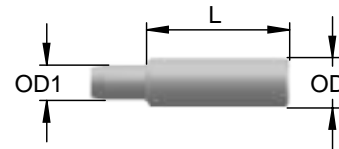
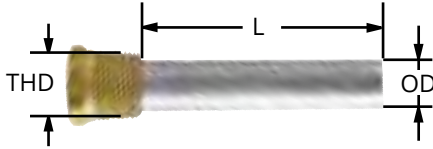

ENGINE	PID	LB	KG		L	L1	OD	OD1	UPC	
Zn	SEASALL	CMHS1760Z	0.231	0.105	mm	70	10	17	14	6 28309 25565 7
					in	2.75	0.39	0.67	0.55	

ANODE ONLY



ENGINE	PID	LB	KG		L	OD	UPC	
Zn	SEASALL	CMHS1760PZ	0.349	0.159	mm	83	17	6 28309 25564 0
					in	3.27	0.67	

W/PLUG

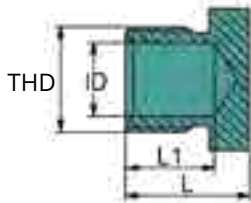

ENGINE	PID	LB	KG		ID	THD	L	L1	UPC	
Plug	SEASALL	CMEPHS1420	0.118	0.054	mm	14	M20	23	16.5	6 28309 25566 4
					in	0.55	X1.5	0.90	0.65	

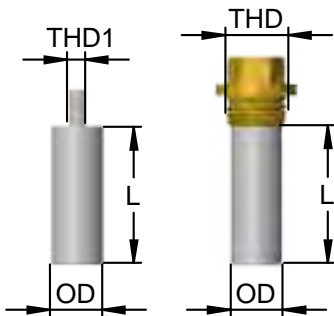

ENGINE	PID	LB	KG		L	OD	THD	THD1	UPC	
Zn	SCANIA	CMSC1763Z	0.225	0.102	mm	63	17	--	M6	6 28309 25987 7
					in	2.48	0.67			
Zn	SCANIA	CMSC1663PZ	0.359	0.163	mm	63	17	1/2 BSPP	--	6 28309 25986 0
					in	2.48	0.67			
Zn	SCANIA	CM1331818Z	0.172	0.078	mm	46	17	--	M6	6 28309 25971 6
					in	1.81	0.67			
Zn	SCANIA	CM1331818PZ	0.306	0.139	mm	46	17	1/2 BSPP	--	6 28309 25970 9
					in	1.81	0.67			
Plug	SCANIA	CMEBP612	0.134	0.061	mm	--	--	1/2 BSPP	M6	6 28309 26039 2
					in	--	--			
Zn	SCANIA	CMSC1645Z	0.152	0.069	mm	45	16	--	M12 x1.0	6 28309 23812 4
					in	1.77	0.63			

Martyr®

ENGINE COOLING SYSTEM ANODES

ENGINE COOLING SYSTEM ANODES

with plug/ anodes replacement/brass plug

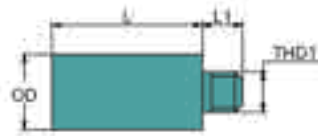

ENGINE	PID	LB	KG		L	L1	OD	THD1	UPC	
Zn	STEYR	STE217841Z	0.084	0.038	mm	30	8	15	M8	6 28309 22975 7
					in	1.18	0.31	0.59		

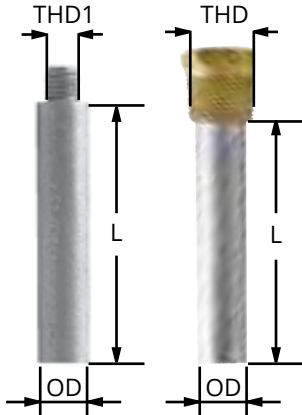

ENGINE	PID	LB	KG		L	OD	THD	THD1	UPC	
Zn	VM	CMVM40Z	0.097	0.044	mm	40	14	--	M8	6 28309 21514 9
					in	1.57	0.55			
Zn	VM	CMVM40PZ	0.183	0.083	mm	40	14	M18 x1.5	--	6 28309 21513 2
					in	1.57	0.55			
Zn	VM	CMVM20Z	0.053	0.024	mm	20	14	--	M8	6 28309 21508 8
					in	0.79	0.55			
Zn	VM	CMVM20PZ	0.139	0.063	mm	20	14	M18 x1.5	--	6 28309 21507 1
					in	0.79	0.55			
Plug	VM	CMVMBP8	0.086	0.039	mm	--	--	M18 x1.5	M8	6 28309 23261 0
					in	--	--			
Zn	VM	CMVMM10Z	0.055	0.025	mm	20	14	--	M10	6 28309 21520 0
					in	0.79	0.55			
Zn	VM	CMVMM10PZ	0.136	0.062	mm	20	14	M18 x1.5	--	6 28309 21519 4
					in	0.79	0.55			
Plug	VM	CMVMBP10	0.081	0.037	mm	--	--	M18 x1.5	M10	6 28309 23260 3
					in	--	--			



ENGINE	PID	LB	KG		L	OD	THD1	UPC	
Zn	VOLVO PENTA	CM8517479Z	0.136	0.062	mm	40	16	7/16 BSW	6 28309 23513 0
					in	1.57	0.63		
Al	VOLVO PENTA	CM838929A	0.025	0.011	mm	30	17	7/16 UNC	6 28309 12328 4
Mg	VOLVO PENTA	CM838929M	0.090	0.041				7/16 UNC	6 28309 19298 3
Zn	VOLVO PENTA	CM838929Z	0.040	0.018	in	1.18	0.67	7/16 UNC	6 28309 10128 2
								UNC	6 28309 10128 2
Zn	VOLVO PENTA	CMEZ2S	0.128	0.058	mm	38	16	7/16 UNC	6 28309 10346 0
					in	1.50	0.63		
Al	VOLVO PENTA	CM823661A	0.145	0.066	mm	43	26	3/8 UNC	6 28309 12327 7
Mg	VOLVO PENTA	CM823661M	0.106	0.048				3/8 UNC	6 28309 12374 1
Zn	VOLVO PENTA	CM823661Z	0.308	0.140	in	1.69	1.02	3/8 UNC	6 28309 10118 3
								UNC	6 28309 10118 3
Zn	VOLVO PENTA	CMVP16520Z	0.070	0.032	mm	20	16.5	5/16 BSW	6 28309 23815 5
					in	0.79	0.65		

ENGINE COOLING SYSTEM ANODES

ENGINE COOLING SYSTEM ANODES

with plug/ anodes replacement/brass plug

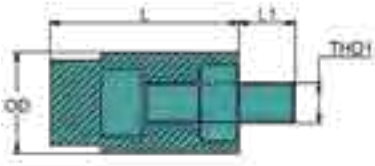

ENGINE	PID	LB	KG		L	L1	OD	THD1	UPC	
Zn	YANMAR	CM27210200370Z	0.036	0.08	mm	37	11	20	M8	6 28309 23048 7
					in	1.46	0.43	0.79		
Zn	YANMAR	CM27210200550Z	0.054	0.119	mm	55	11	20	M8	6 28309 23049 4
					in	2.17	0.43	0.79		

Martyr®

ENGINE COOLING SYSTEM ANODES



CERTIFICATE OF REGISTRATION

This is to certify that

Canada Metal (Pacific) Ltd.

7733 Progress Way, Delta, British Columbia V4G1A3 Canada

operates a

Quality Management System

which complies with the requirements of

ISO 9001:2015

for the following scope of certification

The registration covers the Quality Management System for nonferrous alloys / casting fabrication, general CNC / manual machining. Design, assembly and distribution of marine and construction related products.

Certificate No.: CERT-0115123
File No.: 802196
Issue Date: March 1, 2018

Original Certification Date: June 14, 1999
Certification Effective Date: March 1, 2018
Certificate Expiry Date: February 28, 2021

Nicole Grantham
General Manager SAI Global Certification Services



ISO 9001



Registered by:
QMI-SAI Canada Limited (SAI Global), 20 Carlson Court, Suite 200, Toronto, Ontario M9W 7K6 Canada. This registration is subject to the SAI Global Terms and Conditions for Certification. While all due care and skill was exercised in carrying out this assessment, SAI Global accepts responsibility only for proven negligence. This certificate remains the property of SAI Global and must be returned to them upon request.
To verify that this certificate is current, please refer to the SAI Global On-Line Certification Register: www.qmi-saiglobal.com/qmi_companies/



Protect your boat, respect our waters.

OUTBOARDS

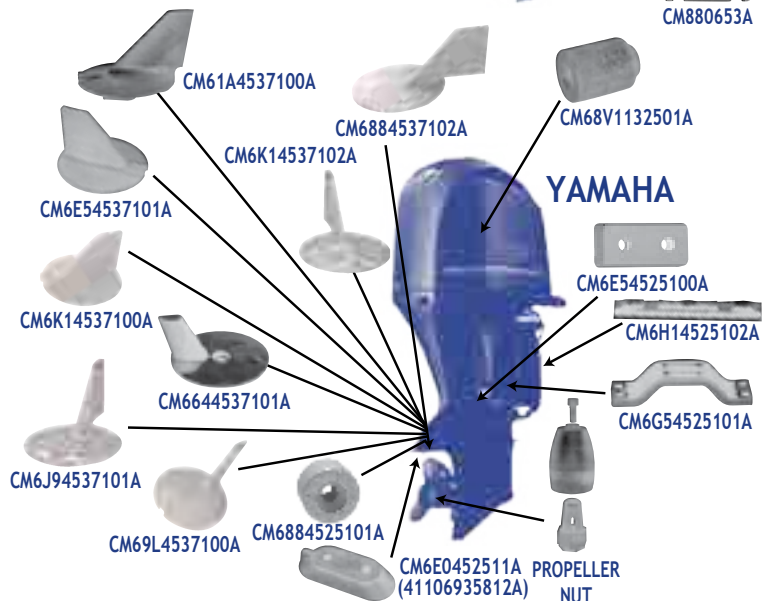
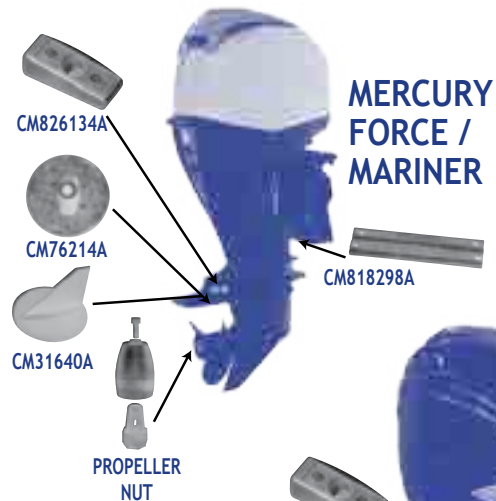
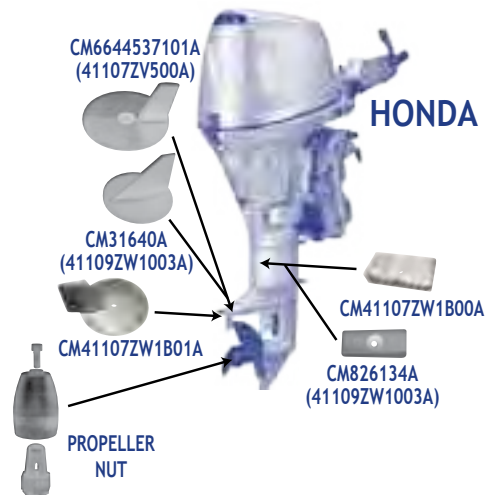

Martyr® is a registered trademark of Canada Metal (Pacific) Limited. Martyr® Anodes are manufactured under an ISO-9000 series Quality Assurance Program to original equipment standards and are guaranteed to conform to the latest US Mil-DTL-24779C(SH) specification for Aluminum anodes.

Check anodes regularly and replace them when they are 70% consumed.

Protects longer and is more efficient than Zinc.
 Protect your investment in salt and brackish water with genuine Martyr® Anodes because...
 Not all "Zincs" are created equal.



STERN DRIVES

MERCURISER

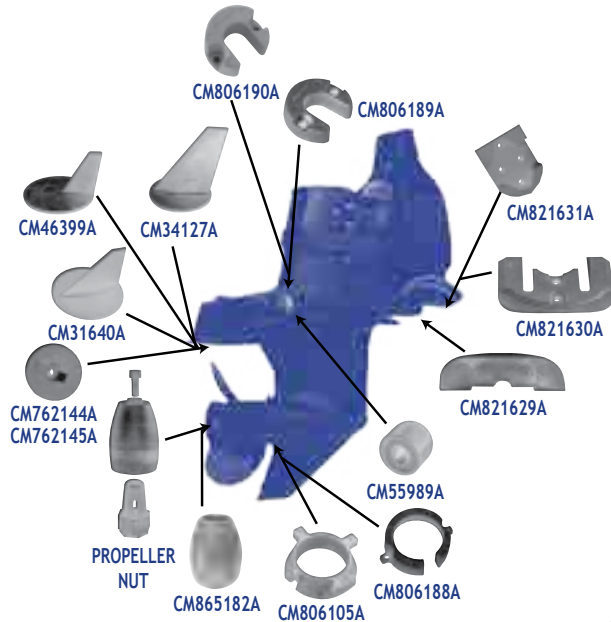

(BRP) OMC

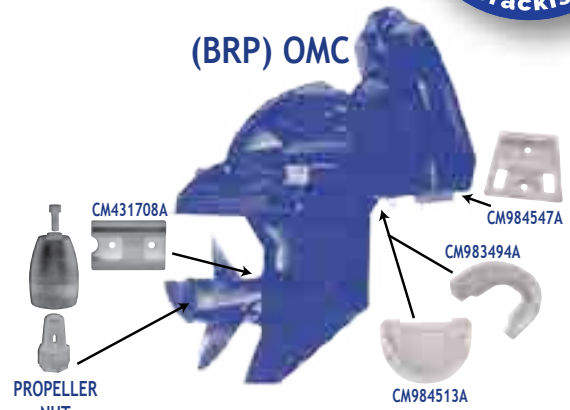

VOLVO

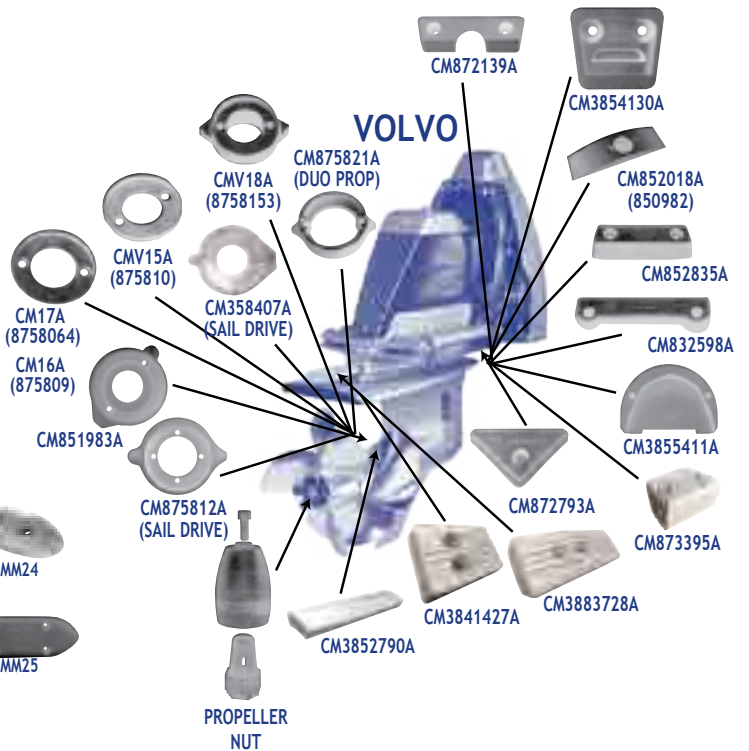

INBOARD APPLICATIONS

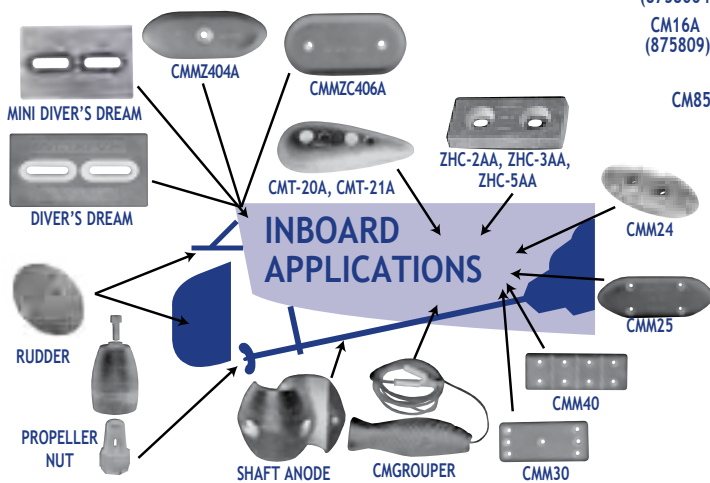

★ Kits available for Mercury, Yamaha & Volvo ★

sales@martyranodes.com • www.martyranodes.com
 See your dealer for full listing.

COMMERCIAL HULL ANODES

Notes:

1. All weights are nominal gross weight.
2. Inserts and straps are available in either Aluminum or steel.
3. Bolt size is suggested.
4. Contact us for special configuration requirements.
5. Detailed drawings are available. Protective backing available for better performance. Please check for details when ordering.

HULL ANODES

BOLT HOLES CAN BE ADDED ON STRAPS AS REQUIRED

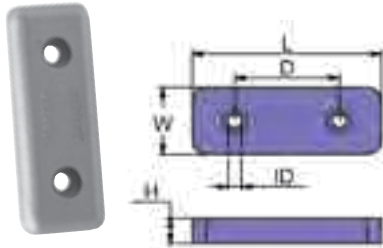

	PID	LB	KG		L	W	H	D	ID	UPC
Al	CM656934A	0.149	0.068	mm	83	31	11	46	6	6 28309 11551 7
Mg	CM656934M	0.092	0.042							6 28309 24283 1
Zn	CM656934Z	0.374	0.170	in	3.25	1.20	0.45	1.80	0.23	6 28309 11306 3

BOLT-ON

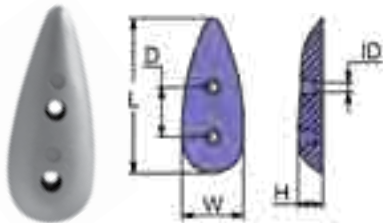

	PID	LB	KG		L	W	H	D	ID	UPC
Al	CMT20A	0.141	0.064	mm	86	46	15	33	6	6 28309 12398 7
Mg	CMT20M	0.090	0.041							6 28309 12191 4
Zn	CMT20	0.370	0.168	in	3.4	1.8	0.6	1.28	0.25	6 28309 10358 3

BOLT-ON

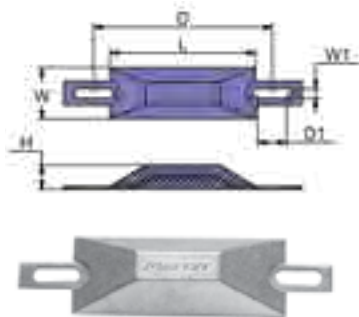

	PID	LB	KG		L	W	W1	H	D	D1	UPC
Al	CM200A	0.209	0.095	mm	96	34	6	16	117	19	6 28309 19355 3
Mg	CM200M	0.163	0.074								6 28309 19361 4
Zn	CM200Z	0.441	0.200	in	3.78	1.33	0.25	0.63	4.6	0.75	6 28309 11503 6
Al	CM200AA	0.161	0.073								6 28309 19356 0

COMBO

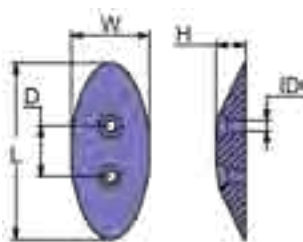

	PID	LB	KG		L	W	H	D	ID	UPC
Al	CMM24A	0.247	0.112	mm	111	49	18.5	32	6.7	6 28309 12376 5
Mg	CMM24M	0.152	0.069							6 28309 24353 1
Zn	CMM24	0.639	0.290	in	4.36	1.92	0.73	1.25	0.26	6 28309 10679 9

BOLT-ON

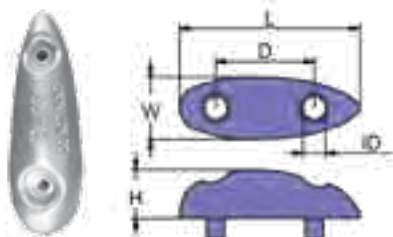

	PID	LB	KG		L	W	H	D	ID	UPC
Al	CMZ12SA	0.220	0.100	mm	92.96	31.49	24.38	51	6.7	6 28309 12074 0
Zn	CMZ12AZ	0.520	0.236	in	3.66	1.24	0.96	2	0.26	6 28309 11208 0

BOLT-ON

HULL ANODES

HULL ANODES

BOLT HOLES CAN BE ADDED ON STRAPS AS REQUIRED

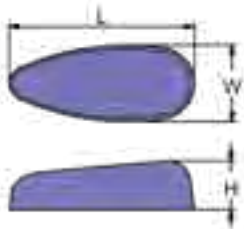

PID		LB	KG		L	W	H	UPC	
Al	CM335A	0.262	0.119	mm	85	36	21	6 28309 12399 4	
Mg	CM335M	0.165	0.075					Please contact us	
Zn	CM335Z	0.683	0.310	in	3.35	1.4	0.83	6 28309 12204 1	

BOLT-ON

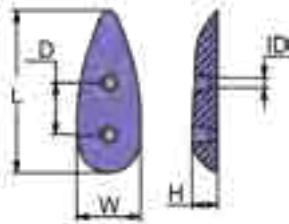

PID		LB	KG		L	W	H	D	ID	UPC	
Al	CMT21A	0.377	0.171	mm	129	51	21	41	8	6 28309 12396 3	
Mg	CMT21M	0.242	0.110							6 28309 24385 2	
Zn	CMT21	0.992	0.450	in	5	2	0.8	1.63	0.31	6 28309 10359 0	

BOLT-ON

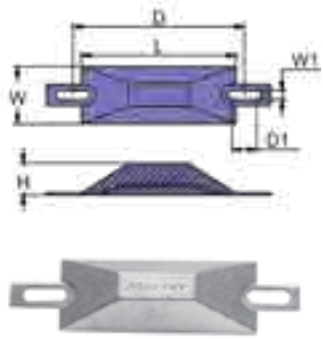

PID		LB	KG		L	W	W1	H	D	D1	UPC	
Al	CM500A	0.469	0.213	mm	116	43	7	24	128	19	6 28309 19357 7	
Mg	CM500M	0.328	0.149								6 28309 19362 1	
Zn	CM500Z	1.102	0.500	in	4.5	1.68	0.26	1	5	0.75	6 28309 11504 3	
Al	CM500AA	0.419	0.190								6 28309 19358 4	

COMBO

Martyr®
HULL ANODES

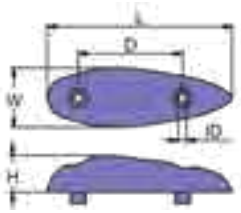

PID		LB	KG		L	W	H	D	ID	UPC	
Al	CMZ13SA	0.6	0.272	mm	145	47	29	83	6.7	6 28309 12071 9	
Zn	CMZ13AZ	1.45	0.635	in	5.75	1.84	1.14	3.25	0.26	6 28309 11209 7	

BOLT-ON

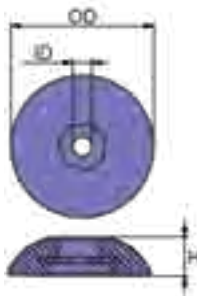

PID		LB	KG		OD	ID	H	UPC			
Al	CMZD56A	0.837	0.38	mm	102	14	28	6 28309 17316 6			
Mg	CMZD56M	0.573	0.26					6 28309 21462 3			
Zn	CMZD56	1.90	0.86	in	4	0.53	1.1	6 28309 12610 0			

BOLT-ON

HULL ANODES

BOLT HOLES CAN BE ADDED ON STRAPS AS REQUIRED

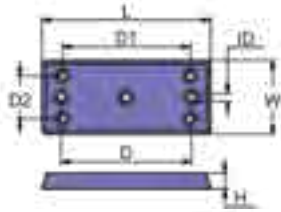

	PID	LB	KG		L	W	H	D	D1	D2	ID	UPC
Al	CMM30A	0.745	0.338	mm	154	68	14	121	118	40	7.1	6 28309 12378 9
Mg	CMM30M	0.469	0.213									6 28309 24355 5
Zn	CMM30	1.916	0.869	in	6.06	2.67	0.56	4.75	4.62	1.58	0.28	6 28309 10681 2

BOLT-ON

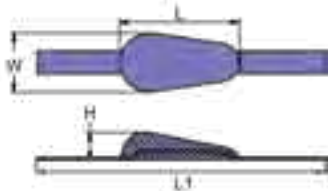

	PID	LB	KG		L	L1	W	H	UPC		
Al	CM35GA	1.05	0.47	mm	127	304.8	61	29.46	6 28309 12365 9		
Zn	CM35GZ	2.2	0.99	in	5	12	2.4	1.16	6 28309 12151 8		

WELD-ON

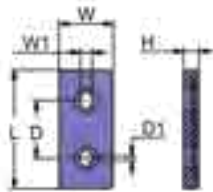

	PID	LB	KG		L	W	W1	H	D	D1	UPC	
Al	CMZHC3AA	0.765	0.347	mm	159	70	14	19	65	15	6 28309 11402 2	
Mg	CMZHC3AM	0.517	0.234								6 28309 26315 7	
Zn	CMZHC3AZ	1.925	0.873	in	6.25	2.75	0.54	0.75	2.57	0.57	6 28309 11226 4	

BOLT-ON

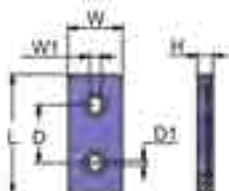

	PID	LB	KG		L	W	W1	H	D	D1	UPC	
Al	CMZHC2AA	0.887	0.402	mm	146	64	14.2	19	71	5.6	6 28309 11401 5	
Mg	CMZHC2AM	0.544	0.246								6 28309 17625 9	
Zn	CMZHC2AZ	2.215	1.004	in	5.75	2.65	0.56	0.75	2.78	0.22	6 28309 11225 7	

BOLT-ON

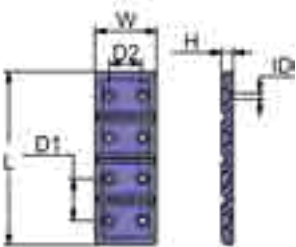

	PID	LB	KG		L	W	H	D1	D2	ID	UPC	
Al	CMM40A	0.815	0.370	mm	186	66	13	44	35	7	6 28309 12379 6	
Mg	CMM40M	0.529	0.240								6 28309 24356 2	
Zn	CMM40	2.094	0.950	in	7.3	2.6	0.5	1.75	1.38	0.25	6 28309 10682 9	

BOLT-ON

HULL ANODES

HULL ANODES

BOLT HOLES CAN BE ADDED ON STRAPS AS REQUIRED

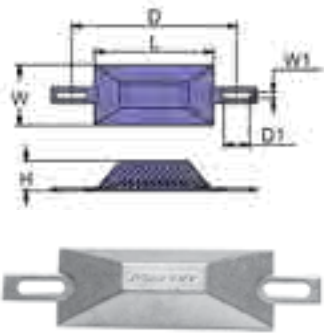

	PID	LB	KG		L	W	W1	H	D	D1	UPC
Al	CM1000A	0.904	0.410	mm	118	60	6	30	162	25	6 28309 19351 5
Mg	CM1000M	0.608	0.276								6 28309 19359 1
Zn	CM1000Z	2.205	1.0	in	4.12	2.25	0.25	1.18	6.38	1	6 28309 11502 9
Al	CM1000AA	0.839	0.381								6 28309 19352 2

COMBO

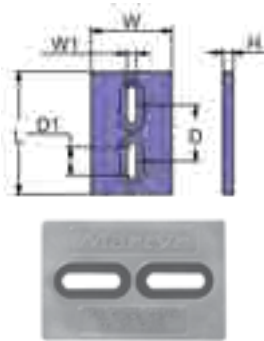

	PID	LB	KG		L	W	W1	H	D	D1	UPC
Al	CMDIVERMINIA	1.058	0.480	mm	150	99	11	13	69	35	6 28309 12375 8
Mg	CMDIVERMINIM	0.793	0.360								6 28309 11506 7
Zn	CMDIVERMINI	2.231	1.012	in	5.9	3.9	0.44	0.5	2.7	1.36	6 28309 11338 4

BOLT-ON

SEE PART ID: CMDIVERMINIHZ FOR A HEAVIER VERSION

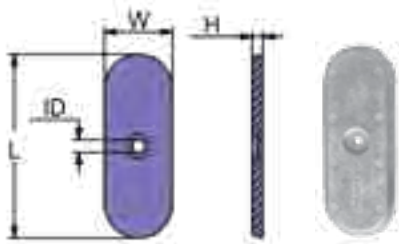

	PID	LB	KG		L	W	H	ID	UPC
Al	CMN1A	0.990	0.449	mm	216	80	13	10	6 28309 12347 5
Mg	CMN1M	0.626	0.284						6 28309 24357 9
Zn	CMN1Z	2.580	1.170	in	8.5	3.15	0.5	0.41	6 28309 12348 2

BOLT-ON

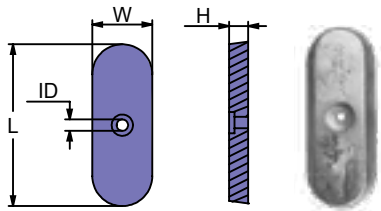

	PID	LB	KG		L	W	H	ID	UPC
Al	CMN1HA	1.892	0.858	mm	219	84	25.4	10	6 28309 27439 9
Mg	CMN1HM	1.206	0.547						6 28309 27440 5
Zn	CMN1HZ	4.904	2.224	in	8.63	3.31	1	0.4	6 28309 27438 2

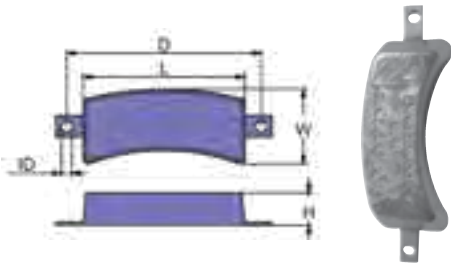

	PID	LB	KG		L	W	H	D	ID	UPC
Zn	CMH18BZ	2.90	1.32	mm	150	69	30	180	10	6 28309 24467 5
				in	6	2.75	1.19	7	0.37	

COMBO

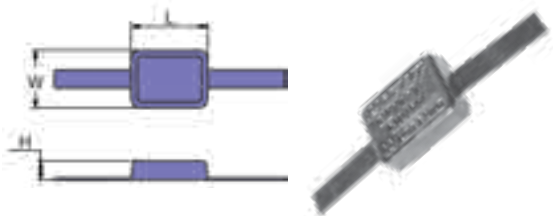

	PID	LB	KG		L	W	H	UPC
Al	CM2431GA	1.50	0.680	mm	102	76	25	6 28309 12362 8
Zn	CM2431GZ	3.14	1.424	in	4	3	1	6 28309 12143 3

WELD-ON

Martyr®
HULL ANODES

HULL ANODES

BOLT HOLES CAN BE ADDED ON STRAPS AS REQUIRED

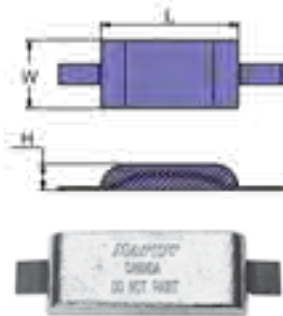

	PID	LB	KG		L	W	H	UPC
Al	CMZ06SA	1.260	0.571	mm	127	64	25	6 28309 11390 2
Mg	CMZ06SM	0.887	0.402					6 28309 18967 9
Zn	CMZ06SZ	2.860	1.297					6 28309 11205 9
Al	CMZ06AA	1.070	0.485	in	5	2.5	1	6 28309 11391 9
Mg	CMZ06AM	0.693	0.314					6 28309 18512 1
Zn	CMZ06AZ	2.670	1.211					6 28309 11206 6
Mg	CMZ06GM	0.887	0.402					6 28309 18969 3
Zn	CMZ06GZ	2.860	1.297	6 28309 12353 6				

WELD-ON

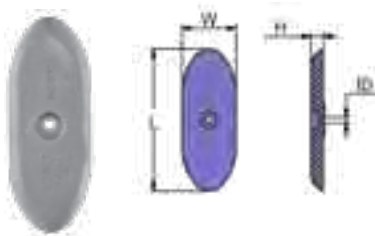

	PID	LB	KG		L	W	H	ID	UPC
Al	CMMZ404A	1.48	0.671	mm	224	86	19	10	6 28309 12380 2
Mg	CMMZ404M	0.95	0.431						6 28309 18507 7
Zn	CMMZ404	3.75	1.701	in	8.82	3.37	0.75	0.37	6 28309 11339 1

BOLT-ON

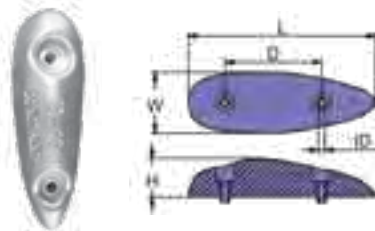

	PID	LB	KG		L	W	H	D	ID	UPC
Al	CMZ14SA	1.500	0.680	mm	197	64	42.42	101	6.7	6 28309 12080 1
Zn	CMZ14AZ	3.650	1.655							6 28309 11210 3
Al	CMZ14AA	1.414	0.641	in	7.75	2.5	1.67	4	0.26	6 28309 25905 1

BOLT-ON

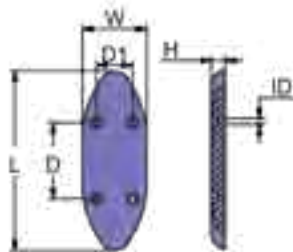

	PID	LB	KG		L	W	H	D	D1	ID	UPC
Al	CMM25A	1.292	0.586	mm	231	83	18	98	46	7	6 28309 12377 2
Mg	CMM25M	0.822	0.373								6 28309 24354 8
Zn	CMM25	3.390	1.538	in	9.08	3.25	0.72	3.86	1.81	0.28	6 28309 10680 5

BOLT-ON



	PID	LB	KG		L	W	H	UPC
Al	CM37GA	1.829	0.83	mm	177.8	71.1	38.1	6 28309 12361 1
Zn	CM37GZ	4.233	1.92	in	7	2.8	1.5	6 28309 12150 1

WELD-ON



HULL ANODES

HULL ANODES

BOLT HOLES CAN BE ADDED ON STRAPS AS REQUIRED

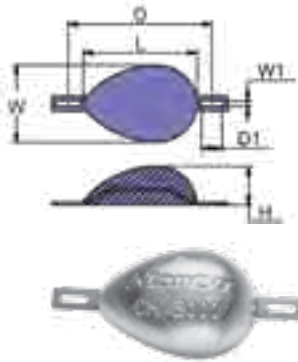

	PID	LB	KG		L	W	W1	H	D	D1	UPC
Al	CM2000A	2.140	0.971	mm	141	96	6	48	184	19	6 28309 19353 9
Mg	CM2000M	1.488	0.675		6 28309 19360 7						
Zn	CM2000Z	4.627	2.099	in	5.55	3.78	0.25	1.9	7.24	0.75	6 28309 11932 4
Al	CM2000AA	1.997	0.906		6 28309 19354 6						

COMBO

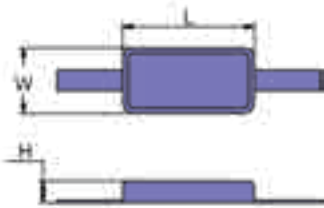

	PID	LB	KG		L	W	H	UPC
Al	CM2631GA	1.90	0.90	mm	152	76	25	6 28309 12364 2
Zn	CM2631GZ	4.50	2.00	in	6	3	1	6 28309 12144 0

WELD-ON

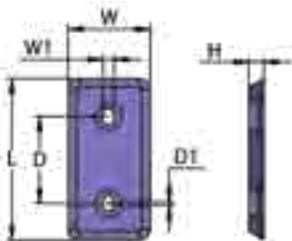

	PID	LB	KG		L	W	W1	H	D	D1	UPC
Al	CMZHC5AA	1.80	0.81	mm	203	102	14	19	110	6	6 28309 12312 3
Mg	CMZHC5AM	1.18	0.53		6 28309 24421 7						
Zn	CMZHC5AZ	4.68	2.12	in	8	4	0.55	0.76	4.35	0.23	6 28309 11228 8

BOLT-ON

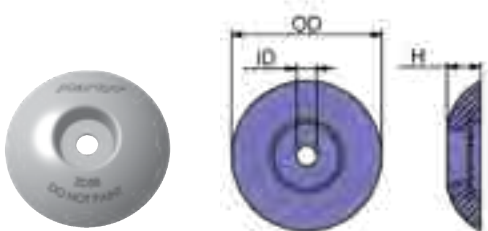

	PID	LB	KG		OD	ID	H	UPC
Al	CMZD58A	2.116	0.96	mm	150	20	34	6 28309 24258 9
Zn	CMZD58	5.004	2.27	in	5.9	0.79	1.34	6 28309 12639 1

BOLT-ON

Martyr®
HULL ANODES

HULL ANODES

BOLT HOLES CAN BE ADDED ON STRAPS AS REQUIRED



PID		LB	KG		L	W	H	UPC	
Al	CMZC5SA	1.85	0.84	mm	224	56	28	6	28309 11399 5
Zn	CMZC5SZ	4.9	2.22					6	28309 20141 8
Al	CMZC5AA	1.521	0.69	in	8.8	2.2	1.1	6	28309 27121 3
Zn	CMZC5AZ	4.387	1.99					6	28309 20141 8

WELD-ON

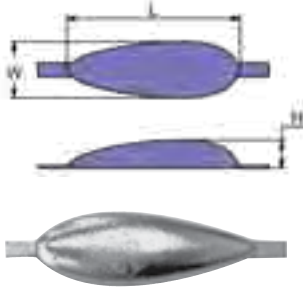

PID		LB	KG		L	W	H	UPC	
Al	CMZTSA	2.20	0.998	mm	229	73.025	38	6	28309 11406 0
Zn	CMZTSZ	5.10	2.313					6	28309 11285 1
Al	CMZTSA A	2.00	0.907					6	28309 11407 7
Zn	CMZTSA Z	4.90	2.222	in	9	2.875	1.5	6	28309 11286 8
Al	CMZTSGA	2.20	0.998					6	28309 11237 0
Zn	CMZTSGZ	5.10	2.313					6	28309 11287 5

WELD-ON

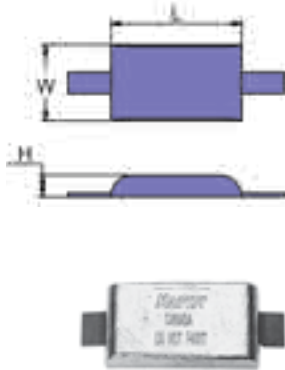

PID		LB	KG		L	W	H	UPC	
Al	CMZ04SA	2.30	1.043	mm	152	89	25	6	28309 11388 9
Mg	CMZ04SM	1.69	0.766					6	28309 18511 4
Zn	CMZ04SZ	5.41	2.454					6	28309 11203 5
Al	CMZ04AA	2.09	0.948	in	6	3.5	1	6	28309 11389 6
Mg	CMZ04AM	1.34	0.608					6	28309 18510 7
Zn	CMZ04AZ	4.96	2.249					6	28309 12019 1
Mg	CMZ04GM	1.73	0.784					6	28309 18968 6
Zn	CMZ04GZ	5.45	2.472					6	28309 12367 3

WELD-ON

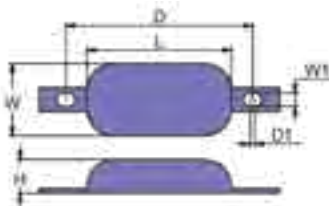

PID		LB	KG		L	W	W1	H	D	D1	UPC	
Al	CMHT1A	2.42	1.10	mm	152	76	14	36	197	5	6	28309 12541 7
Zn	CMHT1	5.10	2.30	in	6	3	0.56	1.4	7.75	0.19	6	28309 11952 2

COMBO



PID		LB	KG		L	W	W1	H	D	D1	UPC	
Al	CMZD77EUROA	2.160	0.98	mm	318	67	12	34	155	55	6	28309 18965 5
Mg	CMZD77EUROM	1.455	0.66								6	28309 19248 8
Zn	CMZD77EURO	5.114	2.32	in	12.5	2.6	0.47	1.3	6.1	2.17	6	28309 12607 0

BOLT-ON

HULL ANODES

Choose
Aluminum

Al premium
SALT AND BRACKISH WATER

Anodes for
salt and brackish
water and
Magnesium

Mg fresh
FRESH WATER ONLY
for freshwater.

HULL ANODES

BOLT HOLES CAN BE ADDED ON STRAPS AS REQUIRED

	PID	LB	KG		L	W	H	UPC
Al	CM273125GA	2.20	1.00	mm	152	76	35	6 28309 12359 8
Zn	CM273125GZ	5.50	2.50	in	6	3	1.38	6 28309 12146 4

WELD-ON



	PID	LB	KG		L	W	H	UPC
Al	CM39315GA	2.301	1.044	mm	208	76	38	6 28309 12366 6
Zn	CM39315GZ	5.414	2.456					6 28309 12152 5
Zn	CM39315AZ	5.176	2.348	in	8.2	3	1.5	6 28309 12997 2

WELD-ON

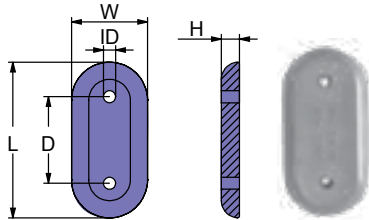

	PID	LB	KG		L	W	H	D	ID	UPC
Al	CMMZC406A	3.280	1.487	mm	229	112	25	127	13	6 28309 12381 9
Mg	CMMZC406M	2.140	0.970							6 28309 17620 4
Zn	CMMZC406	8.150	3.696	in	9	4.4	1	5	0.5	6 28309 11340 7

BOLT-ON

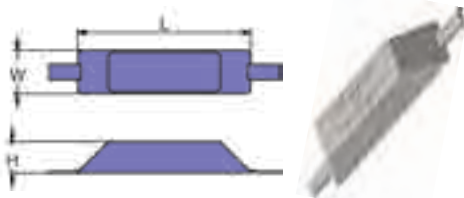

	PID	LB	KG		L	W	H	UPC
Al	CMZC7SA	2.77	1.256	mm	228	57	46	6 28309 11400 8
Zn	CMZC7SZ	6.83	3.098					6 28309 11223 3
Al	CMZC7AA	2.56	1.161	in	9	2.25	1.82	6 28309 27097 1

WELD-ON

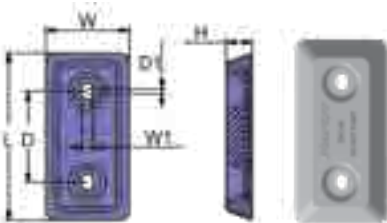

	PID	LB	KG		L	W	W1	H	D	D1	UPC
Al	CMZHC06GBA	3.020	1.37	mm	203	101	14	32	111	6	6 28309 24264 0
Zn	CMZHC06GBZ	7.054	3.20	in	8	4	0.55	1.25	4.35	0.23	6 28309 16617 5

BOLT-ON

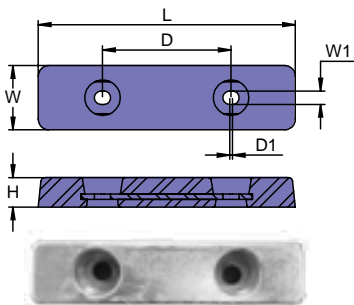

	PID	LB	KG		L	W	H	D	W1	D1	UPC
Al	CMZSC12A	4.5	2.04	mm	305	76	35	152	16	3	6 28309 27499 3
Mg	CMZSC12M	3.1	1.41								6 28309 27500 8
Zn	CMZSC12Z	10.4	4.72	in	12	3	1.375	6	0.63	0.12	6 28309 27498 8

BOLT-ON

Martyr
HULL ANODES

NEW
PRODUCT

HULL ANODES

BOLT HOLES CAN BE ADDED ON STRAPS AS REQUIRED



	PID	LB	KG		L	W	H	D	ID	UPC
Mg	CMMGJRGM	2.00	0.91	mm	226	96	40	286	10	6 28309 15549 0
				in	8.9	3.75	1.5	11.25	0.37	

COMBO WITH PLASTISOL COAT

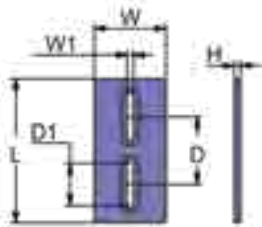

	PID	LB	KG		L	W	W1	H	D	D1	UPC
Al	CMDIVERA	3.48	1.58	mm	305	152	13.21	12.7	140	88.39	6 28309 10183 1
Mg	CMDIVERM	2.50	1.14								6 28309 11507 4
Zn	CMDIVERZ	7.52	3.41	in	12	6	0.52	0.5	5.5	3.48	6 28309 11365 0



BOLT-ON ALUMINUM VERSION NOW AVAILABLE IN PACKAGED KIT WITH ALL HARDWARE INCLUDED. PART ID: CMDIVERBOND FOR A HEAVIER VERSION: PART ID: CMDIVERH

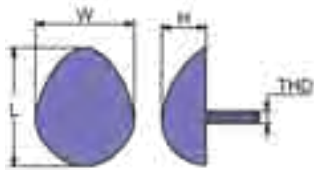

	PID	LB	KG		L	W	H	THD	UPC
Al	CM36BSSA	3.50	1.60	mm	152	127	57	3/8-16 NC	6 28309 12402 1
Zn	CM36BSSZ	8.75	3.97	in	6	5	2.25		6 28309 12153 2

BOLT-ON

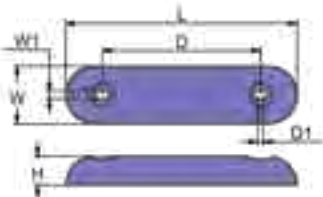

	PID	LB	KG		L	W	W1	H	D	D1	UPC
Al	CMZD78BA	3.57	1.62	mm	305	76	10	38	208	8	6 28309 18964 8
Zn	CMZD78B	9.00	4.00	in	12	3	0.39	1.5	8.19	0.29	6 28309 12609 4

BOLT-ON

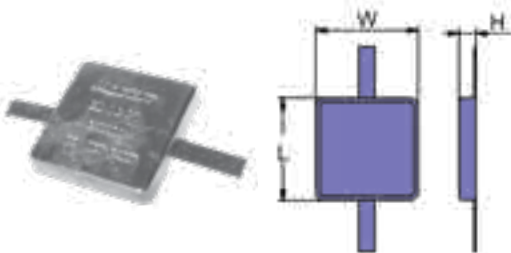

	PID	LB	KG		L	W	H	UPC
Al	CM1661GA	3.80	1.72	mm	152	152	25	6 28309 12363 5
Zn	CM1661GZ	9.00	4.00	in	6	6	1	6 28309 12145 7

WELD-ON

HULL ANODES

HULL ANODES

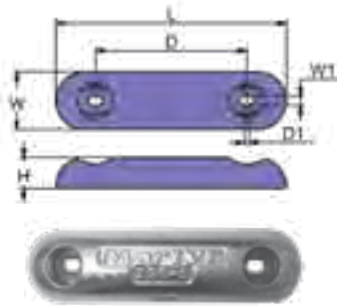

BOLT HOLES CAN BE ADDED ON STRAPS AS REQUIRED

	PID	LB	KG		L	W	W1	H	D	D1	UPC
Al	CMZ03BSA	3.91	1.773	mm	305	76	14	41	200	4.83	6 28309 12857 9
Zn	CMZ03BSZ	8.90	4.037								6 28309 12733 6
Al	CMZ03BSAA	3.48	1.578	in	12	3	0.56	1.6	7.88	0.19	6 28309 25022 5

BOLT-ON

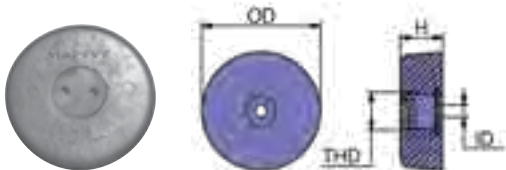

	PID	LB	KG		OD	ID	H	THD	UPC
Al	CMH06A (AZIMUT)	3.63	1.65	mm	135	16	50	M45	6 28309 12475 5
Zn	CMH06Z (AZIMUT)	9.24	4.20	in	5.3	0.63	2	x 2	6 28309 11490 9

BOLT-ON

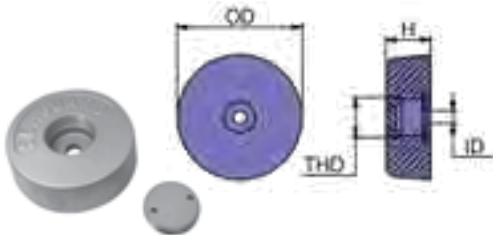

	PID	LB	KG		OD	ID	H	THD	UPC
Al	CMF125PB4TPA	2.286	1.037	mm	125	15	38	M50 x 3	6 28309 24668 6
Mg	CMF125PB4TPM	1.591	0.722						6 28309 24683 9
Zn	CMF125PB4TPZ	5.879	2.667	in	4.92	0.59	1.49		6 28309 24656 3

BOLT-ON

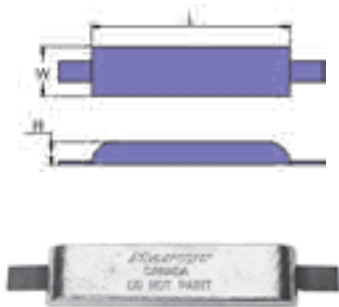

	PID	LB	KG		L	W	H	UPC
Al	CMZ03SA	5.30	2.404	mm	305	76	35	6 28309 11385 8
Mg	CMZ03SM	3.50	1.587					6 28309 19084 2
Zn	CMZ03SZ	10.90	4.944					6 28309 11198 4
Al	CMZ03AA	4.60	2.086					6 28309 11386 5
Mg	CMZ03AM	2.80	1.270	in	12	3	1.37	6 28309 19083 5
Zn	CMZ03AZ	10.20	4.626					6 28309 11199 1
Al	CMZ03GA	5.30	2.404					6 28309 12370 3
Zn	CMZ03GZ	10.90	4.944					6 28309 11202 8

WELD-ON

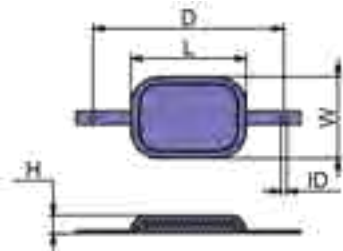

	PID	LB	KG		ID	D	L	W	H	UPC
Al	CMCDZ886SA	5.147	2.335	mm	10	340	203	145	34	6 28309 26296 9
Mg	CMCDZ886SM	3.587	1.627							6 28309 26309 6
Zn	CMCDZ886SZ	11.997	5.442	in	0.39	13.38	7.99	5.70	1.34	6 28309 26283 9

COMBO

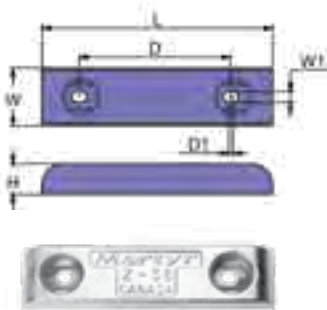

	PID	LB	KG		L	W	W1	H	D	D1	UPC
Al	CMZ03BA	4.98	2.259	mm	305	76	14	41	200	5	6 28309 11387 2
Zn	CMZ03BZ	11.62	5.270								6 28309 11200 4
Al	CMZ03BGA	4.98	2.259								Please contact us
Zn	CMZ03BGZ	11.62	5.270	in	12	3	0.56	1.6	7.88	0.19	6 28309 12410 6
Al	CMZ03BAA	4.55	2.064								6 28309 18026 3
Zn	CMZ03BAZ	11.19	5.075								6 28309 16633 5

BOLT-ON

Martyr®
HULL ANODES

HULL ANODES

BOLT HOLES CAN BE ADDED ON STRAPS AS REQUIRED

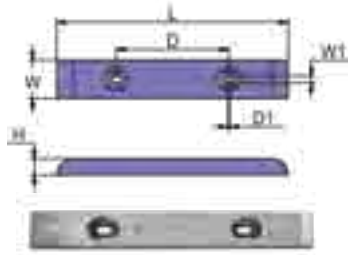

	PID	LB	KG		L	W	W1	H	D	D1	UPC
Al	CMZ15BA	5.76	2.61	mm	457	76	16.5	33	235	6	6 28309 12017 1 7
Zn	CMZ15BZ	15.20	6.90	in	18	3	0.65	1.3	9.25	0.25	6 28309 11211 1 0

BOLT-ON

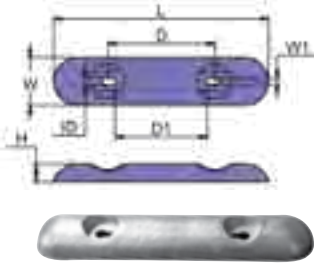

	PID	LB	KG		L	W	W1	H	D	D1	ID	UPC
Al	CMZD72BMA	6.85	3.11	mm	457	102	12	38	229	197	19	6 28309 12789 1 3
Mg	CMZD72BMM	4.72	2.14									6 28309 25551 1 0
Zn	CMZD72BM	16.2	7.35	in	18	4	0.48	1.5	9	7.75	0.75	6 28309 12605 1 6

BOLT-ON

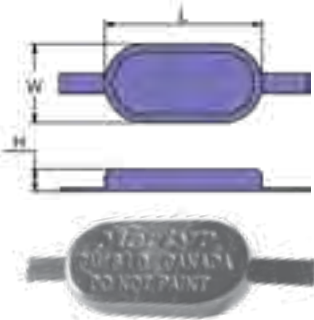

	PID	LB	KG		L	W	H	UPC
Al	CM810SA	6.19	2.81	mm	248	125	35	6 28309 12401 1 4
Zn	CM810SZ	14.35	6.51	in	9.75	4.9	1.37	6 28309 12147 1 1

WELD-ON

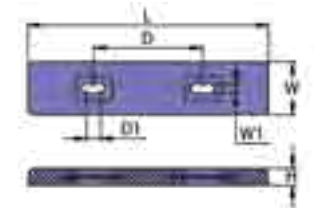

	PID	LB	KG		L	W	H	D	D1	W1	UPC
Al	CMZL18BGA	8.09	3.67	mm	454	100	32	204.8	26.2	17.6	6 28309 25525 1 1
Mg	CMZL18BGM	5.72	2.59								6 28309 25530 1 5
Zn	CMZL18BGZ	18.56	8.42	in	17.87	3.93	1.25	8.06	1.03	0.69	6 28309 25520 1 6

BOLT-ON

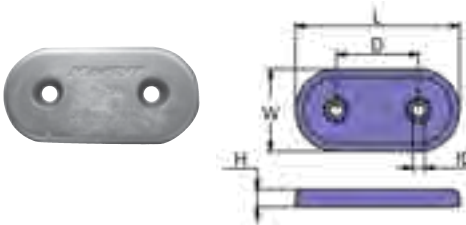

	PID	LB	KG		L	W	H	D	ID	UPC
Al	CMH20BA	8.126	3.686	mm	305	152	48	152	22	6 28309 24209 1 1
Mg	CMH20BM	5.454	2.474							6 28309 24335 1 7
Zn	CMH20BZ	19.841	9.000	in	12	6	1.3	6	0.86	6 28309 24131 1 5

BOLT-ON

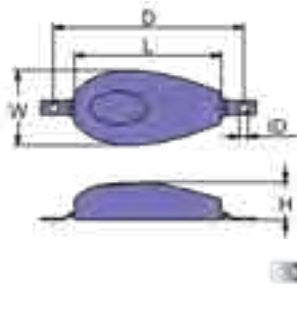

	PID	LB	KG		L	W	H	D	ID	UPC
Mg	CMMG5GM	5.04	2.29	mm	259	132	66	336	16	6 28309 15548 1 3
				in	10.2	5.2	2.6	13.2	0.63	

COMBO

HULL ANODES

Choose
Aluminum

Al premium
SALT AND BRACKISH WATER

Anodes for
salt and brackish
water and
Magnesium

Mg fresh
FRESH WATER ONLY
for freshwater.

HULL ANODES

BOLT HOLES CAN BE ADDED ON STRAPS AS REQUIRED

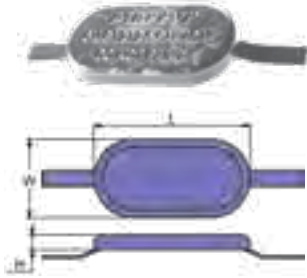

	PID	LB	KG		L	W	H	UPC
Al	CM812125SA	7.93	3.60	in	12	6	1.15	6 28309 12335 2
Zn	CM812125SZ	18.74	8.50	mm	305	152	29	6 28309 12491 5
Al	CM812125GA	7.93	3.60	in	12	6	1.15	6 28309 12335 2
Zn	CM812125GZ	18.74	8.50	mm	305	152	29	6 28309 12491 5

WELD-ON

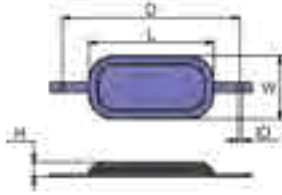

	PID	LB	KG		ID	D	L	W	H	UPC
Al	CMCDZ8126SA	8.287	3.759	mm	10	440	308	155	35.5	6 28309 26295 2
Mg	CMCDZ8126SM	5.657	2.566							6 28309 26308 9
Zn	CMCDZ8126SZ	19.824	8.992	in	0.39	17.32	12.13	6.10	1.40	6 28309 26282 2

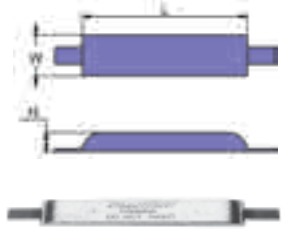

	PID	LB	KG		L	W	H	UPC
Al	CMZ19SA	11.10	5.035	mm	635	76.2	33	6 28309 11395 7
				in	25	3	1.3	
Zn	CMZ19SZ	23.30	10.568	mm	635	76.2	30.5	6 28309 11212 7
Zn	CMZ19AZ	22.10	10.024	in	25	3	1.2	6 28309 11213 4

WELD-ON

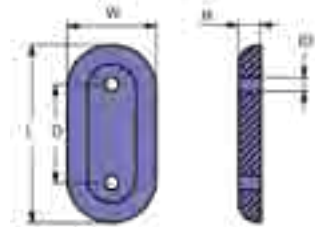

	PID	LB	KG		L	W	H	D	ID	UPC
Al	CMZ24BSA	8.40	3.810	mm	356	159	28.58	127	13	6 28309 12563 9
Mg	CMZ24BSM	5.10	2.313							6 28309 24414 9
Zn	CMZ24BSZ	21.00	9.525	in	14	6.25	1.125	5	0.5	6 28309 12482 3

BOLT-ON

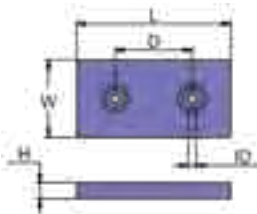

	PID	LB	KG		L	W	H	D	ID	UPC
Al	CMZ01BSA	9.8	4.44	mm	305	152	32	152	16	6 28309 11382 7
Mg	CMZ01BSM	6.72	3.048							6 28309 18508 4
Zn	CMZ01BSZ	21.34	9.679	in	12	6.256	1.25	6	0.62	6 28309 11193 9

BOLT-ON

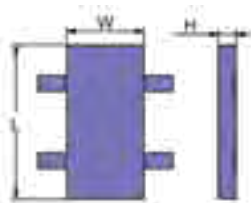

	PID	LB	KG		L	W	H	UPC
Al	CMZ02SA	10.55	4.79	mm	305	152	35	6 28309 11383 4
Zn	CMZ02SZ	23.50	10.86	in	12	6	1.38	6 28309 11195 3

WELD-ON

Martyr
HULL ANODES

HULL ANODES

BOLT HOLES CAN BE ADDED ON STRAPS AS REQUIRED

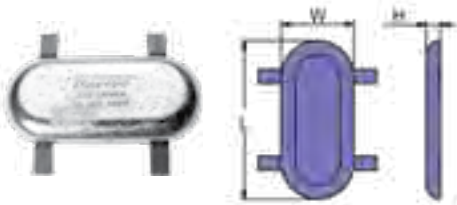

	PID	LB	KG		L	W	H	UPC
Al	CMZ22SA	11.400	5.171	mm	356	165	36	6 28309 11396 4
Al	CMZ22AA	10.600	4.808	in	14	6.5	1.4	6 28309 11215 8
Zn	CMZ22AZ	23.400	10.614	mm	356	165	33	6 28309 11942 3
Mg	CMZ22SM	6.938	3.147					6 28309 18974 7
Mg	CMZ22AM	6.138	2.784	in	14	6.5	1.3	6 28309 18975 4
Mg	CMZ22GM	6.938	3.147					6 28309 18976 1
Zn	CMZ22SZ	24.200	10.977					6 28309 11214 1

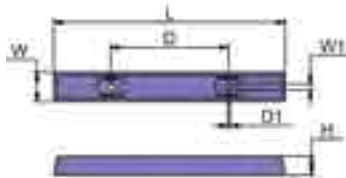

WELD-ON

	PID	LB	KG		L	W	W1	H	D	D1	UPC
Al	CMP5B2BSA	11.40	5.171	mm	610	79	16	51	311	6	6 28309 11810 5
Zn	CMP5B2BSZ	24.60	11.158								6 28309 11453 4
Al	CMP5B2BGS	11.40	5.171	in	24	3.1	0.63	2	12.25	0.25	6 28309 12864 7
Zn	CMP5B2BGSZ	24.60	11.158								6 28309 13016 9
Al	CMP5B2BAA	10.61	4.812								6 28309 12576 9
Zn	CMP5B2BAZ	23.81	10.800	6 28309 12575 2							



BOLT-ON

	PID	LB	KG		L	W	W1	H	D	D1	UPC
Al	CMZD72BA	10.61	4.812	mm	455	102	19	56	226	9	6 28309 18287 8
Zn	CMZD72B	25.29	11.471	in	17.9	4	0.73	2.2	8.9	0.35	6 28309 12625 4

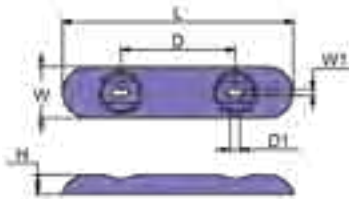

BOLT-ON

	PID	LB	KG		L	W	H	UPC
Al	CMZ26SA	10.90	4.944	mm	338	109	57	6 28309 11398 8
Zn	CMZ26SZ	25.30	11.476					6 28309 11944 7
Al	CMZ26AA	9.70	4.399	in	13.3	4.3	2.25	6 28309 125389 9
Zn	CMZ26AZ	24.40	11.067					6 28309 12081 8
Zn	CMZ26GZ	25.30	11.476					6 28309 17128 5



WELD-ON

	PID	LB	KG		L	W	H	D	ID	UPC
Al	CMH19BA	10.58	4.80	mm	305	152	48	152	22	6 28309 124208 4
Mg	CMH19BM	6.96	3.16	in	12	6	1.9	6	0.87	6 28309 124334 0
Zn	CMH19BZ	26.70	12.00							6 28309 124130 8

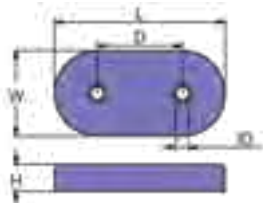

BOLT-ON



HULL ANODES

Protect your boat, respect our waters.

HULL ANODES

BOLT HOLES CAN BE ADDED ON STRAPS AS REQUIRED

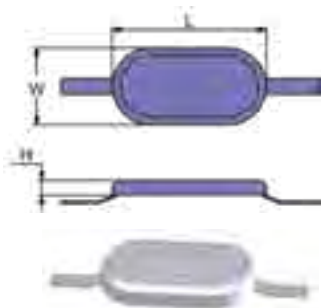

	PID	LB	KG		L	W	H	UPC
Al	CM812SA	11.905	5.40	mm	305	152	43	6 28309 18129 1
Zn	CM812SZ	29.101	13.20					6 28309 12148 8
Al	CM812GA	11.905	5.40	in	12	6	1.7	6 28309 12334 5
Zn	CM812GZ	29.101	13.20					6 28309 12492 2

WELD-ON

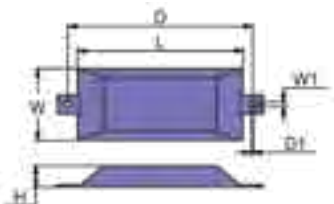

	PID	LB	KG		L	W	W1	H	D	D1	UPC
Al	CMM120BA	12.3	5.6	mm	350	152	18	45	390	4	6 28309 24223 7
Zn	CMM120BZ	30.0	13.5	in	13.75	6	0.71	1.75	15.37	0.5	6 28309 24136 0

COMBO

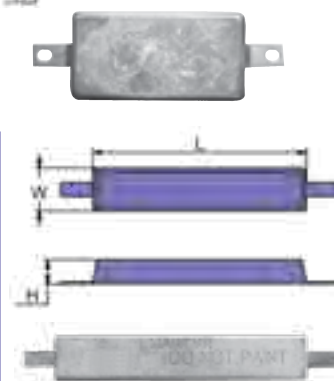

	PID	LB	KG		L	W	H	UPC
Al	CMMA2204SA	16.093	7.30	mm	508	101	57	6 28309 11409 1
Zn	CMMA2204SZ	36.596	16.60					6 28309 11493 0
Al	CMMA2204GA	16.093	7.30	in	20	4	2.25	6 28309 12336 9
Zn	CMMA2204GZ	36.596	16.60					6 28309 12820 3

WELD-ON

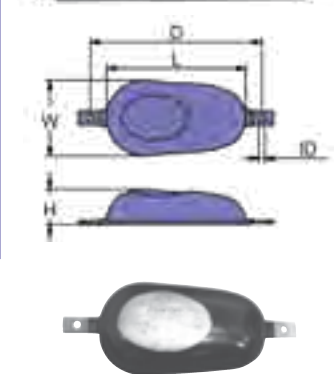

	PID	LB	KG		L	W	H	D	ID	UPC
Mg	CMMG10GM	9.97	4.53	mm	308	168	78	380	13.5	6 28309 15546 9
				in	12	6.6	3.1	15	0.53	

COMBO

WITH PLASTISOL COATING

	PID	LB	KG		L	W	H	D	ID	UPC
Al	CMMG10GA	13.54	6.14	mm	303	162	76	380	13.5	6 28309 21123 3
				in	11.93	6.37	2.99	15	0.53	

WITHOUT PLASTISOL COATING

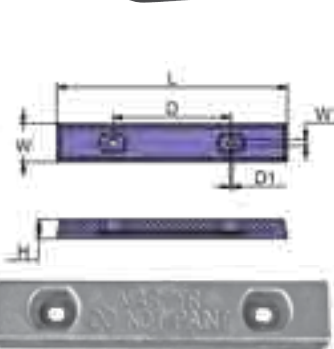

	PID	LB	KG		L	W	W1	H	D	D1	UPC
Al	CMP7B2BSA /CMZHC50A	19.3	8.75	mm	609	102	16	51	311	6	6 28309 11811 2
Zn	CMP7B2BSZ /CMZHC50Z	42.5	19.27	in	24	4	0.63	2	12.25	0.25	6 28309 11454 1

BOLT-ON

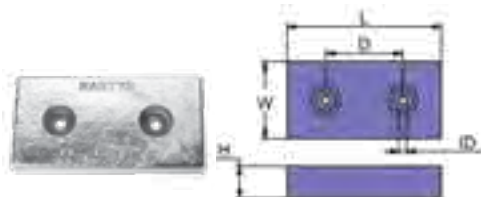

	PID	LB	KG		L	W	H	D	ID	UPC
Al	CMZHC47SA /CMAHC20SBS	16.30	7.393	mm	305	152	64	152	16	6 28309 12581 3
Zn	CMZHC47SZ /CMZHC42SBS	41.60	18.869	in	12	6	2.5	6	0.62	6 28309 11227 1

BOLT-ON

HULL ANODES

BOLT HOLES CAN BE ADDED ON STRAPS AS REQUIRED

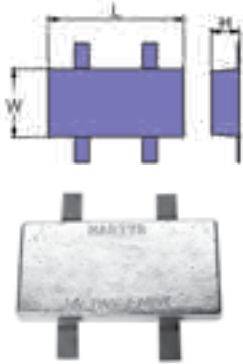

PID		LB	KG		L	W	H	UPC	
Al	CMZHS47SA/CMZHS20S	18.10	8.23	mm	305	152	64	6	28309 11403 9
Zn	CMZHS47SZ /CMZHS42S	45.00	20.50	in	12	6	2.5	6	28309 11229 5

WELD-ON

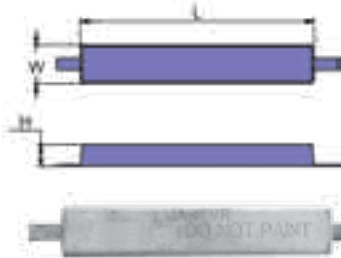

PID		LB	KG		L	W	H	UPC	
Al	CMMA2244LSA/CMZHS50A	19.7	8.75	mm	616	101	57	6	28309 12509 7
Zn	CMMA2244LSZ/CMZHS50Z	47.0	21.0	in	24.25	4	2.25	6	28309 13015 2

WELD-ON

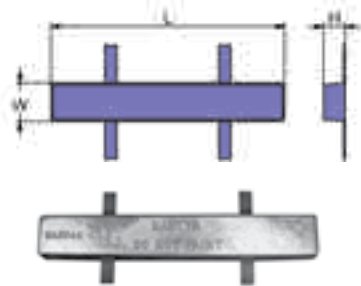

PID		LB	KG		L	W	H	UPC	
Al	CMMA2244SA	19.70	8.75	mm	609	101	50	6	28309 11410 7
Zn	CMMA2244SZ	47	21.32	in	24	4	2	6	28309 11806 8

WELD-ON

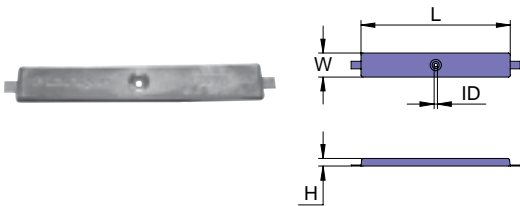

PID		LB	KG		L	W	H	ID	UPC	
Al	CM260SA	23.0	10.43	mm	800	128	40	18	6	28309 24163 6
Mg	CM260SM	16.58	7.52						6	28309 23228 9
Zn	CM260SZ	61.92	28.08	in	31.5	5	1.57	0.75	6	28309 24098 1

WELD-ON

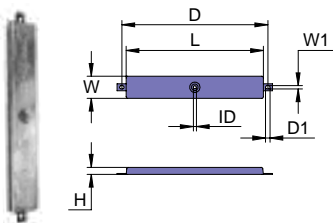

PID		LB	KG		L	W	H	ID	D	D1	W1	UPC	
Al	CM260BSA	22.93	10.40	mm	800	128	40	18	850	26	18	6	283092 771780
Mg	CM260BSM	16.51	7.49									6	283092 771858
Zn	CM260BSZ	61.84	28.05	in	31.5	5	1.57	0.75	33.46	1.02	0.71	6	283092 771812

BOLT-ON

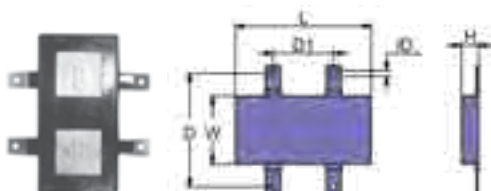

PID		LB	KG		L	W	H	D	D1	ID	UPC	
Mg	CMMG24GM	25.00	11.34	mm	457	229	58	381	203	19	6	28309 16592 5
				in	18	9	2.25	15	8	0.75		

COMBO WITH PLASTISOL COATING

HULL ANODES

Choose
Aluminum

Al premium
SALT AND BRACKISH WATER

Anodes for
salt and brackish
water and
Magnesium

Mg fresh
FRESH WATER ONLY
for freshwater.

HULL ANODES

BOLT HOLES CAN BE ADDED ON STRAPS AS REQUIRED

	PID	LB	KG		L	W	H	UPC
Al	CMMA3305SA	30.30	13.74	mm	745	119	66	6 28309 12862 3
Zn	CMMA3305SZ	76.70	34.79	in	29.3	4.7	2.6	6 28309 12056 6

WELD-ON

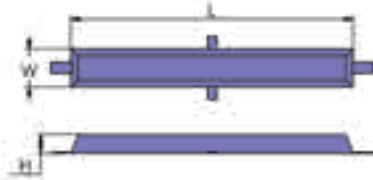
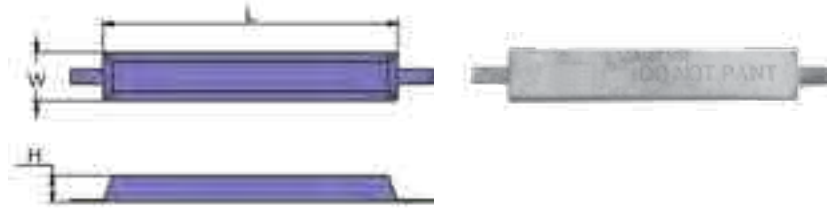

	PID	LB	KG		L	W	H	UPC
Al	CMMA3365CSA	38.30	17.40	mm	930	127	64	6 28309 11414 5
Zn	CMMA3365CSZ	88.00	39.91	in	36.6	5	2.5	6 28309 11945 4

WELD-ON

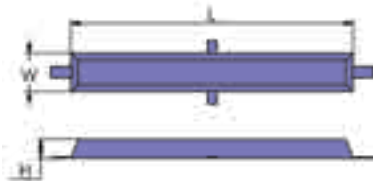

	PID	LB	KG		L	W	H	UPC
Al	CMMA4545CSA	98.00	44.50	mm	1379	127	109	6 28309 12547 9
Zn	CMMA4545CSZ	232.00	105.23	in	54.3	5	4.3	6 28309 12548 6

WELD-ON



Martyr
HULL ANODES

BALLAST TANK ANODES

BOLT HOLES CAN BE ADDED ON STRAPS AS REQUIRED

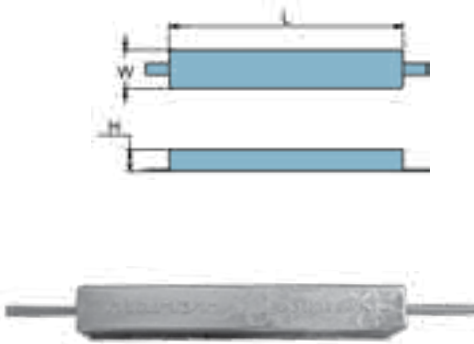

	PID	LB	KG		L	W	H	UPC
Al	CMMA2602SA	25.00	11.00	mm	1524	50	50	6 28309 12049 8
Zn	CMMA2602SZ	55.00	25.00	in	60	2	2	6 28309 12093 1
Al	CMMA3602SA	35.00	16.00	mm	1524	64	76	6 28309 24581 8
Zn	CMMA3602SZ	85.00	38.50	in	60	2.5	3	6 28309 24470 5
Al	CMMA31003A	115.00	52.00	mm	2540	89	83	6 28309 12543 1
Zn	CMMA31003Z	280.00	127.00	in	100	3.5	3.25	6 28309 12544 8
Al	CMMA41004A	140.00	63.50	mm	2540	102	95	6 28309 12141 9
Zn	CMMA41004Z	335.00	152.00	in	100	4	3.75	6 28309 12546 2

AVAILABLE IN ANY LENGTH & WEIGHT UP TO THE MAXIMUM SIZE SHOWN. 2602s & 3602s USE 0.5" ROD, 31003 USES 0.75" ROD.

CABLE ANODES



	PID	LB	KG		L	W	H	UPC
Al	CMTYPE3A	211.2	96	mm	1120	200	200	6 28309 24255 8
Zn	CMTYPE3Z	551.00	250.00	in	44	7.87	7.87	6 28309 24150 6

CUSTOM CABLE ANODES AVAILABLE UPON REQUEST. PLEASE CONTACT FOR DETAILS. CABLE DIAMETER AVAILABLE IN 1/2", 3/8", 5/8", AND 5/16".

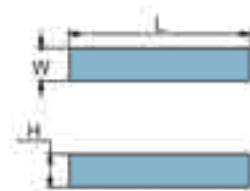

CONDENSER ANODES

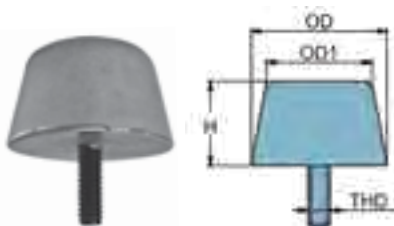

	PID	LB	KG		OD	OD1	H	THD	UPC
Al	CMC6C50BA	0.29	0.13	mm	50	38	30	5/16-24 UNF	6 28309 24195 7
Zn	CMC6C50BZ	0.73	0.33	in	1.97	1.5	1.18		6 28309 24119 3
Al	CMC6C75BA	0.69	0.31	mm	75	62	30	5/16-24 UNF	6 28309 24196 4
Zn	CMC6C75BZ	1.76	0.80	in	2.95	2.42	1.18		6 28309 24120 9

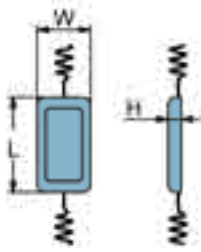

CRAB TRAP ANODES

	PID	LB	KG		L	W	H	UPC
Al	CMZCT2WA	0.70	0.32	mm	177	25	19	6 28309 12564 6
Zn	CMZCT2WZ	1.70	0.75	in	7	1	0.75	6 28309 11224 0

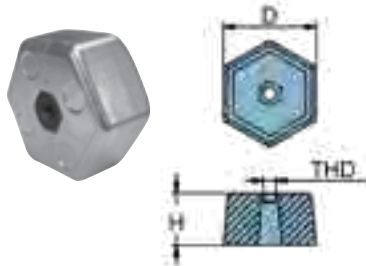

	PID	LB	KG		D	H	THD	UPC
Al	CMCTHBA	1.10	0.50	mm	76	43	1/2-13 UNC	6 28309 12725 1
Mg	CMCTHBM	0.705	0.320					6 28309 25037 9
Zn	CMCTHBZ	2.811	1.275	in	3	1.7		6 28309 13001 5

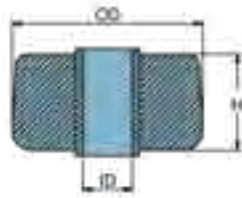

HEAT EXCHANGER ANODES

	PID	LB	KG		OD	H	UPC
Al	CMH2B2A	0.30	0.15	mm	50	25	6 28309 24210 7
Zn	CMH2B2Z	0.80	0.35	in	2	1	6 28309 24132 2
Al	CMH2B3A	0.62	0.28	mm	76	25	6 28309 24211 4
Zn	CMH2B3Z	1.65	0.75	in	3	1	6 28309 24133 9
Al	CMH2B4A	1.40	0.63	mm	101	25	6 28309 24212 1
Zn	CMH2B4Z	3.30	1.49	in	4	1	6 28309 24134 6
Al	CMH2B5A	2.00	0.90	mm	127	28	6 28309 12859 3
Zn	CMH2B5Z	5.25	2.38	in	5	1.1	6 28309 12012 2
Al	CMH2B6A	3.00	1.35	mm	152	25	6 28309 11954 6
Zn	CMH2B6Z	7.10	3.20	in	6	1	6 28309 24469 9
Al	CMH2B9A	6.70	3.04	mm	228	25	6 28309 12540 0
Zn	CMH2B9Z	16.00	7.25	in	9	1	Please Contact Us
Al	CMH2B11A	10.10	4.60	mm	279	25	6 28309 24578 8
Zn	CMH2B11Z	24.00	10.90	in	11	1	6 28309 24468 2

AVAILABLE IN TWO
INSERT SIZE OPTIONS.
PLEASE SPECIFY HOLE
SIZE: 5/8" TO FIT 1/2" BOLT
OR 1/2" TO FIT 3/8" BOLT



CMH2B2 CMH2B3 CMH2B4 CMH2B5 CMH2B6 CMH2B9 CMH2B11

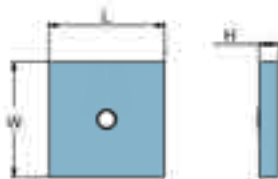

	PID	LB	KG		L	W	H	UPC
Al	CMH1B6GA	3.70	1.68	mm	152	152	25	6 28309 11930 0
Zn	CMH1B6GZ	8.10	3.67	in	6	6	1	6 28309 12619 3

AVAILABLE IN TWO INSERT SIZE OPTIONS. PLEASE SPECIFY HOLE SIZE:
5/8" TO FIT 1/2" BOLT OR 1/2" TO FIT 3/8" BOLT

OLYMPIC™ DRIVE ANODES

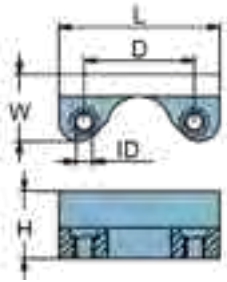

	PID	LB	KG		L	W	H	D	ID	UPC
Al	CMOLYA	2.11	0.96	mm	158	66	66	108	16	6 28309 24224 4
Zn	CMOLY	4.95	2.24	in	6.2	2.6	2.6	4.25	0.62	6 28309 12014 6
Al	CMOLY1HA	2.65	1.20	mm	158	79	66	108	16	6 28309 10763 5
Zn	CMOLY1HZ	6.30	2.86	in	6.2	3.1	2.6	4.25	0.62	6 28309 10764 2

PLATFORM/STANDOFF ANODES

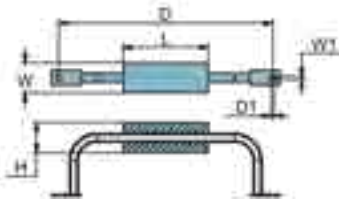

	PID	LB	KG		L	W	W1	H	D	D1	UPC
Al	TYPE1	211.00	96.00	mm	1120	200	22	200	1970	18	6 28309 24158 2
				in	44	7.87	0.87	7.87	77.6	0.71	
Zn	TYPE2	105.60	48.00	mm	560	200	22	200	1410	18	6 28309 24159 9
				in	22	7.87	0.87	7.87	55.5	0.71	

*PLEASE ENQUIRE ABOUT CUSTOM SIZES.

HEATER TREATER ANODES



	PID	LB	KG		L	OD	THD	UPC
Al	CMHT321A	16.00	7.25	mm	541	76	5/8-18	6 28309 12530 1
Zn	CMHT321Z	38.00	17.23	in	21.5	3	UNF	6 28309 11951 5
Al	CMHT330A	23.50	10.70	mm	775	76	3/4-10	6 28309 11805 1
Zn	CMHT330Z	56.00	25.40	in	30	3	UNC	6 28309 12848 7

Type 321 has male 5/8 NF thread on one end and female 5/8 NF thread on the other end. Type 330 has 3/4 NC female thread at both ends. Different length of rods are available on request.

PROP NUT ANODES

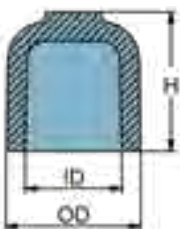

	PID	LB	KG		ID	OD	H	UPC
Al	CMPN01A	1.54	0.70	mm	63	85	92	6 28309 12382 6
Zn	CMPN01Z	4.00	1.80	in	2.5	3.37	3.62	6 28309 11476 3
Al	CMPN02A	2.06	0.93	mm	73	95	101	6 28309 12383 3
Zn	CMPN02Z	5.34	2.42	in	2.87	3.75	4	6 28309 11477 0
Al	CMPN03A	2.29	1.04	mm	82	104	101	6 28309 12384 0
Zn	CMPN03Z	6.00	2.70	in	3.25	4.12	4	6 28309 11478 7
Al	CMPN04A	3.00	1.36	mm	95	117	114	6 28309 12385 7
Zn	CMPN04Z	7.50	3.40	in	3.75	4.62	4.5	6 28309 11479 4
Al	CMPN05A	4.21	1.91	mm	107	133	127	6 28309 12386 4
Zn	CMPN05Z	11.00	5.00	in	4.25	5.25	5	6 28309 11480 0

Choose
Aluminum

Al premium
SALT AND BRACKISH WATER

Anodes for
salt and brackish
water and
Magnesium

Mg fresh
FRESH WATER ONLY
for freshwater.

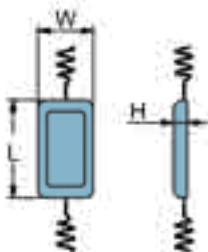
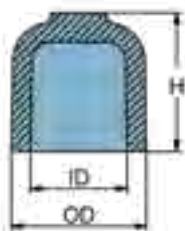

*AVAILABLE WITH
OR



WITHOUT
WIRES

PROP NUT ANODES

	PID	LB	KG		ID	OD	H	UPC
Al	CMPN06A	4.80	2.20	mm	117	142	139	28309 12387 1
Zn	CMPN06Z	11.50	5.20	in	4.62	5.62	5.5	28309 11481 7
Al	CMPN07A	5.50	2.50	mm	127	152	152	28309 12388 8
Zn	CMPN07Z	15.3	6.94	in	5	6	6	28309 11482 4
Al	CMPN08A	7.00	3.20	mm	139	168	161	28309 12389 5
Zn	CMPN08Z	17.86	8.10	in	5.5	6.62	6.37	28309 11483 1
Al	CMPN09A	8.20	3.70	mm	152	180	171	28309 12390 1
Zn	CMPN09Z	20.28	9.20	in	6	7.12	6.75	28309 11484 8
Al	CMPN10A	11.24	5.10	mm	165	196	177	28309 12101 3
Zn	CMPN10Z	29.14	13.22	in	6.5	7.75	7	28309 11485 5
Al	CMPN11A	11.80	5.35	mm	177	206	206	28309 12391 8
Zn	CMPN11Z	28.00	12.70	in	7	8.12	8.12	28309 11486 2
Al	CMPN12A	16.31	7.40	mm	190	222	228	28309 12392 5
Zn	CMPN12Z	42.29	19.18	in	7.5	8.75	9	28309 11487 9
Al	CMPN13A	0.804	0.365	mm	50.04	70.10	71.88	28309 12393 2
Zn	CMPN13Z	2.094	0.950	in	1.97	2.76	2.83	28309 11488 6
Al	CMPN13BA	1.10	0.50	mm	57	76	76	28309 24241 1
Zn	CMPN13BZ	2.50	1.15	in	2.25	3	3	28309 24142 1
Al	CMPN14A	0.932	0.423	mm	55.12	74.93	73.91	28309 12397 0
Zn	CMPN14Z	2.425	1.100	in	2.17	2.95	2.91	28309 11489 3

PLATE STOCK ANODES

	PID	LB	KG		L	W	H	UPC
Al	CMPMA/CMPMWA	0.78	0.35	mm	114	64	17	28309 24363 0
Zn	CMPMZ/CMPMWZ	2.00	0.90	in	4.5	2.5	0.65	28309 11265 3
Al	CMPNA/CMPNWA	1.26	0.57	mm	152	76	19	28309 10871 7
Zn	CMPNZ/CMPNWZ	3.25	1.48	in	6	3	0.75	28309 11267 7
Al	CMPOA/CMPOWA	1.70	0.77	mm	152	102	19	28309 24247 3
Zn	CMPOZ/CMPOWZ	4.38	1.99	in	6	4	0.75	28309 11269 1
Al	CMPPA/CMPPWA	3.59	1.63	mm	229	127	21	28309 24248 0
Zn	CMPPZ/CMPPWZ	9.25	4.20	in	9	5	0.8	28309 11272 1
Al	CMP0515115A	0.84	0.38	mm	288	38	13	28309 24230 5
Zn	CMP0515115Z	2.21	1.00	in	11.5	1.5	0.5	28309 11973 7
Al	CMP051512A	0.93	0.42	mm	305	38	13	28309 24231 2
Zn	CMP051512Z	2.30	1.04	in	12	1.5	0.5	28309 11237 0
Al	CMP05204A	0.41	0.18	mm	100	50	13	28309 24232 9
Zn	CMP05204Z	1.020	0.463	in	4	2	0.5	28309 11947 8
Al	CMP05212A	1.17	0.53	mm	305	50	13	28309 24233 6
Zn	CMP05212Z	3.07	1.39	in	12	2	0.5	28309 11948 5
Al	CMP05224A	2.337	1.060	mm	710	50	13	28309 24234 3
Zn	CMP05224Z	6.14	2.79	in	24	2	0.5	28309 11418 3
Al	CMP05303A	0.429	0.195	mm	76	76	13	28309 11443 5
Zn	CMP05303Z	1.122	0.509	in	3	3	0.5	28309 11240 0

Martyr®
MISCELLANEOUS ANODES

PLATE STOCK ANODES



	PID	LB	KG		L	W	H	UPC
Al	CMP05306A	0.90	0.41	mm	152	76	13	6 28309 11444 2
Zn	CMP05306Z	2.20	1.00	in	6	3	0.5	6 28309 11242 4
Al	CMP05406A	1.24	0.56	mm	152	100	13	6 28309 24235 0
Zn	CMP05406Z	3.07	1.39	in	6	4	0.5	6 28309 11246 2
Zn	CMP05312Z	4.61	2.10	mm	305	76	13	6 28309 11244 8
				in	12	3	0.5	
Al	CMP05606A	1.90	0.86	mm	152	152	13	6 28309 11445 9
Zn	CMP05606Z	4.80	2.15	in	6	6	0.5	6 28309 11247 9
Al	CMP05612A	3.80	1.72	mm	305	152	13	6 28309 12035 1
Zn	CMP05612Z	9.50	4.31	in	12	6	0.5	6 28309 11249 3
Al	CMP075106A	0.46	0.21	mm	152	25	19	6 28309 24237 4
Zn	CMP075106Z	1.15	0.52	in	6	1	0.75	6 28309 12020 7
Al	CMP075303A	0.70	0.32	mm	76	76	19	6 28309 11931 7
Zn	CMP075303Z	1.75	0.79	in	3	3	0.75	6 28309 11251 6
Al	CMP075306A	1.212	0.55	mm	152	76	19	6 28309 11447 3
Zn	CMP075306Z	3.50	1.59	in	6	3	0.75	6 28309 11252 3
Al	CMP075606A	2.71	1.23	mm	152	152	19	6 28309 12009 2
Zn	CMP075606Z	6.87	3.11	in	6	6	0.75	6 28309 11254 7
Al	CMP075612A	5.60	2.54	mm	305	152	19	6 28309 12010 8
Zn	CMP075612Z	14.00	6.35	in	12	6	0.75	6 28309 11255 4
Al	CMP1206A	1.144	0.519	mm	152	50	25	6 28309 12409 0
Zn	CMP1206Z	2.983	1.353	in	6	2	1	6 28309 11256 1
Al	CMP1303A	0.90	0.41	mm	76	76	25	6 28309 11449 7
Zn	CMP1303Z	2.25	1.01	in	3	3	1	6 28309 11257 8
Al	CMP1304A	1.091	0.495	mm	104	76	25	6 28309 12554 7
Zn	CMP1304Z	2.841	1.289	in	4	3	1	6 28309 12165 5
Al	CMP1306A	1.80	0.82	mm	152	76	25	6 28309 11450 3
Zn	CMP1306Z	4.50	2.04	in	6	3	1	6 28309 11259 2
Al	CMP1406A	2.44	1.10	mm	152	104	25	6 28309 12555 4
Zn	CMP1406Z	6.11	2.77	in	6	4	1	6 28309 11260 8
Al	CMP1606A	3.60	1.63	mm	152	152	25	6 28309 12007 8
Zn	CMP1606Z	9.00	4.08	in	6	6	1	6 28309 11261 5
Al	CMP1612A	7.20	3.27	mm	305	152	25	6 28309 12008 5
Zn	CMP1612Z	18.00	8.16	in	12	6	1	6 28309 11262 2
Al	CMP075406A	1.84	0.84	mm	152	104	20	6 28309 12405 2
Zn	CMP075406Z	4.60	2.09	in	6	4	0.8	6 28309 12102 0
Al	CMP11504A	0.553	0.251	mm	104	38	25	6 28309 12407 6
Zn	CMP11504Z	1.437	0.652	in	4	1.5	1	6 28309 12169 3
Al	CMP11505A	0.659	0.299	mm	125	38	25	6 28309 12408 3
Zn	CMP11505Z	1.717	0.779	in	5	1.5	1	6 28309 12203 4
Al	CMP1312A	3.62	1.642	mm	304	76	25	6 28309 15940 5
				in	12	3	1	

MISCELLANEOUS ANODES

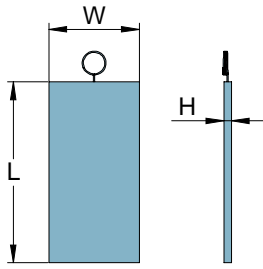

***AVAILABLE WITH
OR**



**WITHOUT
WIRES**

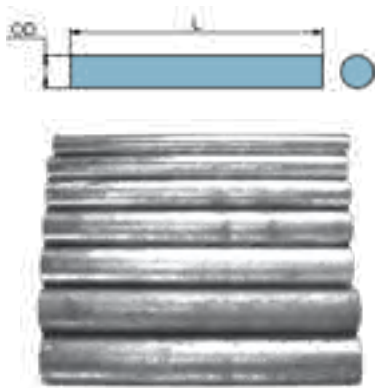

PLATE STOCK ANODES

	PID	LB	KG		L	W	H	UPC
Al	CMP166A	3.52	1.60	mm	152	152	25	6 28309 12556 1
Zn	CMP166Z	8.80	3.99	in	6	6	1	6 28309 12236 2
Al	CMP631A	1.76	0.80	mm	152	76	25	6 28309 24240 4
Zn	CMP631Z	4.41	2.00	in	6	3	1	6 28309 12193 8
Zn	CMP05306WZ	2.30	1.04	mm	152	76	13	6 28309 11242 4
				in	6	3	0.5	
Zn	CMP05606WZ	4.61	2.10	mm	152	152	13	6 28309 11247 9
				in	6	6	0.5	
Al	CMP05612WA	3.68	1.67	mm	305	152	13	6 28309 24236 7
Zn	CMP05612WZ	9.20	4.19	in	12	6	0.5	6 28309 11250 9
Al	CMP075306WA	1.38	0.63	mm	152	76	19	6 28309 24238 1
Zn	CMP075306WZ	3.46	1.57	in	6	3	0.75	6 28309 11253 0
Al	CMP075406WA	1.84	0.84	mm	152	101	20	6 28309 24239 8
Zn	CMP075406WZ	4.61	2.10	in	6	4	0.8	6 28309 12406 9

ROD STOCK ANODES

	PID	LB	KG		L	OD	UPC
Zn	CMR0512Z	0.60	0.27	mm	305	13	6 28309 12173 0
				in	12	0.5	
Zn	CMR062512Z	0.96	0.43	mm	305	16	6 28309 12234 8
				in	12	0.62	
Zn	CMR07512Z	1.35	0.61	mm	305	19	6 28309 12207 2
				in	12	0.75	
Zn	CMR1524Z	10.80	4.90	mm	610	38	6 28309 11950 8
				in	24	1.5	
Zn	CMR224Z	19.30	8.76	mm	610	50	6 28309 11427 5
				in	24	2	
Zn	CMR324Z	43.20	19.60	mm	610	76	6 28309 11428 2
				in	24	3	
Zn	CMR037536Z	1.01	0.46	mm	914	9	6 28309 12160 0
				in	36	0.37	
Zn	CMR0536Z	1.80	0.82	mm	914	13	6 28309 12157 0
				in	36	0.5	
Zn	CMR062539Z	3.14	1.42	mm	1000	16	6 28309 12158 7
				in	39	0.62	
Zn	CMR07539Z	4.43	2.01	mm	1000	19	6 28309 12161 7
				in	39	0.75	
Zn	CMR087539Z	5.93	2.69	mm	1000	22	6 28309 12162 4
				in	39	0.87	
Zn	CMR139Z	7.93	3.60	mm	1000	25	6 28309 12156 3
				in	39	1	
Zn	CMR12539Z	12.55	5.70	mm	1000	32	6 28309 12159 4
				in	39	1.25	

FERNSTRUM KEEL ANODES

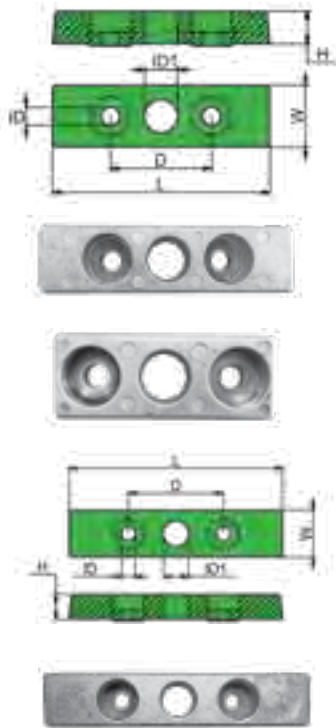

	PID	LB	KG		D	ID1	ID	L	W	H	UPC
Al	CM1874SA	1.29	0.58	mm	82.55	26.67	14.28	177.8	50.8	26.98	6 28309 25577 0
Mg	CM1874SM	0.93	0.42	in	3.25	1.05	0.56	7	2	1.06	6 28309 25581 7
Zn	CM1874SZ	2.85	1.29								6 28309 25573 2
Al	CM2624SA	0.77	0.35	mm	82.55	26.67	14.28	127	50.8	20.3	6 28309 25578 7
Mg	CM2624SM	0.61	0.27	in	3.25	1.05	0.56	5	2	0.8	6 28309 25582 4
Zn	CM2624SZ	1.51	0.68								6 28309 25574 9

	PID	LB	KG		D	ID	ID1	L	W	H	UPC
Al	CM2874SA	1.68	0.76	mm	101.6	14.28	26.67	228.6	50.8	26.98	6 28309 25579 4
Mg	CM2874SM	1.18	0.53	in	4	0.56	1.05	9	2	1.06	6 28309 25583 1
Zn	CM2874SZ	3.87	1.75								6 28309 25575 6

WALTER KEEL ANODES

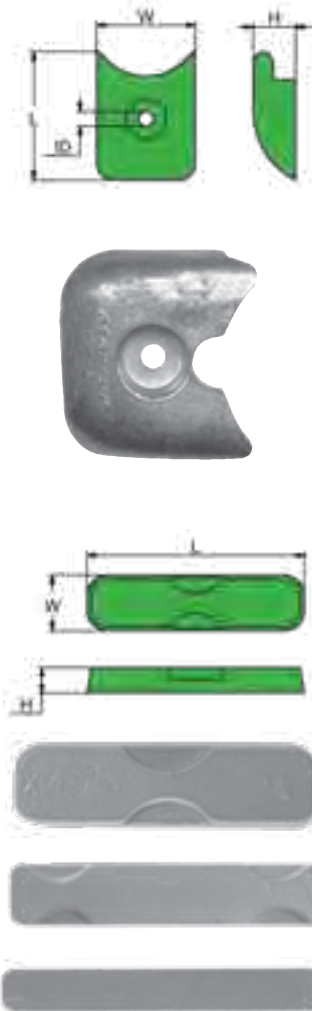

	PID	LB	KG		L	W	H	ID	UPC
Al	CMKK1A	0.41	0.19	mm	80.77	65	27.68	9.62	6 28309 11495 4
Mg	CMKK1M	0.264	0.12	in	3.18	2.57	1.09	0.38	6 28309 24340 1
Zn	CMKK1Z	1.058	0.48						6 28309 19173 3
Al	CMKK2A	0.48	0.22	mm	82.80	83.31	29	9.62	6 28309 19174 0
Mg	CMKK2M	0.286	0.13	in	3.26	3.28	1.12	0.38	6 28309 24341 8
Zn	CMKK2Z	1.21	0.55						6 28309 11381 0
Al	CMKK3A	1.21	0.55	mm	137	89	40.13	9	6 28309 19175 7
Mg	CMKK3M	0.77	0.35	in	5.4	3.5	1.58	0.35	6 28309 24342 5
Zn	CMKK3Z	3.18	1.44						6 28309 11473 2

	PID	LB	KG		L	W	H	UPC
Al	CMX453A	0.092	0.042	mm	86	22	10	6 28309 19176 4
Mg	CMX453M	0.057	0.026	in	3.37	0.87	0.37	6 28309 24395 1
Zn	CMX453Z	0.242	0.110					6 28309 11190 8
Al	CMX473A	0.289	0.131	mm	172	32	10	6 28309 19177 1
Mg	CMX473M	0.180	0.082	in	6.75	1.25	0.37	6 28309 24396 8
Zn	CMX473Z	0.736	0.334					6 28309 11191 5
Al	CMX58A	0.216	0.098	mm	159	22	12	6 28309 19178 8
Mg	CMX58M	0.136	0.062	in	6.25	0.87	0.5	6 28309 24397 5
Zn	CMX58Z	0.562	0.255					6 28309 11192 2

KEEL ANODES

COMMERCIAL
HULL ANODES
(SPECIAL ORDERS)

HULL ANODES (SPECIAL ORDERS)

BOLT HOLES CAN BE ADDED ON STRAPS AS REQUIRED



	PID	LB	KG		L	W	W1	H	D	UPC
Zn	JDP320220Z	1.28	0.58	mm	75	70	14	20	6	6 28309 23990 9
				in	3	2.8	0.55	0.8	0.24	

BOLT-ON

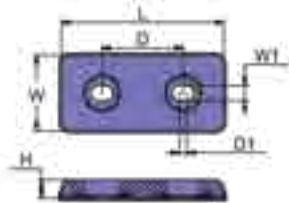

	PID	LB	KG		L	W	W1	H	D	D1	UPC
Zn	JDP320221Z	2.35	1.07	mm	150	70	14	18	75	6	6 28309 23991 6
				in	5.9	2.8	0.55	0.7	2.95	0.24	

BOLT-ON

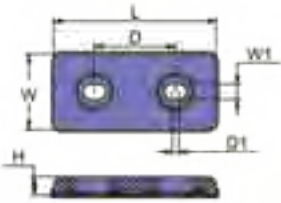

	PID	LB	KG		L	W	W1	H	D	D1	UPC
Al	JDP320222A	1.18	0.54	mm	150	70	14	20	75	6	6 28309 24031 8
Zn	JDP320222Z	2.68	1.22	in	5.9	2.8	0.55	0.8	2.95	0.24	

BOLT-ON

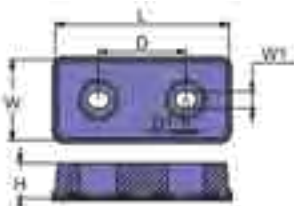

	PID	LB	KG		L	W	W1	H	D	D1	UPC
Al	JDB2GBA	1.30	0.60	mm	150	75	14	25	75	4	6 28309 24009 7
Zn	JDB2GBZ	3.20	1.50	in	2.9	3	0.55	1	2.95	0.16	

BOLT-ON

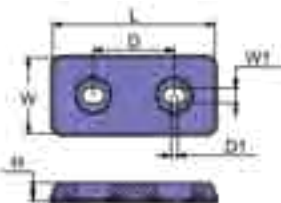

	PID	LB	KG		L	W	W1	H	D	D1	UPC
Zn	JDP320223Z	3.28	1.49	mm	150	70	14	25	75	6	6 28309 23993 0
				in	5.9	2.8	0.55	1	2.95	0.24	

BOLT-ON



HULL ANODES (SPECIAL ORDERS)

HULL ANODES (SPECIAL ORDERS)

BOLT HOLES CAN BE ADDED ON STRAPS AS REQUIRED

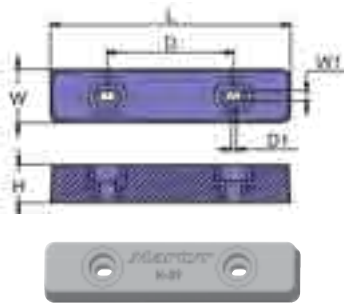

	PID	LB	KG		L	W	W1	H	D	D1	UPC
Al	JDH39SBA	1.32	0.60	mm	190	42	8	30	100	4	6 28309 24020 2
Zn	JDH39SBZ	3.30	1.50	in	7.5	1.62	0.31	1.19	3.94	0.16	6 28309 17199 5

BOLT-ON

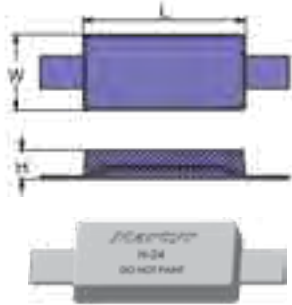

	PID	LB	KG		L	W	H	UPC
Al	JDH24GA	2.00	0.90	mm	150	70	27	6 28309 17356 2
Zn	JDH24GZ	4.20	1.90	in	5.9	2.76	1.1	6 28309 17196 4

BOLT-ON

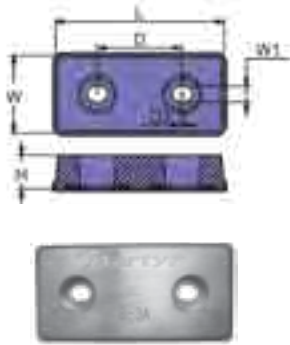

	PID	LB	KG		L	W	W1	H	D	D1	UPC
Zn	JDP320219Z	4.30	1.95	mm	200	100	14	15	110	6	6 28309 23989 3
				in	7.87	3.94	0.55	0.59	4.33	0.24	

COMBO

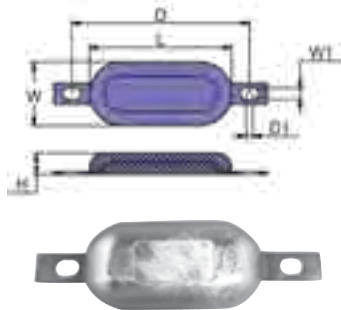

	PID	LB	KG		L	W	W1	H	D	D1	UPC
Al	JDH48GA	1.90	0.90	mm	200	80	16	30	200	10	6 28309 17372 2
Zn	JDH48GZ	4.40	2.00	in	7.87	3.15	0.63	1.18	7.87	0.39	6 28309 17201 5

BOLT-ON

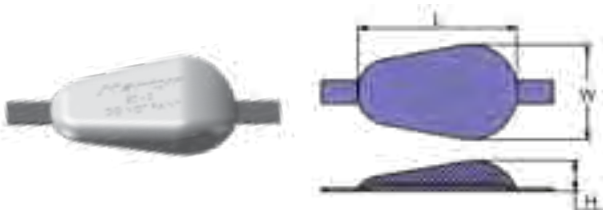

	PID	LB	KG		L	W	H	UPC
Al	JDDM20A	2.00	0.90	mm	169	100	32	6 28309 21525 5
Zn	JDDM20Z	4.85	2.20	in	6.7	4	1.26	6 28309 17167 4

BOLT-ON

HULL ANODES (SPECIAL ORDERS)

BOLT HOLES CAN BE ADDED ON STRAPS AS REQUIRED



	PID	LB	KG		L	W	W1	H	D	D1	UPC
Al	JDB3GBA	2.30	1.00	mm	200	100	14	20	110	4	6 28309 17323 4
Zn	JDB3GBZ	5.50	2.50	in	7.87	3.94	0.55	0.8	4.33	0.16	6 28309 17152 0

BOLT-ON



	PID	LB	KG		L	W	W1	H	D	D1	UPC
Zn	JDP320224Z	5.64	2.56	mm	200	100	14	20	110	6	6 28309 23994 7
				in	7.87	3.94	0.55	0.8	4.33	0.24	

BOLT-ON

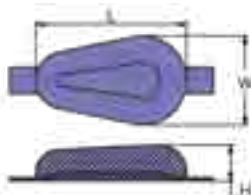

	PID	LB	KG		L	W	H	UPC
Al	JDDM28GBA	2.90	1.30	mm	170	100	40	6 28309 24012 7
Zn	JDDM28GBZ	6.60	3.00	in	6.7	3.9	1.57	6 28309 17171 1

WELD-ON



	PID	LB	KG		L	W	W1	H	D	D1	UPC
Al	JDH62GBA	2.90	1.30	mm	200	100	14	25	110	4	6 28309 17387 6
Zn	JDH62GBZ	6.60	3.00	in	7.87	3.94	0.55	1	4.33	0.16	6 28309 17213 8

BOLT-ON

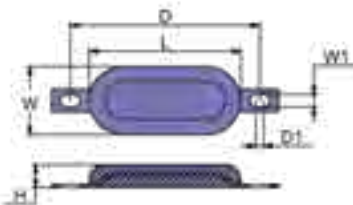

	PID	LB	KG		L	W	W1	H	D	D1	UPC
Al	JDH49GBA	2.20	1.00	mm	200	90	16	30	250	10	6 28309 17373 9
Zn	JDH49GBZ	6.60	3.00	in	7.87	3.54	0.63	1.18	9.84	0.39	6 28309 17202 2

COMBO



HULL ANODES (SPECIAL ORDERS)

Choose
Aluminum

Al premium
SALT AND BRACKISH WATER

Anodes for
salt and brackish
water and
Magnesium

Mg fresh
FRESH WATER ONLY
for freshwater.

HULL ANODES (SPECIAL ORDERS)

BOLT HOLES CAN BE ADDED ON STRAPS AS REQUIRED

	PID	LB	KG		L	W	W1	H	D	D1	UPC
Al	JDH56GBA	3.10	1.40	mm	200	100	14	25	110	4	6 28309 17378 4
Zn	JDH56GBZ	6.80	3.10	in	7.87	3.94	0.55	1	4.33	0.16	6 28309 17379 1

BOLT-ON



	PID	LB	KG		L	W	H	UPC			
Al	JDH10GA	3.10	1.40	mm	180	70	40	6 28309 17343 2			
Zn	JDH10GZ	7.50	3.40	in	7.1	2.76	1.57	6 28309 17182 7			

WELD-ON

	PID	LB	KG		L	W	W1	H	D	D1	UPC
Al	JDB4GBA	3.30	1.50	mm	200	100	14	30	110	4	6 28309 24010 3
Zn	JDB4GBZ	7.90	3.60	in	7.87	3.94	0.55	1.18	4.33	0.16	6 28309 23968 8

WELD-ON

	PID	LB	KG		L	W	W1	H	D	D1	UPC
Al	JDH55GBA	3.70	1.70	mm	200	70	16	50	250	10	6 28309 17377 7
Zn	JDH55GBZ	9.10	4.20	in	7.87	2.75	0.63	1.97	9.84	0.39	6 28309 23984 8

BOLT-ON

	PID	LB	KG		L	W	H	UPC			
Al	JDS4GA	4.20	1.90	mm	200	100	30	6 28309 17411 8			
Zn	JDS4GZ	9.20	4.20	in	7.87	3.94	1.18	6 28309 23995 4			

WELD-ON

Martyr
HULL ANODES (SPECIAL ORDERS)

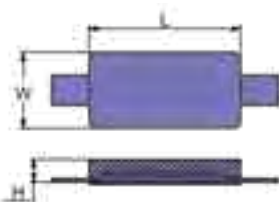
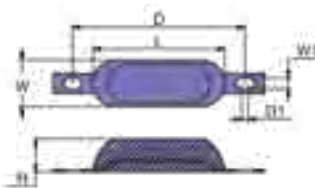
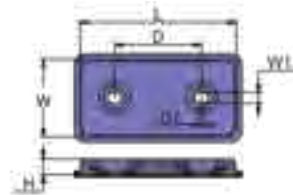
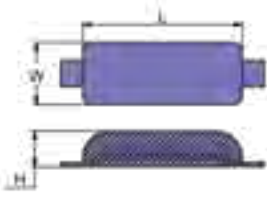

HULL ANODES (SPECIAL ORDERS)

BOLT HOLES CAN BE ADDED ON STRAPS AS REQUIRED

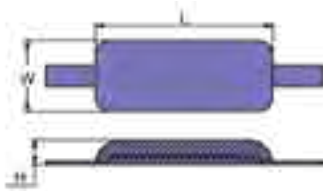

	PID	LB	KG		L	W	H	UPC	
Al	JDGBZH02A	5.07	2.30	mm	250	100	35	6	28309 17339 5
Zn	JDGBZH02Z	11.90	5.40	in	9.8	4	1.38	6	28309 17180 3

WELD-ON

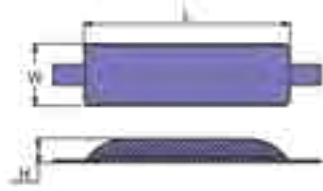

	PID	LB	KG		L	W	H	UPC	
Al	JDDM45A	5.00	2.30	mm	300	90	35	6	28309 24013 4
Zn	JDDM45Z	13.00	5.90	in	11.8	3.54	1.38	6	28309 17172 8

WELD-ON

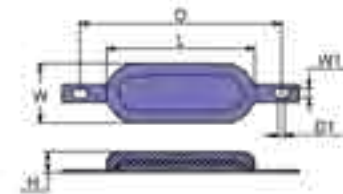

	PID	LB	KG		L	W	W1	H	D	D1	UPC	
Al	JDH50GBA	4.62	2.10	mm	250	100	16	35	340	10	6	28309 24023 3
Zn	JDH50GBZ	11.00	5.00	in	9.8	4	0.63	1.38	13.4	0.39	6	28309 17204 6

COMBO

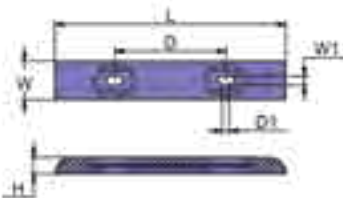

	PID	LB	KG		L	W	W1	H	D	D1	UPC	
Al	JDH53GBA	5.90	2.70	mm	457	76	18	33	220	14	6	28309 24025 7
Zn	JDH53GBZ	14.50	6.60	in	18	3	0.7	1.3	8.66	0.55	6	28309 17207 7

BOLT-ON

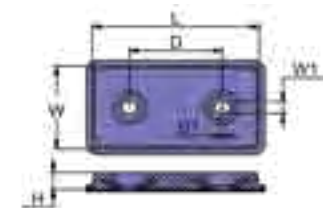

	PID	LB	KG		L	W	W1	H	D	D1	UPC	
Al	JDB8GBA	6.40	2.90	mm	300	150	18	25	160	4	6	28309 17326 5
Zn	JDB8GBZ	16.10	7.30	in	11.8	5.9	0.7	1	6.3	0.16	6	28309 17156 8

BOLT-ON



HULL ANODES (SPECIAL ORDERS)

HULL ANODES (SPECIAL ORDERS)

BOLT HOLES CAN BE ADDED ON STRAPS AS REQUIRED

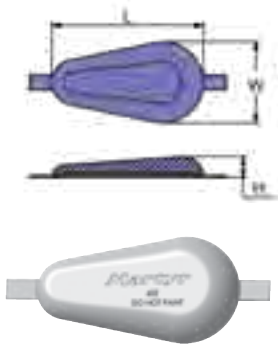

	PID	LB	KG		L	W	H	UPC
Al	JDDM60GA	6.38	2.90	mm	300	160	42	6 28309 17336 4
Zn	JDDM60GZ	16.50	7.50	in	11.8	6.3	1.63	6 28309 17173 5

WELD-ON



	PID	LB	KG		L	W	W1	H	D	D1	UPC
Al	JDH61GBA	7.0	3.2	mm	300	100	10	40	340	10	6 28309 17386 9
Zn	JDH61GBZ	17.2	7.8	in	11.8	3.94	0.39	1.57	14	0.39	6 28309 17211 4

BOLT-ON

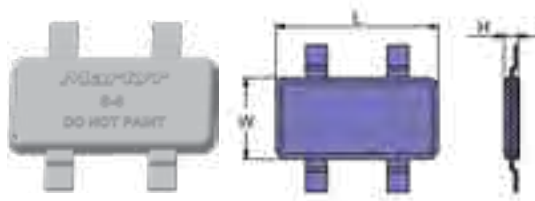

	PID	LB	KG		L	W	H	UPC
Al	JDS8GA	7.70	3.50	mm	300	150	25	6 28309 24034 9
Zn	JDS8GZ	17.60	8.00	in	11.8	5.9	1	6 28309 17290 9

WELD-ON



	PID	LB	KG		L	W	W1	H	D	D1	UPC
Al	JDH63GBA	7.00	3.20	mm	300	150	18	30	160	4	6 28309 17585 6
Zn	JDH63GBZ	17.60	8.00	in	11.8	5.9	0.7	1.18	6.3	0.16	6 28309 17214 5

BOLT-ON

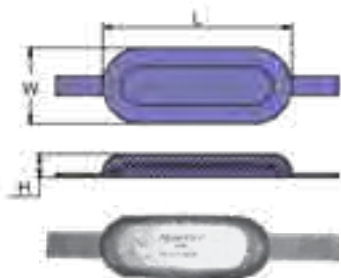

	PID	LB	KG		L	W	H	UPC
Al	JDH51GA	7.70	3.50	mm	300	120	37	6 28309 17375 3
Zn	JDH51GZ	17.60	8.00	in	11.8	4.7	1.46	6 28309 17205 3

WELD-ON

HULL ANODES (SPECIAL ORDERS)

BOLT HOLES CAN BE ADDED ON STRAPS AS REQUIRED



	PID	LB	KG		L	W	W1	H	D	D1	UPC
Al	JDB9GBA	7.00	3.20	mm	300	150	18	30	160	22	6 28309 24011 0
Zn	JDB9GBZ	18.30	8.30	in	11.8	5.9	0.7	1.18	6.3	0.87	6 28309 17157 5

BOLT-ON

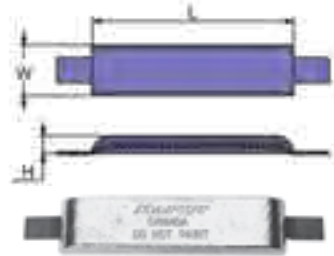

	PID	LB	KG		L	W	H	UPC
Al	JDH01A	8.80	4.00	mm	400	100	35	6 28309 24016 5
Zn	JDH01Z	19.50	9.00	in	15.75	4	1.38	6 28309 23972 5

WELD-ON

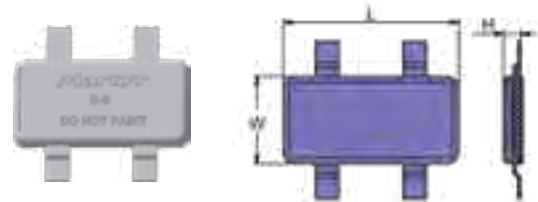

	PID	LB	KG		L	W	H	UPC
Al	JDS9GA	8.80	4.00	mm	300	150	30	6 28309 24036 3
Zn	JDS9GZ	19.80	9.00	in	11.8	5.9	1.18	6 28309 17291 6

WELD-ON

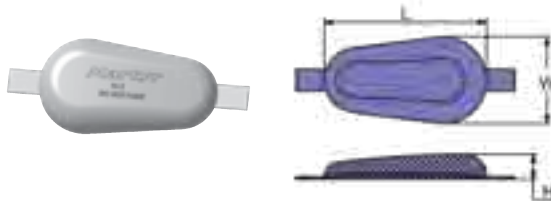

	PID	LB	KG		L	W	H	UPC
Al	JDDM96GA	9.24	4.20	mm	300	150	45	6 28309 24014 1
Zn	JDDM96GZ	22.00	10.00	in	11.8	5.9	1.77	6 28309 17174 2

WELD-ON



	PID	LB	KG		L	W	W1	H	D	D1	UPC
Al	JDH47GBA	10.30	4.70	mm	500	60	18	50	660	12	6 28309 24022 6
Zn	JDH47GBZ	23.50	10.70	in	19.7	2.36	0.7	1.97	26	0.47	6 28309 23983 1

COMBO



	PID	LB	KG		L	W	H	UPC
Al	JDH7GA	9.90	4.50	mm	400	100	40	6 28309 17391 3
Zn	JDH7GZ	23.50	10.70	in	15.7	3.94	1.57	6 28309 17218 3

WELD-ON

HULL ANODES (SPECIAL ORDERS)

Choose
Aluminum

Al premium
SALT AND BRACKISH WATER

Anodes for
salt and brackish
water and
Magnesium

Mg fresh
FRESH WATER ONLY
for freshwater.

HULL ANODES (SPECIAL ORDERS)

BOLT HOLES CAN BE ADDED ON STRAPS AS REQUIRED

	PID	LB	KG		L	W	W1	H	D	D1	UPC
Al	JDH21GBA	9.2	4.2	mm	300	150	18	40	160	8	6 28309 17350 0
Zn	JDH21GBZ	24.2	11.0	in	11.8	5.9	0.72	1.57	6.3	0.32	6 28309 17188 9

BOLT-ON

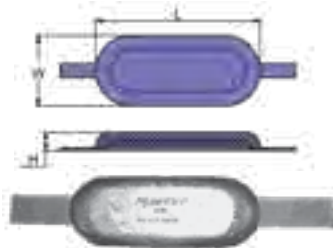
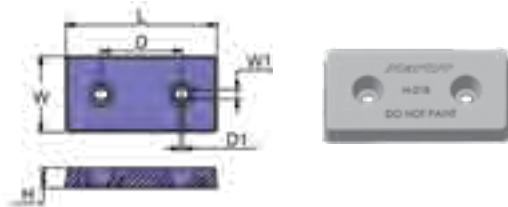

	PID	LB	KG		L	W	H	UPC
Al	JDH52GA	10.80	4.90	mm	350	150	39	6 28309 24024 0
Zn	JDH52GZ	26.40	12.00	in	13.8	5.9	1.5	6 28309 17206 0

WELD-ON

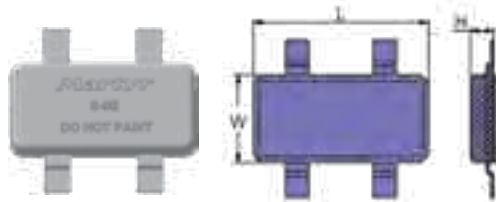

	PID	LB	KG		L	W	H	UPC
Al	JDS9EGA	11.00	5.00	mm	300	150	40	6 28309 24035 6
Zn	JDS9EGZ	26.40	12.00	in	11.8	5.9	1.57	6 28309 17292 3

WELD-ON

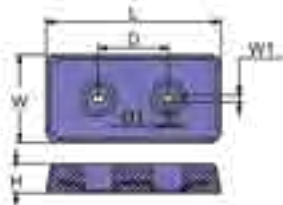

	PID	LB	KG		L	W	W1	H	D	D1	UPC
Al	JDH13GBA	10.8	4.9	mm	300	150	12	50	120	8	6 28309 24017 2
Zn	JDH13GBZ	26.4	12.0	in	11.8	5.9	0.47	2	4.72	0.32	6 28309 17760 7

BOLT-ON

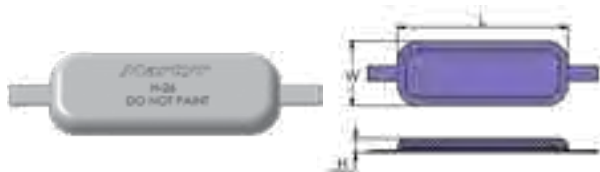

	PID	LB	KG		L	W	H	UPC
Al	JDH26GA	11.00	5.00	mm	400	150	33	6 28309 17360 9
Zn	JDH26GZ	27.10	12.30	in	15.7	5.9	1.3	6 28309 23976 3

WELD-ON

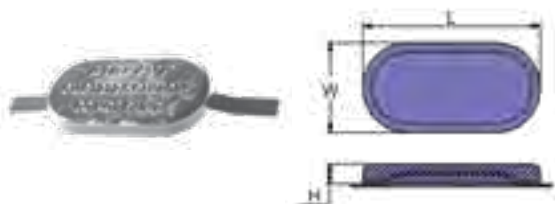

	PID	LB	KG		L	W	H	UPC
Al	JDH36GA	11.20	5.10	mm	305	152	34	6 28309 17364 7
				in	12	6	1.34	

WELD-ON

Martyr
HULL ANODES (SPECIAL ORDERS)

HULL ANODES (SPECIAL ORDERS)

BOLT HOLES CAN BE ADDED ON STRAPS AS REQUIRED

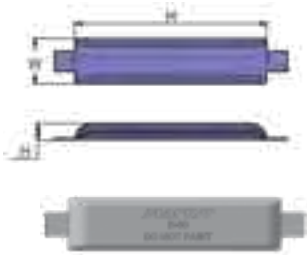

	PID	LB	KG		L	W	H	UPC
Al	JDH60GA	11.90	5.40	mm	465	110	40	6 28309 24026 4
Zn	JDH60GZ	27.50	12.50	in	18.3	4.33	1.57	6 28309 17210 7

WELD-ON

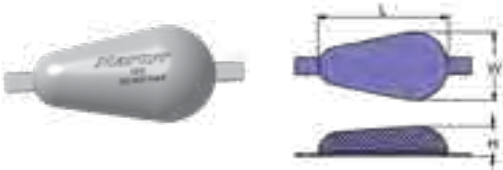

	PID	LB	KG		L	W	H	UPC
Al	JDDM121GA	13.40	6.10	mm	300	160	70	6 28309 17332 6
Zn	JDDM121GZ	27.90	13.00	in	11.8	6.3	2.75	6 28309 17163 6

WELD-ON

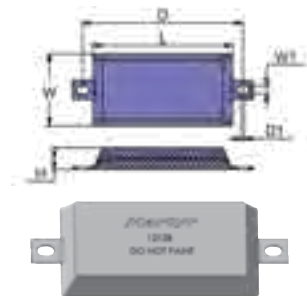

	PID	LB	KG		L	W	W1	H	D	D1	UPC
Al	JDDM121GBA	13.42	6.10	mm	300	152	18	45	345	8	6 28309 17333 3
Zn	JDDM121GBZ	28.60	13.00	in	11.8	6	0.71	1.77	13.58	0.31	6 28309 17164 3

COMBO



	PID	LB	KG		L	W	H	UPC
Al	JDH6GA	12.10	5.50	mm	500	100	40	6 28309 17389 0
Zn	JDH6GZ	28.60	13.00	in	19.7	3.94	1.6	6 28309 17216 9

WELD-ON

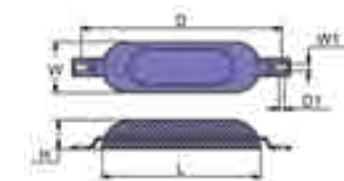

	PID	LB	KG		L	W	W1	H	D	D1	UPC
Al	JDH45GBA	13.42	6.10	mm	352	113	16	65	445	16	6 28309 17370 8
Zn	JDH45GBZ	28.60	13.00	in	13.8	4.45	0.63	2.56	17.5	0.63	6 28309 23982 4

COMBO

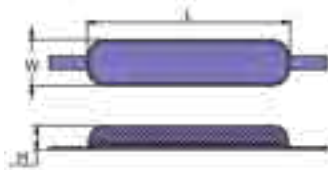

	PID	LB	KG		L	W	H	UPC
Al	JDZD140GA	12.50	5.70	mm	456	102	53	6 28309 24039 4
Zn	JDZD140GZ	30.80	14.00	in	18	4	2.08	6 28309 17306 7

WELD-ON



HULL ANODES (SPECIAL ORDERS)

HULL ANODES (SPECIAL ORDERS)

BOLT HOLES CAN BE ADDED ON STRAPS AS REQUIRED

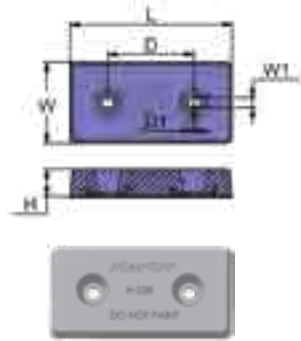

	PID	LB	KG		L	W	W1	H	D	D1	UPC
Al	JDH23BA	12.1	5.5	mm	300	150	18	50	160	8	6 28309 17354 8
Zn	JDH23BZ	31.2	14.2	in	11.8	5.9	0.72	1.96	6.3	0.32	6 28309 17192 6

BOLT-ON

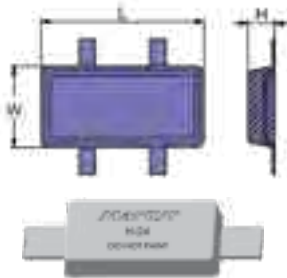

	PID	LB	KG		L	W	H	UPC
Zn	JDH11GZ	31.90	14.50	mm	300	150	50	6 28309 17183 4
				in	11.8	5.9	2	

WELD-ON



	PID	LB	KG		L	W	H	UPC
Al	JDGBZH01A	13.44	6.40	mm	400	100	55	6 28309 17338 8
Zn	JDGBZH01Z	33.00	15.00	in	15.75	3.94	2.17	

WELD-ON

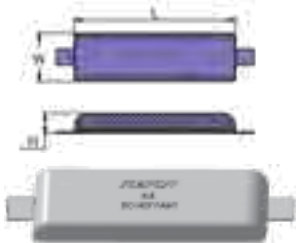

	PID	LB	KG		L	W	H	UPC
Al	JDH5GA	14.10	6.40	mm	400	120	50	6 28309 17384 5
Zn	JDH5GZ	35.00	15.90	in	15.7	4.7	1.97	

WELD-ON



	PID	LB	KG		L	W	H	UPC
Al	JDDM155A	14.50	6.60	mm	520	120	40	6 28309 17334 0
Zn	JDDM155Z	36.60	16.60	in	15.75	4.7	1.6	

WELD-ON

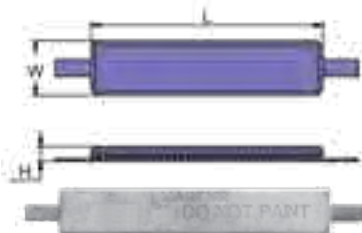

	PID	LB	KG		L	W	H	UPC
Al	JDZD170GA	15.62	7.10	mm	550	130	35	6 28309 24040 0
Zn	JDZD170GZ	37.40	17.00	in	21.7	5.12	1.38	

WELD-ON

Martyr®
HULL ANODES (SPECIAL ORDERS)

HULL ANODES (SPECIAL ORDERS)

BOLT HOLES CAN BE ADDED ON STRAPS AS REQUIRED



	PID	LB	KG		L	W	W1	H	D	D1	UPC
Al	JDH58GBA	15.20	6.90	mm	360	180	18	45	180	8	6 28309 17380 7
Zn	JDH58GBZ	37.80	17.20	in	14.1	7.1	0.72	1.77	7	0.32	6 28309 17381 4

BOLT-ON

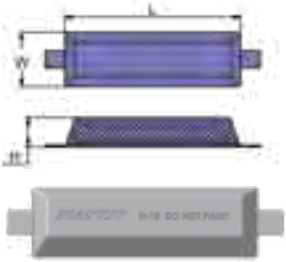

	PID	LB	KG		L	W	H	UPC
Al	JDH15GA	15.40	7.00	mm	400	124	67	6 28309 17346 3
Zn	JDH15GZ	37.80	17.20	in	15.7	4.9	2.64	6 28309 23973 2

WELD-ON

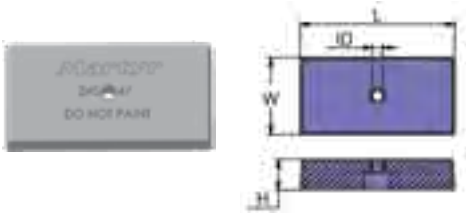

	PID	LB	KG		L	W	H	ID	UPC
Al	JDH37SA	15.40	7.00	mm	305	152	60	20	6 28309 17367 8
Zn	JDH37SZ	40.50	18.40	in	12	6	2.36	0.79	6 28309 23980 0

BOLT-ON

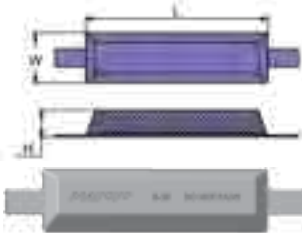

	PID	LB	KG		L	W	H	UPC
Al	JDH25SA	19.80	9.00	mm	450	124	67	6 28309 17359 3
Zn	JDH25SZ	42.90	19.50	in	17.7	4.88	2.64	6 28309 17197 1

WELD-ON



	PID	LB	KG		L	W	W1	H	D	D1	UPC
Al	JDH54GBA	17.90	8.10	mm	540	130	22	53	340	4	6 28309 17376 0
Zn	JDH54GBZ	44.00	20.00	in	21.26	5.12	0.87	2.08	13.4	0.16	6 28309 17208 4

BOLT-ON

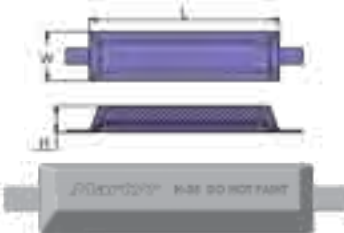

	PID	LB	KG		L	W	H	UPC
Al	JDH35GA	18.70	8.50	mm	480	124	67	6 28309 17363 0
Zn	JDH35GZ	45.50	20.70	in	18.9	4.88	2.64	6 28309 23979 4

WELD-ON

HULL ANODES (SPECIAL ORDERS)

Choose
Aluminum

Al premium
SALT AND BRACKISH WATER

Anodes for
salt and brackish
water and
Magnesium

Mg fresh
FRESH WATER ONLY
for freshwater.

HULL ANODES (SPECIAL ORDERS)

BOLT HOLES CAN BE ADDED ON STRAPS AS REQUIRED

	PID	LB	KG		L	W	H	D	ID	UPC
Al	JDH40SBA	18.2	8.3	mm	305	152	67	140	14	6 28309 17369 2
Zn	JDH40SBZ	47.4	21.6	in	12	6	2.64	5.51	0.55	6 28309 23981 7

BOLT-ON

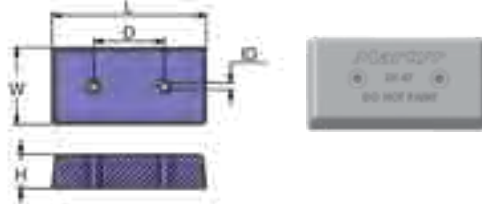

	PID	LB	KG		L	W	H	ID	UPC
Al	JDDM217A	20.90	9.50	mm	680	128	40	20	6 28309 17335 7
Zn	JDDM217Z	50.60	23.00	in	26.8	5	1.57	0.79	6 28309 17168 1

COMBO

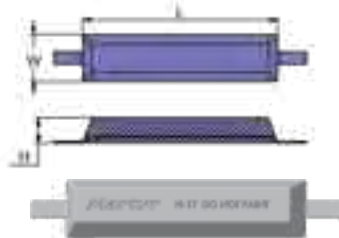

	PID	LB	KG		L	W	H	UPC
Al	JDH17GA	20.70	9.40	mm	510	123	66	6 28309 17347 0
Zn	JDH17GZ	51.50	23.40	in	20	4.84	2.6	6 28309 23974 9

WELD-ON



	PID	LB	KG		L	W	H	UPC
Al	JDH4GA	22.00	10.00	mm	600	120	50	6 28309 17203 9
Zn	JDH4GZ	52.40	23.80	in	23.6	4.7	1.97	6 28309 17374 6

WELD-ON

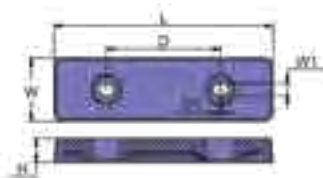

	PID	LB	KG		L	W	W1	H	D	D1	UPC
Al	JDH59GBA	21.1	9.6	mm	500	145	28	55	260	8	6 28309 17382 1
Zn	JDH59GBZ	60.7	27.6	in	19.7	5.7	1.1	2.17	10.24	0.31	6 28309 23985 5

BOLT-ON



	PID	LB	KG		L	W	H	UPC
Al	JDMA3305SA	25.10	11.40	mm	620	124	67	6 28309 17394 4
Zn	JDMA3305SZ	63.10	28.70	in	24.4	4.88	2.64	6 28309 23988 6

WELD-ON



Martyr
HULL ANODES (SPECIAL ORDERS)

HULL ANODES (SPECIAL ORDERS)

BOLT HOLES CAN BE ADDED ON STRAPS AS REQUIRED



	PID	LB	KG		L	W	H	UPC
Al	JDH34GA	26.40	12.00	mm	650	124	67	6 28309 17362 3
Zn	JDH34GZ	64.00	29.10	in	25.6	4.88	2.64	6 28309 23978 7

WELD-ON



	PID	LB	KG		L	W	H	UPC
Al	JDDM105GA	26.40	12.00	mm	800	123	42	6 28309 17331 9
Zn	JDDM105GZ	65.10	29.60	in	31.5	4.84	1.65	6 28309 23970 1

WELD-ON

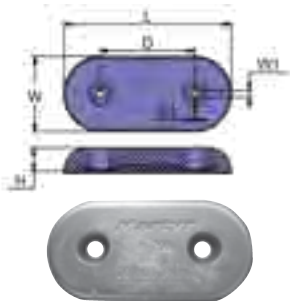

	PID	LB	KG		L	W	W1	H	D	D1	UPC
Al	JDH24GBA	25.30	11.50	mm	460	200	18	64	260	4	6 28309 17357 9
Zn	JDH24GBZ	64.90	29.50	in	18.1	7.87	0.71	2.52	10.25	0.16	6 28309 17194 0

BOLT-ON

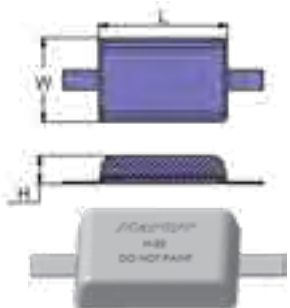

	PID	LB	KG		L	W	H	UPC
Al	JDH22GA	26.80	12.20	mm	320	210	70	6 28309 24018 9
Zn	JDH22GZ	67.10	30.50	in	12.6	8.27	2.76	6 28309 17191 9

BOLT-ON

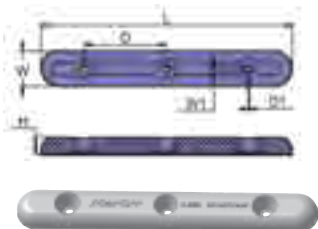

	PID	LB	KG		L	W	W1	H	D	D1	UPC
Al	JDH22GBA	26.80	12.20	mm	920	130	18	60	300	4	6 28309 17352 4
Zn	JDH22GBZ	83.60	38.00	in	36.2	5.1	0.71	2.36	11.81	0.16	6 28309 23975 6

BOLT-ON



	PID	LB	KG		L	W	H	UPC
Al	JDE2GA	45.50	20.70	mm	1000	100	80	6 28309 24015 8
Zn	JDE2GZ	111.00	50.40	in	39.4	3.94	3.15	6 28309 17175 9

WELD-ON

HULL ANODES (SPECIAL ORDERS)

HULL ANODES (SPECIAL ORDERS)

BOLT HOLES CAN BE ADDED ON STRAPS AS REQUIRED

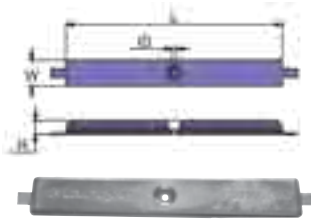

	PID	LB	KG		L	W	H	ID	UPC
Al	JD485GA	43.6	19.8	mm	1000	120	64	20	6 28309 17320 3
Zn	JD485GZ	110.0	50.0	in	39.4	4.7	2.5	0.79	6 28309 17145 2

COMBO

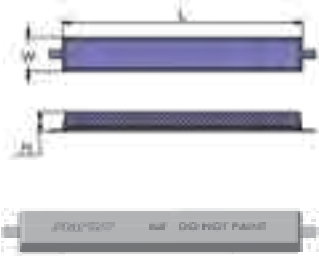

	PID	LB	KG		L	W	H		UPC
Al	JDH27GA	49.50	22.50	mm	920	130	75	6	28309 17361 6
Zn	JDH27GZ	124.80	56.70	in	36.2	5.12	2.95	6	28309 23977 0

WELD-ON

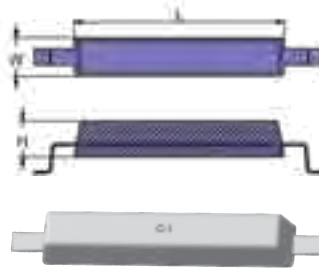

	PID	LB	KG		L	W	H		UPC
Al	JDC1GA	77.00	35.00	mm	760	139	130	6	28309 17328 9
Zn	JDC1GZ	189.00	86.00	in	30	5.5	5.12	6	28309 17158 2

WELD-ON

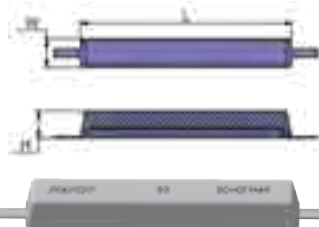

	PID	LB	KG		L	W	H		UPC
Al	JDE3GA	93.70	42.60	mm	1000	135	130	6	28309 17337 1
Zn	JDE3GZ	242.00	110.00	in	39.4	5.31	5.12	6	28309 17176 6

WELD-ON

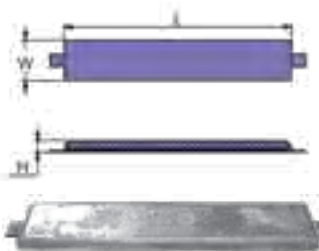

	PID	LB	KG		L	W	H		UPC
Al	JDH3GA	27.60	12.50	mm	800	140	40	6	28309 17368 5
Zn	JDH3GZ	67.00	30.40	in	31.50	5.5	1.57	6	28309 17200 8

WELD-ON

HULL ANODES (SPECIAL ORDERS)

BOLT HOLES CAN BE ADDED ON STRAPS AS REQUIRED

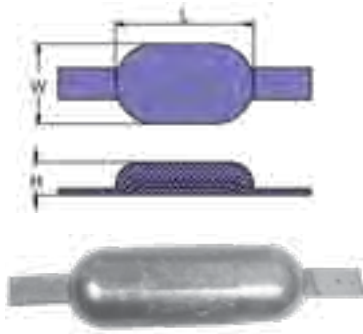

	PID	LB	KG		L	W	H	UPC
Al	SGSH506A	0.79	0.36	mm	115	60	17	6 28309 18246 5
Mg	SGSH506M	0.66	0.30					6 28309 18247 2
Zn	SGSH506Z	1.32	0.60	in	4.5	2.37	0.66	6 28309 18245 8
Al	SGSH507A	1.15	0.52	mm	110	63	26	6 28309 18249 6
Mg	SGSH507M	0.88	0.40					6 28309 18250 2
Zn	SGSH507Z	2.20	1.00	in	4.33	2.48	1	6 28309 18248 9
Al	SGSH508A	2.00	0.91	mm	200	70	26	6 28309 18252 6
Mg	SGSH508M	1.50	0.68					6 28309 18253 3
Zn	SGSH508Z	3.97	1.80	in	7.87	2.76	1.02	6 28309 18251 9
Al	SGSH509A	2.43	1.10	mm	215	70	29	6 28309 18255 7
Mg	SGSH509M	1.76	0.8					6 28309 18256 4
Zn	SGSH509Z	4.85	2.20	in	8.46	2.75	1.14	6 28309 18254 0
Al	SGSH510A	3.09	1.40	mm	200	90	35	6 28309 18258 8
Mg	SGSH510M	2.20	1.00					6 28309 18259 5
Zn	SGSH510Z	7.54	3.00	in	7.87	3.54	1.38	6 28309 18257 1

WELD-ON

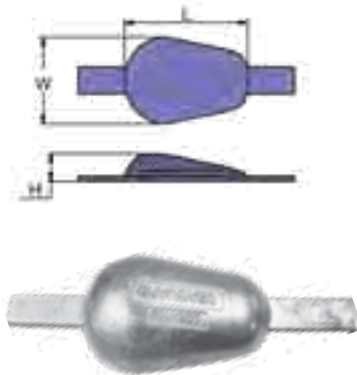

	PID	LB	KG		L	W	H	UPC
Al	SGSH100A	1.15	0.52	mm	118	80	26	6 28309 18220 5
Mg	SGSH100M	0.88	0.40					6 28309 18232 8
Zn	SGSH100Z	2.20	1.00	in	4.65	3.15	1	6 28309 18208 3
Al	SGSH101A	Please contact us for more info		mm	165	100	40	Please contact us for more info
Mg	SGSH101M							
Zn	SGSH101Z	6.61	3.00					
Al	SGSH159A	1.92	0.87	mm	140	90	40	6 28309 18221 2
Mg	SGSH159M	1.43	0.65					6 28309 18233 5
Zn	SGSH159Z	3.97	1.80	in	5.50	3.54	1.57	6 28309 18209 0

WELD-ON

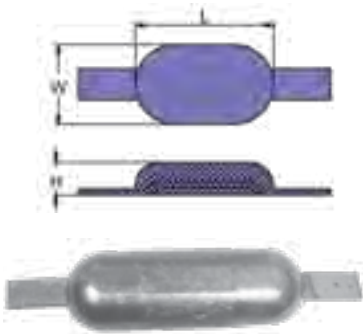

	PID	LB	KG		L	W	H	UPC
Al	SGSH16A	4.94	2.24	mm	300	80	40	6 28309 22624 4
Mg	SGSH16M	3.53	1.60					6 28309 22844 6
Zn	SGSH16Z	11.22	5.09	in	11.8	3.15	1.57	6 28309 22293 2
Al	SGSH25A	8.07	3.66	mm	320	147	40	6 28309 22625 1
Mg	SGSH25M	5.51	2.50					6 28309 22845 3
Zn	SGSH25Z	19.38	8.79	in	12.6	5.79	1.57	6 28309 22294 9

WELD-ON

HULL ANODES (SPECIAL ORDERS)

Choose
Aluminum

Al premium
SALT AND BRACKISH WATER

Anodes for
salt and brackish
water and
Magnesium

Mg fresh
FRESH WATER ONLY
for freshwater.

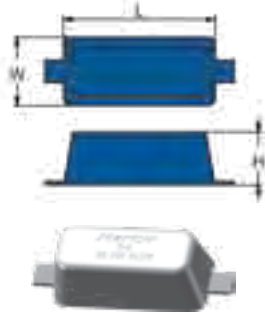

BALLAST TANK ANODES (SPECIAL ORDERS)

BOLT HOLES CAN BE ADDED ON STRAPS AS REQUIRED

	PID	LB	KG		L	W	H	UPC	
Al	JDZT8GA	6.60	3.00	mm	200	90	70	6 28309 24041 7	
Zn	JDZT8GZ	16.50	7.50	in	7.88	3.5	2.8	6 28309 24007 3	

WELD-ON



	PID	LB	KG		L	W	H	H1	D	ID	UPC	
Al	JDT9GA	9.0	4.1	mm	400	70	60	100	20	15	6 28309 24038 7	
Zn	JDT9GZ	22.0	10.0	in	15.7	2.75	2.36	3.94	0.79	0.59	6 28309 17302 9	

COMBO

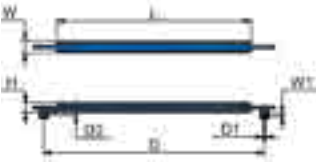

	PID	LB	KG		L	W	H	H1	D	D1	UPC	
Al	JDI13GA	11.00	5.0	mm	820	50	12	43	93	9	6 28309 17392 0	
Zn	JDI13GZ	25.33	11.5	in	32	2	0.5	1.7	36.7	0.35	6 28309 23986 2	

COMBO



	PID	LB	KG		L	W	H	UPC	
Al	JDT13GA	12.30	5.60	mm	500	60	60	6 28309 17414 9	
Zn	JDT13GZ	28.60	13.00	in	19.7	2.36	2.36	6 28309 24000 4	

WELD-ON



	PID	LB	KG		L	W	H	UPC	
Al	JDGBZT01A	14.50	6.60	mm	516	69	63	6 28309 17340 1	
Zn	JDGBZT01Z	34.40	15.60	in	20.3	2.72	2.48	6 28309 17181 0	

WELD-ON

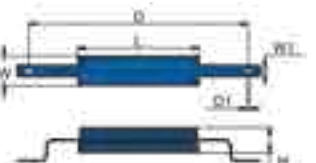

	PID	LB	KG		L	W	W1	H	D	D1	UPC	
Al	JDT12GA	19.8	9.0	mm	400	100	16	85	720	10	6 28309 17413 2	
Zn	JDT12GZ	48.4	22.0	in	15.7	3.94	0.63	3.35	28.3	0.4	6 28309 23999 2	

COMBO



Martyr
BALLAST TANK ANODES (SPECIAL ORDERS)

BALLAST TANK ANODES (SPECIAL ORDERS)

BOLT HOLES CAN BE ADDED ON STRAPS AS REQUIRED



	PID	LB	KG		L	W	H	UPC
Al	JD237A	22	10	mm	800	74	64	6 28309 24008 0
Zn	JD237Z	55	25	in	32	3	2.5	6 28309 23966 4

WELD-ON



	PID	LB	KG		L	W	H	UPC
Al	JDT3GA	44	20	mm	500	130	120	6 28309 17425 5
Zn	JDT3GZ	108.5	49.3	in	19.7	5.2	4.7	6 28309 24004 2

COMBO

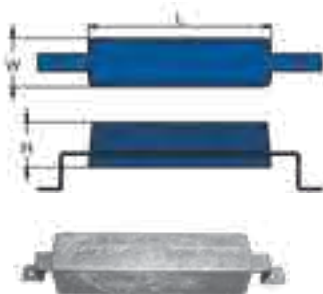

	PID	LB	KG		L	W	H	UPC
Al	JDT1GA	50.6	23	mm	500	135	130	6 28309 17422 4
Zn	JDT1GZ	131	59.5	in	19.7	5.3	5.1	6 28309 24002 8

COMBO



	PID	LB	KG		L	W	H	UPC
Al	JDI17GA	176	80	mm	700	83	83	6 28309 17393 7
Zn	JDI17GZ	449	204	in	27.6	3.27	3.27	6 28309 23987 9

COMBO

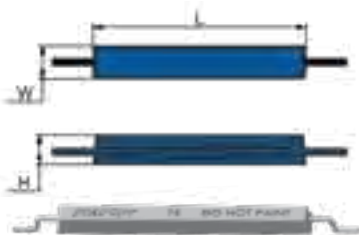

	PID	LB	KG		L	W	H	UPC
Al	JDT14GA	16.3	7.4	mm	500	70	70	6 28309 17416 3
Zn	JDT14GZ	38.8	17.6	in	19.7	2.76	2.76	6 28309 17294 7

WELD-ON



	PID	LB	KG		L	W	H	UPC
Al	JDT11GA	8.1	3.7	mm	200	90	70	6 28309 17412 5
Zn	JDT11GZ	18.7	8.5	in	7.9	3.54	2.76	6 28309 17293 0

WELD-ON

BALLAST TANK ANODES (SPECIAL ORDERS)

BALLAST TANK ANODES (SPECIAL ORDERS)

BOLT HOLES CAN BE ADDED ON STRAPS AS REQUIRED

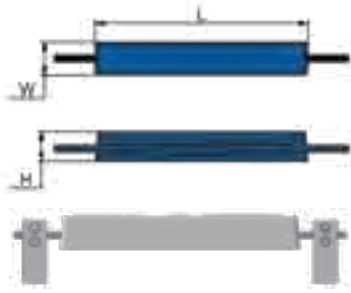

	PID	LB	KG		L	W	H	UPC
Al	JDT14GAF	16.3	7.4	mm	500	70	70	6 28309 17417 0
Zn	JDT14GZF	39.2	17.8	in	19.7	2.76	2.76	6 28309 17295 4

BOLT-ON



	PID	LB	KG		L	W	H	UPC
Al	JDT15GA	36.3	16.5	mm	1000	80	80	6 28309 24037 0
Zn	JDT15GZ	90.2	41	in	39.4	3.15	3.15	6 28309 17296 1

WELD-ON



	PID	LB	KG		L	W	H	UPC
Al	JDT16GA	11.7	5.3	mm	730	80	80	6 28309 17418 7
Zn	JDT16GZ	26.4	12	in	28.7	3.15	3.15	6 28309 24001 1

WELD-ON

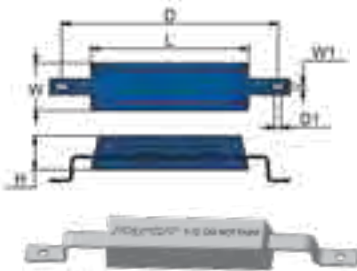

	PID	LB	KG		L	W	W1	H	D	D1	UPC
Al	JDT19GA	22.4	10.2	mm	400	120	13	85	548	17	6 28309 17420 0
Zn	JDT19GZ	59	26.8	in	15.7	4.72	0.5	3.35	21.6	0.67	6 28309 17421 7

COMBO

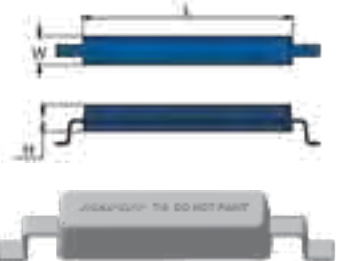

	PID	LB	KG		L	W	H	UPC
Al	JDT22GA	16.9	7.7	mm	550	75	70	6 28309 17424 8
Zn	JDT22GZ	40.9	18.6	in	21.7	2.95	2.76	6 28309 24003 5

WELD-ON

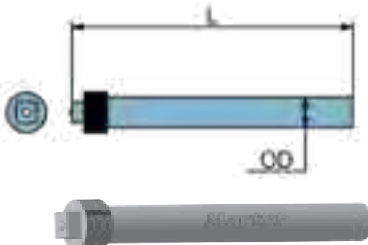

HEAT EXCHANGER ANODES

	PID	LB	KG		L	OD	UPC
Zn	JDROD25DZ	1.78	0.81	mm	228	25	6 28309 17245 9
				in	9	1	

HEAT EXCHANGER ANODES

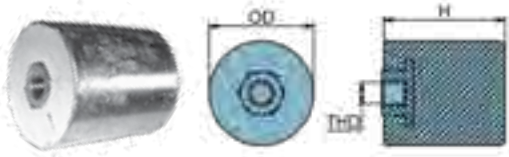

	PID	LB	KG		L	OD	THD	UPC
Zn	JDROD69DZ	4.50	2.04	mm	80	69	M16	6 28309 17277 0
				in	3.15	2.7		

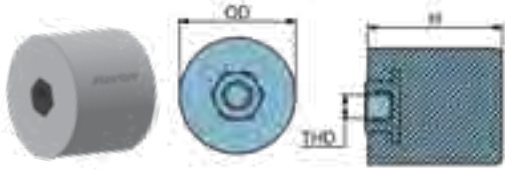

	PID	LB	KG		L	OD	THD	UPC
Zn	JDROD100DZ	9.57	4.35	mm	80	100	M16	6 28309 17227 5
				in	3.15	4		

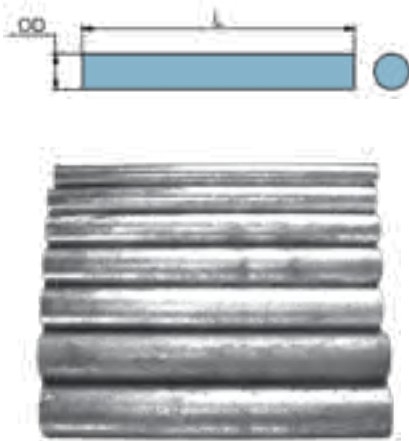

ROD STOCK ANODES

	PID	LB	KG		L	OD	UPC
Al	JDROD25A	1.00	0.45	mm	300	25	6 28309 17434 7
Zn	JDROD25Z	2.42	1.10	in	11.81	1	6 28309 17247 3
Al	JDROD30A	1.34	0.61	mm	300	30	6 28309 17397 5
Zn	JDROD30Z	3.30	1.50	in	11.81	11.81	6 28309 17254 1
Al	JDROD40A	2.40	1.09	mm	300	40	6 28309 17399 9
Zn	JDROD40Z	5.95	2.70	in	11.81	1.5	6 28309 17262 6
Al	JDROD45A	3.04	1.38	mm	300	45	6 28309 17400 2
Zn	JDROD45Z	7.49	3.40	in	11.81	1.75	6 28309 17264 0
Al	JDROD50A	3.74	1.70	mm	300	50	6 28309 17401 9
Zn	JDROD50Z	9.24	4.20	in	11.81	2	6 28309 17269 5
Al	JDROD55A	4.54	2.06	mm	300	55	6 28309 17402 6
Zn	JDROD55Z	11.23	5.10	in	11.81	2.25	6 28309 17272 5
Al	JDROD60A	5.44	2.47	mm	300	60	6 28309 17403 3
Zn	JDROD60Z	13.44	6.10	in	11.81	2.37	6 28309 17275 6
Al	JDROD65A	6.32	2.87	mm	300	65	6 28309 17404 0
Zn	JDROD65Z	15.64	7.10	in	11.81	2.5	6 28309 17276 3
Al	JDROD70A	7.40	3.36	mm	300	70	6 28309 17405 7
Zn	JDROD70Z	18.28	8.30	in	11.81	2.75	6 28309 17279 4
Al	JDROD75A	8.48	3.85	mm	300	75	6 28309 17406 4
Zn	JDROD75Z	20.90	9.50	in	11.81	3	6 28309 17280 0
Al	JDROD80A	9.71	4.41	mm	300	80	6 28309 17407 1
Zn	JDROD80Z	24.00	10.90	in	11.81	3.12	6 28309 17281 7
Al	JDROD85A	10.97	4.98	mm	300	85	6 28309 17408 8
Zn	JDROD85Z	27.10	12.30	in	11.81	3.37	6 28309 17284 8
Al	JDROD90A	12.22	5.55	mm	300	90	6 28309 17409 5
Zn	JDROD90Z	30.18	13.70	in	11.81	3.5	6 28309 17287 9

ROD STOCK ANODES (SPECIAL ORDERS)

Choose
Aluminum

Al premium
SALT AND BRACKISH WATER

Anodes for
salt and brackish
water and
Magnesium

Mg fresh
FRESH WATER ONLY
for freshwater.

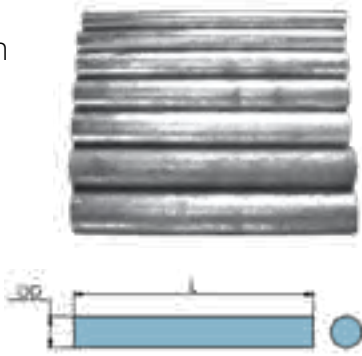

ROD STOCK ANODES

	PID	LB	KG		L	OD	UPC
Al	JDROD95A	13.63	6.19	mm	300	95	6 28309 17410 1
Zn	JDROD95Z	33.70	15.30	in	11.81	3.75	6 28309 17288 6
Al	JDROD100A	15.15	6.88	mm	300	100	6 28309 17631 0
Zn	JDROD100Z	37.44	17.00	in	11.81	4	6 28309 17228 2
Al	JDROD105A	16.67	7.57	mm	300	105	6 28309 17395 1
Zn	JDROD105Z	41.20	18.70	in	11.81	4.12	6 28309 17229 9
Al	JDROD110A	18.28	8.30	mm	300	110	6 28309 17586 3
Zn	JDROD110Z	45.15	20.5	in	11.81	4.37	6 28309 17230 5
Al	JDROD115A	20.00	9.07	mm	300	115	6 28309 17396 8
Zn	JDROD115Z	49.34	22.40	in	11.81	4.5	6 28309 17231 2

Martyr

ROD STOCK ANODES (SPECIAL ORDERS)

PID INDEX (ALPHANUMERIC)

10421419	141	CM338602182Z/A/M	106	CM431708Z/A/M	79
10421420	141	CM338635Z/A/M	77	CM43396Z/A/M	93
10421421	141	CM34127Z/A/M	92	CM434029Z	79
10421422	141	CM34762Z/A/M	92	CM43994Z/A/M	93
ARNLARGE/A/M	143	CM348602170Z/A/M	107	CM46399Z/A/M	93
ARNSMALL/A/M	143	CM355964Z/A/M	77	CM47820A1Z/A/M	93
CM06411ZV5Z/A/M	87	CM357507Z/A/M	77	CM5007089Z/A/M	80
CM06411ZW1Z/A/M	87	CM358407Z/A/M	117	CM5008813Z/A/M	80
CM09411Z/A/M	92	CM3584442KITZ/A/M	126	CM5009138Z/A/M	80
CM1000Z/A/M/AA	160	CM3588745Z/A/M	117	CM500Z/A/M/AA	158
CM1113094600Z/A/M	113	CM3589875Z/A/M	118	CM5031538Z/A/M	80
CM12065013420PZ	152	CM3593881Z/A/M	118	CM5031705Z	80
CM12065013420Z	152	CM35GZ/A	159	CM5032929Z/A/M	80
CM123009Z/A/M	77	CM367Z/A/M	77	CM51525Z/A/M	141
CM1301341PZ	149	CM369602181Z	107	CM5338602182A0Z/A/M	106
CM1331818PZ	150	CM36BSSZ/A	165	CM5512587D00Z/A/M	113
CM1331818Z	150	CM37GZ/A	161	CM5512587E01Z/A/M	115
CM14072100Z/A/M	49	CM3841427Z/A/M	118	CM5512594502Z/A/M	114
CM14073100Z/A/M	49	CM3852970Z/A/M	118	CM5512595301Z/A/M	114
CM14074100Z/A/M	49	CM3854130Z/A/M	118	CM5512595500Z/A/M	81, 114
CM14074511Z/A/M	49	CM3855411Z/A/M	119	CM551259630Z/A/M	113
CM15500000Z/A/M	49	CM3858399KITZ/A/M	125	CM5530095500Z/A/M	115
CM15527500Z/A/M	49	CM3861634Z/A/M	119	CM5532095310Z/A/M	113
CM15530000Z/A/M	49	CM3861636Z/A/M	119	CM5532098400Z/A/M	114
CM15539500Z/A/M	49	CM3863206Z/A/M	119	CM5532098400Z/A/M	81
CM15540000Z/A/M	49	CM3883728Z/A/M	119	CM5532098600Z/A/M	114
CM15670000Z/A/M	49	CM389999Z/A/M	78	CM5532098600Z/A/M	81
CM1661GZ/A	165	CM392123Z/A/M	78	CM5532187J00Z/A/M	115
CM1874SZ/A/M	179	CM392462Z/A/M	78	CM5532187J00Z/A/M	81
CM2000Z/A/M/AA	162	CM393023Z/A/M	78	CM5532190J01Z/A/M	115
CM200Z/A/M/AA	157	CM39315GZ/A	164	CM5532190J01Z/A/M	81
CM21718129Z/A/M	117	CM395780Z/A/M	78	CM5532193900Z	81
CM22651246Z	117	CM397768Z/A/M	79	CM5532193900Z/A/M	115
CM2431GZ/A	160	CM398331Z/A/M	79	CM5532194900Z/A/M	113
CM2500050Z/A/M	111	CM398873Z/A/M	79	CM55989KITA/M	102
CM2500065Z	112	CM3B76021700Z/A/M	107	CM55989Z/A/M	93
CM2504015Z/A/M	112	CM3B7602181Z/A/M	107	CM589150KITZ/A/M	61
CM260BSZ/A	171	CM3C7602181A0Z/A/M	106	CM589150Z/A/M	61
CM260SZ/A	171	CM3C86021700Z/A/M	107	CM589350KITZ/A/M	61
CM2624SZ/A/M	179	CM3H660218000Z/A/M	106	CM589350Z/A/M	61
CM2631GZ/A	162	CM3M2602181Z/A/M	107	CM589550KITZ/A/M	61
CM27210200370Z	152	CM3V1602170Z/A/M	106	CM589550Z/A/M	61
CM27210200550Z	152	CM40005206Z/A/M	120	CM590140552Z/A/M	86
CM273125GZ/A	164	CM40005875Z/A/M	122	CM590163243Z/A/M	86
CM280DPKITZ/A/M	124	CM41100098Z/A/M	123	CM59066209Z/A/M	86
CM280KITZ/A/M	124	CM41100276Z/A/M	124	CM61A1132500Z/A/M	133
CM2874SZ/A/M	179	CM41106ZW000Z/A/M	126	CM61A4537100Z/A/M	133
CM290DPEUKITZ/A/M	126	CM41106ZW9000Z/A/M	89	CM61N4525101Z/A/M	133
CM290DPKITZ/A/M	125	CM41107ZV500Z/A/M	88	CM62Y1132500Z/A/M	109, 133
CM290EUKITZ/A/M	126	CM41107ZW1003Z/A/M	88	CM63D4525101Z/A/M	108, 134
CM290KITZ/A/M	124	CM41107ZW1B01Z/A/M	88	CM63P1132501Z/A/M	134
CM31640KITA/M	102	CM41109ZW1003Z/A/M	87	CM63P1132511Z/A/M	134
CM31640Z/A/M	92	CM41109ZW1B00Z/A/M	88	CM656934Z/A/M	142, 157
CM327606Z/A/M	77	CM4181198500Z/A/M	115	CM6634525100Z/A/M	108
CM334451Z/A/M	77	CM42121Z/A/M	127	CM6644537101Z/A/M	87, 135
CM335Z/A/M	158	CM42121Z/A/M	92	CM66M1132500Z/A/M	109, 134

CM66M4537100Z/A/M	134	CM6U34525101Z/A/M	132	CM8517479Z	148, 151
CM6761132500Z/A/M	110	CM6U44525100Z/A/M	132	CM8517480BSZ	148
CM6764525100Z/A/M	110	CM6U44537300Z/A/M	133	CM852018Z/A/M	121
CM6794525100Z/A/M	136	CM762144KITA/M	105	CM8520219Z/A/M	124
CM67C4525100Z/A/M	110, 112, 135	CM762144Z/A/M	94	CM852835Z/A/M	121
CM67C4537100Z/A/M	135	CM762145KITA/M	105	CM855105Z/A/M	123
CM67F1132500Z/A/M	135	CM762145Z/A/M	94	CM856581CZ/A/M	97
CM67F1132501Z/A/M	135	CM76214Q5Z/A/M	94	CM85824A3Z/A/M	97
CM67F4537100Z/A/M	136	CM76214Z/A/M	94	CM865182KITA/M	104
CM6821132500Z/A/M	109	CM8018Z/A/M	109	CM872139Z/A/M	121
CM6881132500Z/A/M	110, 137	CM804079002Z/A/M	94	CM872793Z/A/M	121
CM6884525101Z/A/M	137	CM806105KITA/M	105	CM873395Z/A/M	121
CM6884537102Z/A/M	137	CM806105Z/A/M	94	CM875812Z/A/M	122
CM6891132500Z/A/M	110, 137	CM806188KITA/M	105	CM875821Z/A/M	122
CM68T1132500Z/A/M	136	CM806188Z/A/M	95	CM876638Z/A/M	123
CM68T4525100Z/A/M	136	CM806189KITA/M	105	CM880653Z/A/M	98
CM68V1132501Z/A/M	137	CM806189Z/A/M	95	CM892227Z/A/M	98
CM69L4537100Z/A/M	138	CM806190KITA/M	105	CM8925832Z	148
CM6AW4525100Z/A/M	127	CM806190Z/A/M	95	CM89949Z/A/M	98
CM6AW4537300Z/A/M	127	CM8101772PZ	146	CM8M0001734Z/A/M	98
CM6AW4561900Z/A/M	127	CM8101772Z	146	CM8M0012083Z/A/M	99
CM6BL1132500Z/A/M	127	CM8105277PZ	146	CM8M0039340KITZ/A/M	101
CM6E04525111Z/A/M	89, 128	CM8105277Z	146	CM8M0039340Z/A/M	99
CM6E51132500Z/A/M	109, 128	CM8109743PZ	146	CM8M0057772Z/A/M	99
CM6E54525100Z/A/M	128	CM8109743Z	146	CM8M0107548KITZ/A/M	101
CM6E54537101Z/A/M	128	CM810SZA	167	CM8M0116590KITZ/A/M	101
CM6E54537110Z/A/M	130	CM812125SZ/A/GA/GZ	168	CM9005660Z/A/M	111
CM6E84525100Z/A/M	128	CM812SZ/A/GA/GZ	170	CM9135033Z/A/M	91
CM6E84525102Z/A/M	131	CM818298KITA/M	104	CM9135034Z/A/M	91
CM6G14525102Z/A/M	131	CM818298Z/A/M	95	CM94286T1Z/A/M	99
CM6G14525103Z/A/M	131	CM821629CZ/A/M	95	CM970494635PZ	149
CM6G54525101Z/A/M	129	CM821629KITA/M	104	CM970494635Z	149
CM6G81132500Z/A/M	108, 129	CM821630C2Z/A/M	95	CM980756Z/A/M	82
CM6G84525101Z/A/M	129	CM821630KITA/M	104	CM982277Z/A/M	82
CM6H14525101Z/A/M	129	CM821631KITA/M	104	CM982438Z	82
CM6H14525102Z/A/M	129	CM821631Z/A/M	96	CM983494Z/A/M	82
CM6H31132501Z/A/M	108	CM822157C2Z/A/M	96	CM983952Z/A/M	83
CM6J81132500Z/A/M	86	CM822777Z/A/M	96	CM984325Z	100
CM6J94537101Z/A/M	130	CM823661Z/A/M	120, 151	CM984513Z/A/M	83
CM6K14537100Z/A/M	130	CM8239121Z/A/M	96	CM984547Z/A/M	83
CM6K14537102Z/A/M	130	CM823912Z/A/M	96	CM986158Z/A/M	83
CM6L2016PZ	147	CM825271Z/A/M	97, 138	CM987067Z/A/M	83
CM6L2016Z	147	CM826134KITA/M	104	CMAC073Z/A/M	68
CM6L2280GPZ	147	CM826134Z/A/M	97	CMAF720Z	146
CM6L2280GZ	147	CM826887MZ/A/M	97	CMAF920PZ	146
CM6L2283PZ	147	CM82795MZ/A/M	112, 138	CMAF920Z	146
CM6L2283Z	147	CM828140Z/A/M	123	CMALPHAGEN1KITZ/A/M	103
CM6L2284Z	147	CM832598Z/A/M	120	CMALPHAKITZ/A/M	102
CM6L2285Z	147	CM832934Z/A/M	122	CMAN225/A/M	46
CM6L2288Z	147	CM833913Z/A/M	123	CMAN225EUZ/A/M	53
CM6L2289PZ	147	CM833915Z/A/M	123	CMAN230/A/M	46
CM6L2289Z	147	CM838929Z/A/M	120, 151	CMAN230EUZ/A/M	53
CM6L3104PZ	147	CM847635001Z/A/M	97	CMAN235/A/M	46
CM6L3104Z	147	CM8515842BSZ	148	CMAN235EUZ/A/M	53
CM6L54525102Z/A/M	130	CM8515842Z	148	CMAN240/A/M	46
CM6T44583600Z/A/M	131	CM8515850Z	147, 148	CMAN240EUZ/A/M	54
CM6T54537100Z/A/M	131	CM8515851Z	148	CMAN245/A/M	46
CM6T54537300Z/A/M	132	CM8517479BSZ	148	CMAN245EUZ/A/M	46, 54
CM6U04525100Z/A/M	132	CM8517479PZ	148	CMAN250/A/M	46, 54

CMAN255/A/M	46, 54	CMC75/A/M	38	CMEBP71638	147
CMAN260/A/M	46, 54	CMC80/A/M	39	CMEBP716B12	148
CMANCHN700/A/M	46	CMC85Z/A/M	39	CMEBP816	149
CMAR580Z/A/M	143	CMC90/A/M	39	CMEBP824	146
CMAR670Z	143	CMCA1230Z	147	CMEBP838	149
CMAR671Z	143	CMCDZ8126SZ/A/M	168	CMEBP8514	148
CMAR672Z	143	CMCDZ886SZ/A/M	166	CMEBPD838	149
CMARCHN/A	162	CMCH006Z	68	CMECU16PZ	148
CMB00E0450	146	CMCOBRAKITZ/A/M	84	CMECU16Z	148
CMB00E0450/A/M	86	CMCTHBZ/A/M	174	CMEP0	145
CMB00E5829Z/A/M	86	CMCU1020PZ	148	CMEP00	145
CMBNT1AKITZ/A/M	141	CMCU1020Z	148	CMEP1	145
CMBNT1AZ/A/M	141	CMCU1645Z	148	CMEP2	145
CMBRAVO1KITZ/A/M	102	CMCU1650PZ	148	CMEP2BSP	145
CMBRAVO23KITZ/A/M	102	CMCU1650Z	148	CMEP3	145
CMBRAVO3KITZ/A/M	102	CMCU1865Z	148	CMEP3BSP	145
CMBW043Z	85	CMDEICERZ/A/M	141	CMEP5834	148
CMBW044Z	85	CMDIVERBONDA	64	CMEPHS1420	150
CMBW172Z	85	CMDIVERHZ/A/M	65	CMERE14PZ	150
CMBW173Z	85	CMDIVERMINI/A/M	64, 160	CMERE14Z	150
CMBW175Z	85	CMDIVERMINIHZ/A/M	65	CMEREBP18	150
CMBW499Z	85	CMDIVERZ/A/M	65, 165	CMETECG2KITZ/A/M	84
CMC01/AL/M	37	CMDPHKITZ/A/M	125	CMEZ0	145
CMC02/AL/M	37	CME0	144	CMEZ00	145
CMC03/AL/M	37	CME00	144	CMEZ0AZ	145
CMC04/AL/M	37	CME0AZ	144	CMEZ1	145
CMC05/AL/M	37	CME1	144	CMEZ1D	145
CMC06/AL/M	37	CME1D	144	CMEZ1E	145
CMC07/AL/M	37	CME1E	144	CMEZ1F	145
CMC08Z/AL/M	37	CME1F	144	CMEZ1G	145
CMC09/AL/M	37	CME1G	144	CMEZ1H	145
CMC09A/AL/M	37	CME1H	144	CMEZ2	145, 148
CMC100/A/M	39	CME2	144	CMEZ2BZ	145
CMC12/AL/M	37	CME2BSP	144	CMEZ2S	145, 148, 151
CMC120/A/M	39	CME2BZ	144	CMEZ3	145
CMC12A/AL/M	37	CME2S	144	CMEZ3S	145
CMC13/AL/M	37	CME3	144	CMEZ4	145
CMC14/AL/M	37	CME3BSP	144	CMEZ4SL	148
CMC15/AL/M	38	CME3S	144	CMEZ5	145
CMC20/AL/M	38	CME4	144	CMF110CZ/A/M	41
CMC22EURO/A/M	39	CME5	144	CMF110Z/A/M	40
CMC25/AL/M	38	CMEAF720PZ	146	CMF125CZ/A/M	41
CMC25EURO/A/M	39	CMEBD20PZ	146	CMF125PB4TPZ/A/M	166
CMC30/AL/M	38	CMEBD20Z	146	CMF125Z/A/M	40
CMC30EURO/A/M	39	CMEBP1018	146	CMF130SPZ/A/M	41
CMC35/AL/M	38	CMEBP1212	148	CMF140CZ/A	41
CMC35EURO/A/M	39	CMEBP1414	147	CMF140Z/A/M	41
CMC40/AL/M	38	CMEBP1428	146	CMF190Z/A/M	41
CMC40EURO/A/M	39	CMEBP2230	149	CMF50CZ/A/M	41
CMC45/A/M	38	CMEBP3812	147	CMF50Z/A/M	40
CMC45EURO/A/M	39	CMEBP4512	146	CMF70CZ/A/M	41
CMC50/A/M	38	CMEBP510	146	CMF70SPZ/A/M	41
CMC50EURO/A/M	39	CMEBP5834	147	CMF70Z/A/M	40
CMC55Z/A/M	38	CMEBP612	150	CMF90BZ/A/M	75
CMC60/A/M	38	CMEBP638	148	CMF90CZ/A/M	41
CMC65Z/A/M	38	CMEBP712	146	CMF90SPZ/A/M	41
CMC6C50BZ/A	173	CMEBP71612	148	CMF90Z/A/M	40
CMC6C75BZ/A	173	CMEBP71612L	148	CMFE1Z/A/M	47
CMC70/A/M	38	CMEBP71618	152	CMFE2Z/A/M	47

CMFE3Z/A/M	47	CMLAEC3300/A/M	45	CMOLY/A	175	CMPN04Z/A	175
CMFE4Z/A/M	47	CMLAEC3300EUZ/A/M	52	CMOLY1HZ/A	175	CMPN05Z/A	175
CMFE5Z/A/M	48	CMLAEC3500/A/M	45	CMOMC5075KITZ/A/M	84	CMPN06Z/A	176
CMFE80Z/A/M	47	CMLAEC3500EUZ/A/M	52	CMOMCV4V6KITZ/A/M	84	CMPN07Z/A	176
CMFL074Z/A/M	71	CMLAEC4000/A/M	45	CMON1030Z	149	CMPN08Z/A	176
CMFL075FZ/A/M	73	CMLAEC4000EUZ/A/M	52	CMON1131PZ	149	CMPN09Z/A	176
CMFL075Z/A/M	71	CMLAEC4500/A/M	45	CMON1131Z	149	CMPN10Z/A	176
CMFL076FZ/A/M	73	CMLAEC4500EUZ/A/M	45, 53	CMON1326Z	149	CMPN11Z/A	176
CMFL076Z/A/M	71	CMLAEC5000/A/M	45, 53	CMOU686Z/A/M	58	CMPN12Z/A	176
CMFL465Z/A/M	143	CMLAEC5500/A/M	45, 53	CMP0515115Z/A	176	CMPN13BZ/A	176
CMFL465Z/A/M	73	CMLAEC6000/A/M	45, 53	CMP051512Z/A	176	CMPN13Z/A	176
CMFO1018PZ	148	CMLCAZ/A/M	142	CMP05204Z/A	176	CMPNA/CMPNWA	176
CMFO1018Z	148	CMLCBZ/A/M	142	CMP05212Z/A	176	CMPNAZC13/AC13/MC13	43
CMFO1332Z	148	CMLCCDEZ/A/M	142	CMP05224Z/A	176	CMPNBZC11/AC11/MC11	43
CMGROUPER/A/M	63	CMLCF1Z/A/M	142	CMP05303Z/A	176	CMPNCZC10/AC10/MC10	43
CMH06Z/A	166	CMM120BZ/A	170	CMP05306WZ	178	CMPNCZF16	100
CMH18BZ	160	CMM24Z/A/M	66, 157	CMP05306Z/A	177	CMPNCZF16/AF16/MF16	43
CMH19BZ/A/M	169	CMM25/A/M	66, 161	CMP05312Z	177	CMPNDZ/A/M/F14UNS	100
CMH1B6GZ/A	174	CMM30/A/M	66, 159	CMP05406Z/A	177	CMPNDZC09/AC09/MC09	43
CMH20BZ/A/M	167	CMM3060KITZ/A/M	101, 103	CMP05606WZ	178	CMPNDZF14/AF14/MF14	43
CMH2B11Z/A	174	CMM40/A/M	66, 159	CMP05606Z/A	177	CMPNEZ/A/M/F14	100
CMH2B2Z/A	174	CMM75115KITZ/A/M	103	CMP05612WZ/A	178	CMPNEZC08/AC08/MC08	43
CMH2B3Z/A	174	CMMA2204SZ/A/GA/GZ	170	CMP05612Z/A	177	CMPNEZF14/AF14/MF14	43
CMH2B4Z/A	174	CMMA2244LZ/A	171	CMP075106Z/A	177	CMPNFF2KITZ/A/M	48
CMH2B5Z/A	174	CMMA2244SZ/A	171	CMP075303Z/A	177	CMPNFF2Z/A/M	48
CMH2B6Z/A	174	CMMA2602SZ/A	173	CMP075306WZ/A	178	CMPNFXZ/A/M	48
CMHBF35225KITZ/A/M	89	CMMA31003Z/A	173	CMP075306Z/A	177	CMPNFZC07/AC07/MC07	43
CMHBF4050KITZ/A/M	89	CMMA3305SZ/A	172	CMP075406WZ/A	178	CMPNGZC07/AC07/MC07	43
CMHBF75115KITZ/A/M	89	CMMA3365CSZ/A	172	CMP075406Z/A	177	CMPNH5Z/A/M	44
CMHS1760PZ	150	CMMA3602SZ/A	173	CMP075606Z/A	177	CMPNH6Z/A/M	44
CMHS1760Z	150	CMMA41004Z/A	173	CMP075612Z/A	177	CMPNH9Z/A/M	44
CMHT1/A	163	CMMA4545CSZ/A	172	CMP11504Z/A	177	CMPNHZC06/AC06/MC06	43
CMHT321Z/A	175	CMMG10GM	170	CMP11505Z/A	177	CMPNRAD100C/A/M	55
CMHT330Z/A	175	CMMG24GM	171	CMP1206Z/A	177	CMPNRAD100Z/A/M	56
CMIF2034PZ	149	CMMG5GM	167	CMP1303Z/A	177	CMPNRAD225C/A/M	55
CMIF2034Z	149	CMMGJRGM	165	CMP1304Z/A	177	CMPNRAD225C/A/M	55, 56
CMIQ648Z	58	CMMP100MZ/A/M	51	CMP1306Z/A	177	CMPNRAD30C/A/M	55, 56
CMJP60Z/A/M	50	CMMP125MZ/A/M	51	CMP1406Z/A	177	CMPNRAD35/A/M	56
CMJPROP60Z/A/M	50	CMMP586Z/A/M	61	CMP1606Z/A	177	CMPNRAD35C/A/M	55
CMJPROP80Z/A/M	50	CMMP63M2BZ/A/M	52	CMP1612Z/A	177	CMPNRAD40/A/M	56
CMJPROP90Z/A/M	50	CMMP63MZ/A/M	51	CMP166Z/A	178	CMPNRAD40C/A/M	55
CMKA614Z/A/M	90	CMMP63RZ/A/M	50	CMP5B2BZ/A/GSA/GSZ		CMPNRAD45/A/M	56
CMKA615Z/A/M	90	CMMP676Z/A/M	61	... /AA/AZ	169	CMPNRAD45C/A/M	55
CMKA616Z/A/M	90	CMMP70MZ/A/M	51	CMP631Z/A	178	CMPNRAD50/A/M	56
CMKA617Z/A/M	90	CMMP70RZ/A/M	50	CMP7B2BSZ/A	170	CMPNRAD50C/A/M	55
CMKA618Z/A/M	90	CMMP70SDZ/A/M	51	CMPL078Z/A/M	73	CMPNRAD55/A/M	56
CMKA619Z/A/M	90	CMMP83MZ/A/M	51	CMPL357Z/A/M	73	CMPNRAD55C/A/M	55
CMKA620Z/A/M	90	CMMP83RZ/A/M	50	CMPL378Z/A/M	73	CMPNRAD60/A/M	56
CMKA621Z/A/M	90	CMMP83SDZ/A/M	51	CMPL400Z/A/M	73	CMPNRAD60C/A/M	55
CMKA622Z/A/M	91	CMMTF1Z/A/M	52	CMPL401Z/A/M	73	CMPNSOLE1/A/M	59
CMKA623Z/A/M	91	CMMTF2Z/A/M	52	CMPL419Z	73	CMPNSOLE2/A/M	59
CMKA624Z/A/M	91	CMMTF3Z/A/M	52	CMPL505Z/A/M	70	CMPNSOLE3/A/M	59
CMKA730Z/A/M	90	CMMZ404/A	161	CMPL574Z/A/M	73	CMPNSOLE4/A/M	59
CMKK1Z/A/M	179	CMMZ404/A/M	67	CMPMA/CMPMWA	176	CMPNWZ/A/M	67
CMKK2Z/A/M	179	CMMZC406/A/M	67, 164	CMPMWZ/A/M	67	CMPNZ/CMPNWZ	176
CMKK3Z/A/M	179	CMN1HZ/A/M	67, 160	CMPMZ/CMPMWZ	176	CMPNZA/AA/MA	44
CMLAEC10000/A/M	45, 53	CMN1Z/A/M	67, 160	CMPN01Z/A	175	CMPNZB/AB/MB	44
CMLAEC3250/A/M	45	CMNN2525PZ	149	CMPN02Z/A	175	CMPNZC/AC/MC	44
CMLAEC3250EUZ/A/M	52	CMNN2525Z	149	CMPN03Z/A	175	CMPNZD/AD/MD	44

CMPNZE/AE/ME	44	CMRV352420Z	58	CMX100/AL/M	34	CMXC50Z/A/M	36
CMPNZF/AF/MF	44	CMRV3550	58	CMX10HDZ/A/M	35	CMXC60Z/A/M	36
CMPNZG/AG/MG	44	CMRV402620Z	58	CMX11/AL/M	32	CMXC70Z/A/M	36
CMPNZH/AH/MG	44	CMSC1645Z	150	CMX110/A/M	34	CMXM20Z/A/M	33
CMPO029Z/A/M	68	CMSC1663PZ	150	CMX115Z/A/M	34	CMY150CRKITA/M	138
CMPOA/CMPOWA	176	CMSC1763Z	150	CMX11HDZ/A/M	35	CMY150KITA/M	138
CMPOWZ/A/M	67	CMSH090Z	74	CMX12/AL/M	32	CMY200250KITA/M	139
CMPOZ/CMPOWZ	176	CMSH091Z	74	CMX120Z/A/M	34	CMY300350KITZ/A/M	139
CMPPA/CMPPWA	176	CMSH125Z	74	CMX123Z/A/M	34	CMY300350XPKITZ/A/M	139
CMPPWZ/A/M	67	CMSH126Z	74	CMX125Z/A/M	34	CMY4050KITZ/A/M	139
CMPPZ/CMPPWZ	176	CMSH127Z	74	CMX12HDZ/A/M	35	CMY4060KITZ/A/M	139
CMR01/AL/M	40	CMSH505Z/A/M	71	CMX13/AL/M	32	CMY6090KITZ/A/M	140
CMR02/AL/M	40	CMSH514	71	CMX13HDZ/A/M	35	CMY80100KITZ/A/M	140
CMR03/AL/M	40	CMSH579Z	59	CMX14/A/M	32	CMYHP200300KITA/M	139
CMR037536Z	178	CMSH587Z	59	CMX15/AL/M	32	CMZ01BSZ/A/M	168
CMR04/AL/M	40	CMSH649Z	59	CMX16HDZ/A/M	35	CMZ02Z/A	168
CMR05/AL/M	40	CMSH650Z	59	CMX17/AL/M	32	CMZ03B/A/Z/GA/GZ/AA/AZ	166
CMR0512Z	178	CMSH651Z	59	CMX17HDZ/A/M	35	CMZ03BZ/A/AA	166
CMR0536Z	178	CMSH732Z/A/M	59	CMX18/AL/M	32	CMZ03SA/SM/SZ/AA/AM/AZ	...
CMR062512Z	178	CMSTRGERKITZ/A/M	84	CMX18HDZ/A/M	35	... /GA/GZ	166
CMR062539Z	178	CMSXAKITZ/A/M	125	CMX19/AL/M	32	CMZ04SA/SM/SZ/AA/AM/AZ	...
CMR07/AL/M	40	CMSXKITZ/A/M	125	CMX1L7HDZ/A/M	35	... /GM/GZ	163
CMR07512Z	178	CMSZ150350KITZ/A/M	116	CMX20/AL/M	32	CMZ06SA/SM/SZ/AA/AM/AZ	...
CMR07539Z	178	CMSZ1Z/A/M	142	CMX21/AL/M	33	... /GM/GZ	161
CMR087539Z	178	CMSZ4050KITZ/A/M	116	CMX22Z/AL/M	33	CMZ10Z/A/M	65
CMR12539Z	178	CMSZ90140KITZ/A/M	116	CMX25/AL/M	33	CMZ12SA/AZ	157
CMR139Z	178	CMT20/A/M	69, 157	CMX28/AL/M	33	CMZ13AZ/SA	158
CMR1524Z	178	CMT21/A/M	69, 158	CMX30/AL/M	33	CMZ14AZ/SA/AA	161
CMR224Z	178	CMTYPE3Z/A	173	CMX34/AL/M	33	CMZ15BZ/A	167
CMR324Z	178	CMV15/A/M	116	CMX35/AL/M	33	CMZ19SZ/A	168
CMRE16Z/A/M	111	CMV16/A/M	116	CMX40/AL/M	33	CMZ22Z/A/M/AA/AM/AZ	...
CMRE20Z/A/M	111	CMV17/A/M	117	CMX45/AL/M	33	... /GM	169
CMRE28Z/A/M	111	CMV18/A/M	117	CMX453Z/A/M	179	CMZ24BSZ/A	168
CMRE50Z/A/M	111	CMVERADO4KITA/M	103	CMX473Z/A/M	179	CMZ24BSZ/A/M	69
CMRF104Z/A/M	71	CMVERADO6KITA/M	103	CMX50/AL/M	33	CMZ26SZ/A/AA/GZ/SZ	169
CMRF484Z	73	CMVM20PZ	151	CMX55/AL/M	33	CMZC5SA/SZ/AA/AZ	163
CMRG20Z/A/M	57	CMVM20Z	151	CMX58Z/A/M	179	CMZC7SA/SZ/AA	164
CMRG25Z/A/M	57	CMVM40PZ	151	CMX60/A/M	33	CMZCT2WZ/A	174
CMRG30Z/A/M	57	CMVM40Z	151	CMX65/A/M	34	CMZD56/A/M	158
CMRG35Z/A/M	57	CMVMBP10	151	CMX70/A/M	34	CMZD58/A	162
CMRG40Z/A/M	57	CMVMBP8	151	CMX75/A/M	34	CMZD72BM/MM/MA	167
CMRG45Z/A/M	57	CMVMM10PZ	151	CMX80/A/M	34	CMZD72BZ	169
CMRG50Z/A/M	57	CMVMM10Z	151	CMX85/A/M/	34	CMZD77EURO/A/M	163
CMRG55Z/A/M	57	CMVP16520Z	151	CMX90/A/M	34	CMZD78B/A	165
CMRG60Z/A/M	57	CMVPIPSKITZ/A/M	126	CMX95Z/A/M	34	CMZH054Z	73
CMRP4Z/A/M	74	CMX00/A/M	31	CMXC01Z/A/M	35	CMZH058NZ	68
CMRP5Z/A/M	74	CMX01/AL/M	31	CMXC02Z/A/M	35	CMZH058Z	68
CMRP6SZ/A/M	74	CMX018125/AL	31	CMXC03Z/A/M	35	CMZH470Z	68
CMRP6Z/A/M	74	CMX02/AL/M	31	CMXC04Z/A/M	35	CMZH479Z/A/M	70
CMRP7Z/A/M	74	CMX03/AL/M	31	CMXC05Z/A/M	35	CMZH480Z/A/M	71
CMRP8Z/A/M	74	CMX04/AL/M	31	CMXC06Z/A/M	36	CMZH494Z/A/M	70
CMRP9Z/A/M	74	CMX05/AL/M	31	CMXC07Z/A/M	36	CMZH504Z	70
CMRV221615Z	58	CMX05A/AL/M	31	CMXC08Z/A/M	36	CMZHC06GBZ/A	164
CMRV221620Z	58	CMX0625	31	CMXC09Z/A/M	36	CMZHC2AZ/AA/AM	159
CMRV2230	58	CMX07/AL/M	31	CMXC25Z/A/M	36	CMZHC2Z/A/M	69
CMRV251815Z/A/M	58	CMX08/AL/M	31	CMXC30Z/A/M	36	CMZHC3AZ/A/M	159
CMRV2518175Z/A/M	58	CMX09/AL/M	31	CMXC35Z/A/M	36	CMZHC47SA/CMAHC20SBS/	...
CMRV251820Z	58	CMX09HDZ/A/M	35	CMXC40Z/A/M	36	CMZHC47SZ/CMZHC42SBS	170
CMRV302015Z	58	CMX10/AL/M	32	CMXC45Z/A/M	36	CMZHC5AZ/A/M	69, 162

CMZHS47SA/CMMAHS20S/		JDH54GBZ/A	191	JDZD170GZ/A	190
CMZHS47SZ/CMZHS42S	171	JDH55GBZ/A	184	JDZT8GZ/A	196
CMZL18BGZ/A/M	167	JDH56GBZ/A	184	SGAO072Z/A/M	71
CMZSC12Z/A/M	164	JDH58GBZ/A	191	SGBA001Z/A/M	75
CMZTSA/SZ/AA/AZ/GA/GZ	163	JDH59GBZ/A	192	SGBA506Z/A/M	75
JD237Z/A	197	JDH5GZ/A	190	SGBA597Z/A/M	75
JD485GZ/A	194	JDH60GZ/A	189	SGFF652Z/A/M	48
JDB2GBZ/A	181	JDH61GBZ/A	186	SGFL501Z/A/M	70
JDB3GBZ/A	183	JDH62GBZ/A	183	SGPL355Z/A/M	72
JDB4GBZ/A	184	JDH63GBZ/A	186	SGPL356Z/A/M	71
JDB8GBZ/A	185	JDH6GZ/A	189	SGPL572Z/A/M	72
JDB9GBZ/A	187	JDH7GZ/A	187	SGPL573Z/A/M	72, 91
JDC1GZ/A	194	JDI13GZ/A	196	SGPL576Z/A/M	71
JDDM105GZ/A	193	JDI17GZ/A	197	SGSH100Z/A/M	195
JDDM121GBZ/A	189	JDMA3305SZ/A	192	SGSH101Z/A/M	195
JDDM121GZ/A	189	JDP320219Z	182	SGSH159Z/A/M	195
JDDM155Z/A	190	JDP320220Z	181	SGSH16Z/A/M	72, 195
JDDM20Z/A	182	JDP320221Z	181	SGSH25Z/A/M	72, 195
JDDM217Z/A	192	JDP320222Z/A	181	SGSH506Z/A/M	195
JDDM28GBZ/A	183	JDP320223Z	181	SGSH507Z/A/M	195
JDDM45Z/A	185	JDP320224Z	183	SGSH508Z/A/M	195
JDDM60GZ/A	186	JDROD100DZ	199	SGSH509Z/A/M	195
JDDM96GZ/A	187	JDROD100Z/A	200	SGSH510Z/A/M	195
JDE2GZ/A	193	JDROD105Z/A	200	SGSP71180Z/A/M	123
JDE3GZ/A	194	JDROD110Z/A	200	SGVT070Z/A/M	72
JDGBZH01Z/A	190	JDROD115Z/A	200	SGVT240Z/A/M	72
JDGBZH02Z/A	185	JDROD25DZ	198	SGVT507Z/A/M	72
JDGBZT01Z/A	196	JDROD25Z/A	199	SGVT695Z/A/M	72
JDH01Z/A	187	JDROD30Z/A	199	STE217841Z	151
JDH10GZ/A	184	JDROD40Z/A	199	TYPE1	175
JDH11GZ	190	JDROD45Z/A	199	TYPE2	175
JDH13GBZ/A	188	JDROD50Z/A	199	WASHRAD100C	54
JDH15GZ/A	191	JDROD55Z/A	199	WASHRAD2225C	54
JDH17GZ/A	192	JDROD60Z/A	199	WASHRAD30C	54
JDH21GBZ/A	188	JDROD65Z/A	199	WASHRAD35C	54
JDH22GBZ/A	193	JDROD69DZ	199	WASHRAD40C	54
JDH22GZ/A	193	JDROD70Z/A	199	WASHRAD45C	54
JDH23BZ/A	190	JDROD75Z/A	199	WASHRAD50C	54
JDH24GBZ/A	193	JDROD80Z/A	199	WASHRAD55C	54
JDH24GZ/A	182	JDROD85Z/A	199	WASHRAD60C	54
JDH25SZ/A	191	JDROD90Z/A	199		
JDH26GZ/A	188	JDROD95Z/A	200		
JDH27GZ/A	194	JDS4GZ/A	184		
JDH34GZ/A	193	JDS8GZ/A	186		
JDH35GZ/A	191	JDS9EGZ/A	188		
JDH36GA	188	JDS9GZ/A	187		
JDH37SZ/A	191	JDT11GZ/A	197		
JDH39SBZ/A	182	JDT12GZ/A	196		
JDH3GZ/A	194	JDT13GZ/A	196		
JDH40SBZ/A	192	JDT14GZ/A	197		
JDH45GBZ/A	189	JDT14GZF/AF	198		
JDH47GBZ/A	187	JDT15GZ/A	198		
JDH48GZ/A	182	JDT16GZ/A	198		
JDH49GBZ/A	183	JDT19GZ/A	198		
JDH4GZ/A	192	JDT1GZ/A	197		
JDH50GBZ/A	185	JDT22GZ/A	198		
JDH51GZ/A	186	JDT3GZ/A	197		
JDH52GZ/A	188	JDT9GZ/A	196		
JDH53GBZ/A	185	JDZD140GZ/A	189		



CMP doubles down on non-toxic anodes

IN A BID TO DOMINATE THE GLOBAL ANODE MARKET, CANADA METAL (PACIFIC) IS INVESTING HEAVILY IN ITS NON-TOXIC PRODUCT LINE, POSITIONING ITSELF TO COMPETE SIMULTANEOUSLY ON QUALITY AND PRICE.

WORDS: CRAIG RITCHIE

They may not be the most glamorous components to be found in a marine equipment store, but sacrificial anodes nonetheless perform one of the most important jobs on the water, by protecting expensive metal components from corrosion. To that end, there isn't a parts counter anywhere that doesn't sell them.

Traditionally, sacrificial anodes have been made from zinc – to the point where they have become universally known as “zincs” rather than by their proper name. In the face of growing environmental sensitivity among consumers worldwide, Delta, British Columbia-based anode manufacturer Canada Metal (Pacific), or CMP, has elected to focus its Martyr anode business on non-toxic alternatives to zinc – alternatives that not only exceed the original material's performance while alleviating

ecological concerns, but have come to cost less than the original product, providing greater margins for distributors and dealers alike.

THE PROBLEM WITH ZINC

Zinc anodes have been used for decades as the primary means of protecting metal components like drive shafts and lower units from galvanic corrosion in both freshwater and saltwater environments. “In a nutshell, anodes protect the metal surfaces they are attached to by being constructed from materials with a more active electro-chemical voltage range,” explains Michael Szwed, director of marketing/general counsel at Canada Metal (Pacific). “They shift the focus of electro-chemical reactions which result in corrosion onto themselves, and away from the structures that they protect. It's a simple approach that works equally well on small boats, large yachts, commercial ships and



◀ CMP is introducing all-new branding and packaging for its anode lines, better identifying the premium products so consumers can understand the differentiation at a glance

CANADA METAL AT-A-GLANCE

- Location:** Delta, Canada; Woodbridge, Canada; Ningbo, China; Virginia, USA; Casella, Italy
- Early 1900s:** Foundry operations established by Carrasco and NL Industries to serve plumbing and laundry industries
- 1987:** Acquired from Carrasco, expanded focus on marine
- 1991:** Acquisition of 50% of Pacific Die Casting
- 1993:** Full acquisition of Pacific Die Casting, incorporated as Canada Metal (Pacific) Ltd
- 1999:** Acquisition of Ortopus autjeljelo
- 2004:** Establishment of foundry operations in Ningbo, China
- 2010:** Launch of Titan Marine Division
- 2011:** Acquisition of Selvaqua Italiana S.p.A., acquisition of Rocha and Vulcan Anchor lines
- 2014:** Establishment of CMP Global Limited
- 2015:** Buys controlling interest in Dock Edge Plus

shoreline installations like docks and lock gates.”

While zinc is an effective anode material, and small amounts of zinc are essential for human health, in higher concentrations the element has been found to be highly toxic to plants, invertebrates and fish. Worst still, zinc anodes typically include some amount of cadmium, which has been associated with serious illnesses including kidney disease, atherosclerosis, hypertension and cardiovascular diseases. Further, there is growing concern that exposure to cadmium may be linked to immune system deficiencies, with recent studies revealing a significant correlation between cadmium exposure and the occurrence of disease in human populations.

Such findings have inevitably raised concerns about the continued use of zinc anodes in marine environments. In the United States, bans on the use of zinc anodes have been proposed in California and Maryland after studies identified high levels of the element in local environments located near large marinas.

The third strike against traditional zinc anodes is financial. The cost of zinc has increased substantially in recent years, rising from a level of approximately US\$0.70 per pound in December 2015 to approximately US\$1.44 per pound today. “Zinc costs have basically doubled,” says Szwed. “Beyond that it’s a heavy material, so warehousing is a pain and

the shipping costs are enormous. You could probably justify the expense if it was a premium product, but it isn’t. There are much better alternatives available.”

ZINC ALTERNATIVES

The anode category is an important segment for Canada Metal, representing approximately 30% of the company’s overall business. With ISO 9001:2008-certified anode manufacturing facilities in British Columbia, Canada; Virginia, USA; Casella, Italy; and Ningbo, China, Canada Metal claims to be the only manufacturer that produces products for all three anode markets (fresh water, brackish water and salt water). While zinc anodes – sold under the Martyr “Traditional” branding – still represent somewhere around 60% of the company’s overall anode business, CMP has begun to focus much more heavily on its Martyr Premium[®] aluminium product line.

Aluminium anodes are said to provide numerous advantages over zinc, starting with simply being far more effective. In use, they last up to 50% longer than zinc anodes of comparable size. Aluminium is also much lighter in weight than zinc, and completely non-toxic. Aluminium’s superiority to zinc as an anode material is overwhelming enough that it has completely displaced zinc as the choice of engine manufacturers worldwide. “All of our OEM customers put aluminium on their product,” says Szwed. ▶

“Zinc costs have basically doubled. Beyond that it’s a heavy material, so warehousing is a pain and shipping costs are enormous”

MICHAEL SZWEZ, MARKETING DIRECTOR
CANADA METAL (PACIFIC)

Aluminium doesn't erode anywhere near as fast as zinc does, so customers look at the anode and think it isn't working!

"Mercury, BRP, Honda, Suzuki, Yamaha, Volvo Penta – all of them. It's by far the most effective anode material there is."

Ironically, the greater life span of aluminium anodes has led to sales resistance. "Aluminium doesn't erode anywhere near as fast as zinc does, so customers look at the anode and think it isn't working!" notes Szwesz. "If anything, we haven't done a good job of communicating the fact that aluminium anodes simply last longer. So part of our new focus will be on doing a better job of communicating the benefits of using the premium product."

The company also needs to do a better job of teaching customers that not all aluminium anodes are the same, says CMP president John Mitchell. Aluminium is a highly recyclable material, and its reuse is openly encouraged by government and military clients such as the US Navy, one of the world's largest anode buyers. "The US military specifications encourage the use of recycled aluminium, but there is a huge difference between recycled material and scrap," says Mitchell. "It's one thing to repurpose high-grade alloy from sources like high voltage wires, and quite another to melt down low-grade scrap. It sounds unbelievable, but there are suppliers out there who buy old, used-up anodes from shipyards, melt them down, then sell them right back to the same shipyards they sourced them from. No one is any the wiser until the next haul-out, and that's when the finger-pointing starts. That's why we adhere to a strict ISO 9001 Quality Management System, and our alloys are chemically tested constantly so they're guaranteed to meet the latest US military specifications. Otherwise, without some sort of third-party quality certification, how do you know what you're getting?"

CMP applies the same quality focus to its magnesium anodes, which represent the top-of-the-line for boats used in freshwater environments. Magnesium offers an extremely active electro-

chemical voltage range, giving it a substantial protection edge that surpasses that of zinc and even aluminium. "Nothing beats magnesium," notes Szwesz. "We sell it as a premium product, but only for freshwater applications. We don't recommend magnesium in saltwater environments because it's too effective, to the point it corrodes and disappears in such a short time it could leave the hull completely unprotected. In saltwater it dissolves like an antacid tablet. But in freshwater, it's far and away the best you can get."

DOUBLING DOWN

Although the benefits of premium anodes over traditional zincs may be clear to OEM customers, Szwesz notes that Canada Metal's top priority is to proactively educate aftermarket distributors and end-users alike on the advantages of using non-toxic anodes. The company was an early adopter of aluminium as an alternative to traditional zinc anodes, but it has never aggressively promoted its non-toxic line. "We had our Martyr zinc anodes, then came the Martyr 2 aluminium product," says Szwesz. "But the name Martyr 2 doesn't mean anything to a consumer. Customers walk into a store and they ask for new zincs, and that's exactly what they get. We need to do a better job of letting people know that premium non-toxic anodes exist and that they represent greater value by doing a better job for the same price. And that's what we've begun to do. We're introducing all-new branding and packaging for our anode lines, and better identifying the premium products so consumers can understand the differentiation at a glance. We've also produced new planograms and sales aids to help both dealers and end-users better understand why and when they need to replace them."

While CMP's new anode strategy rolled out worldwide this winter, the company will initially place a focus on Europe, which it sees as a traditional anode market split among small manufacturers that have neither the technical capability nor the production capacity to compete with non-toxic alternatives of their own. "Europe currently represents one of the greatest opportunities for CMP to grow its global market share," says John Mitchell, who moved to Italy in September 2014 in order to personally spearhead sales efforts on the continent. "I am confident that our significant investment to replace the traditional zinc with our premium aluminium product will realise not only a monetary reward, but a significant ecological one. It's the right thing to do, and not just from a business perspective. Boaters have a strong interest in protecting clean water and marine ecosystems – our job is to simply show them how they can do that by switching to more effective products." 

